

ICONOGRAPHIC
ENCYCLOPÆDIA
OF
SCIENCE, LITERATURE, AND ART.

BY
J. G. HECK.

THE TEXT TRANSLATED AND EDITED

BY
SPENCER F. BAIRD, A. M., M. D.,
PROFESSOR OF NATURAL SCIENCES IN DICKINSON COLLEGE, CARLISLE, PA.

P L A T E S .

VOL. II.

CONTAINING THE ILLUSTRATIONS TO DIVISIONS V.—X.

V.—MILITARY SCIENCES.

VI.—NAVAL SCIENCES.


VII.—ARCHITECTURE.

VIII.—MYTHOLOGY.

IX.—FINE ARTS.

X.—TECHNOLOGY.

NEW YORK: 1851.
PUBLISHED BY RUDOLPH GARRIGUE,
2 BARCLAY STREET (ASTOR HOUSE).



ICONOGRAPHIC
E N C Y C L O P Æ D I A .

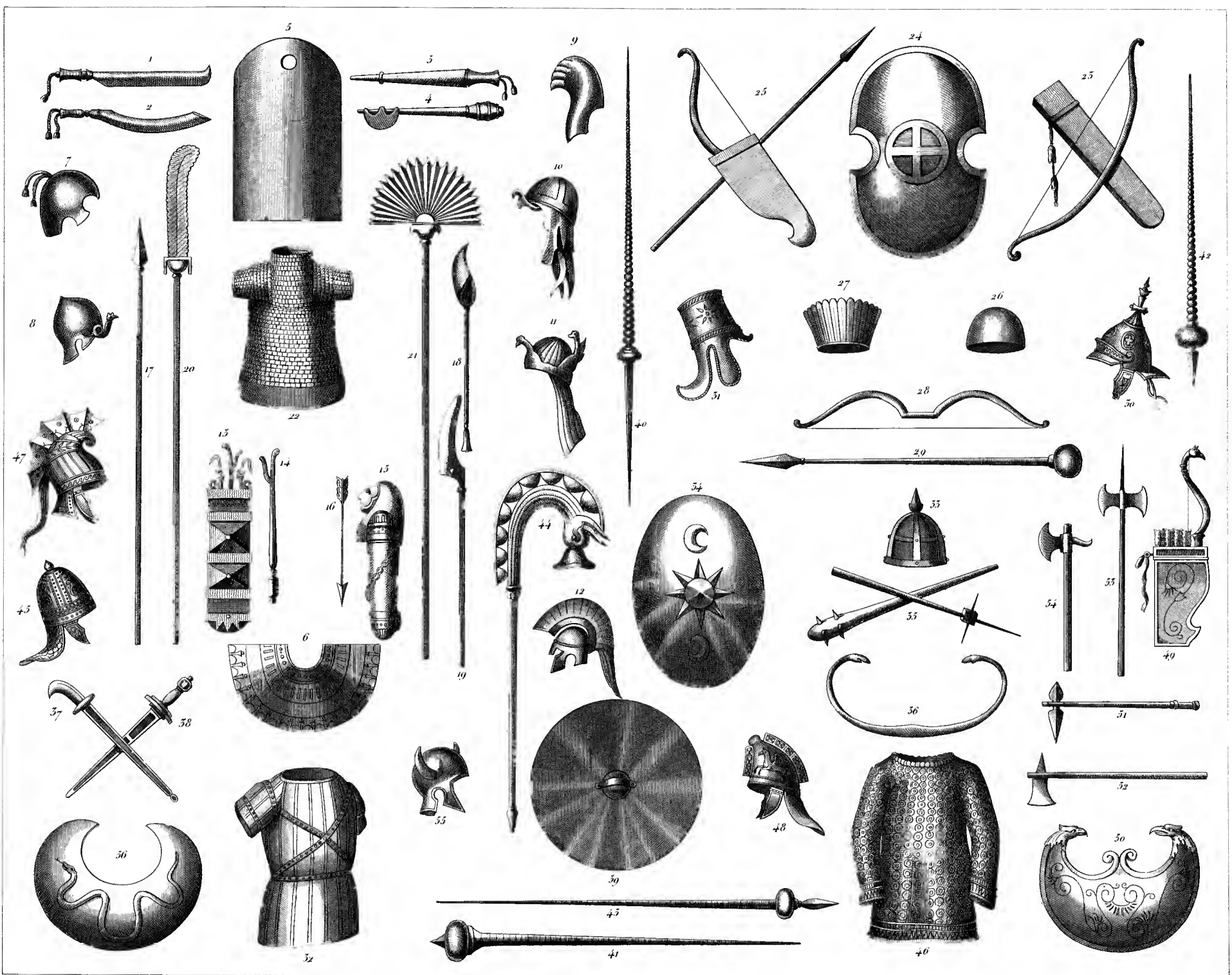
DIVISION V.

MILITARY SCIENCES.

FIFTY-ONE PLATES.

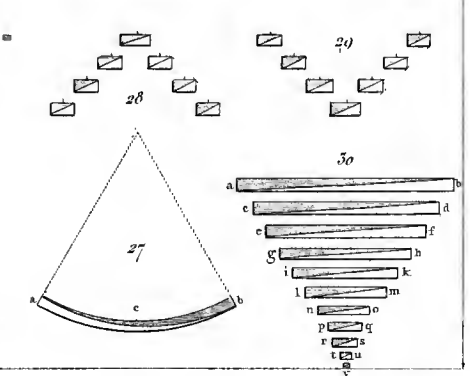
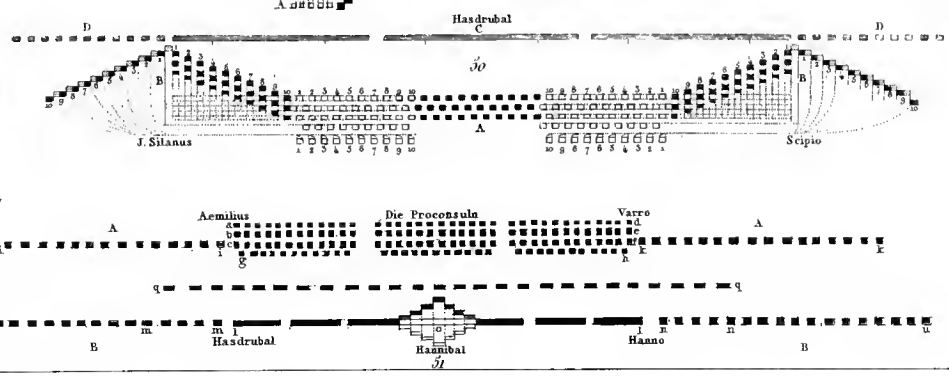
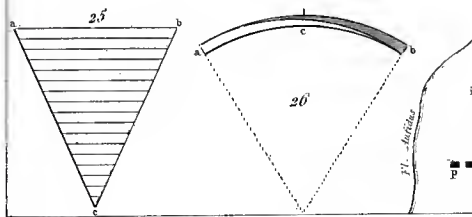
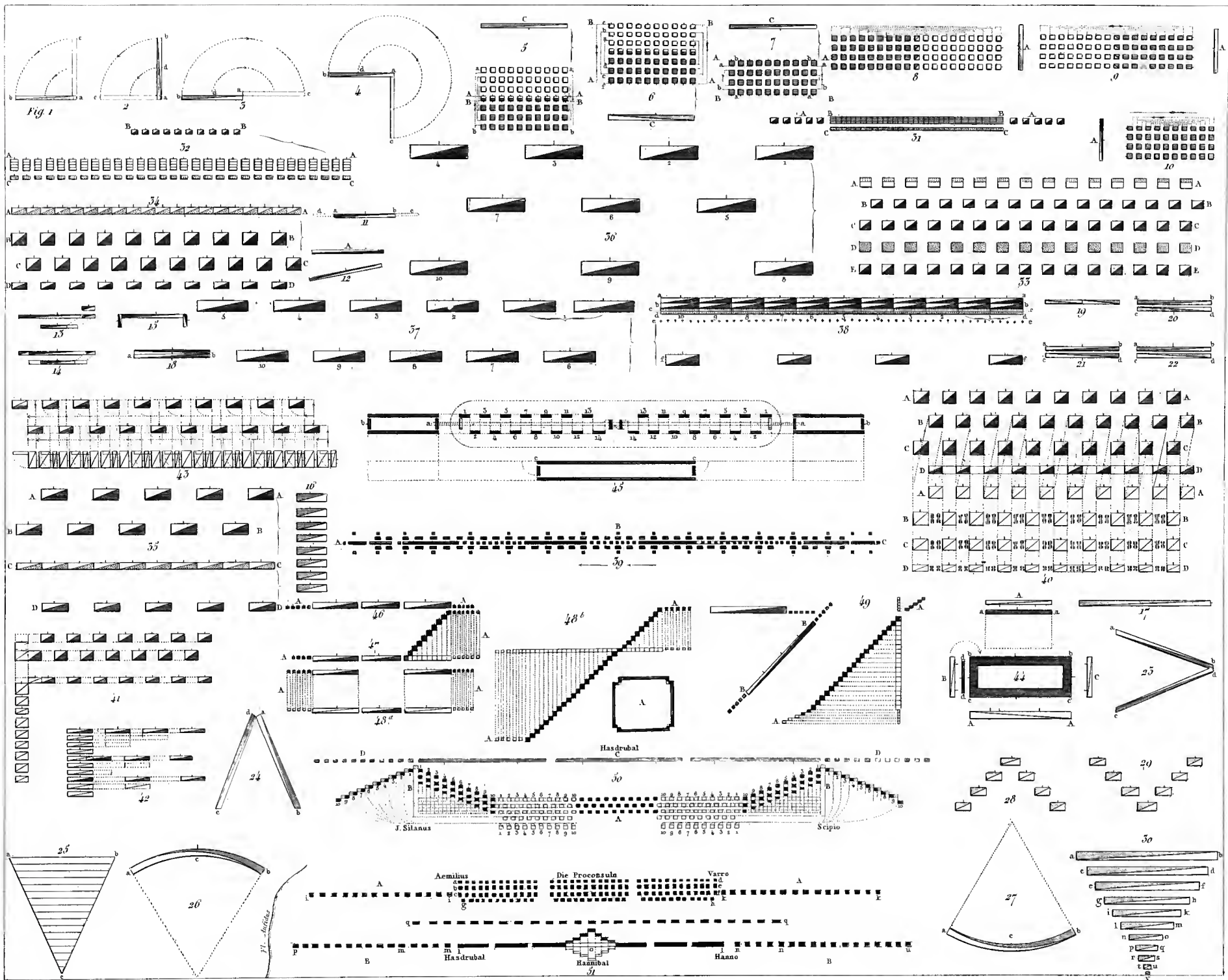
NEW YORK: 1851.
PUBLISHED BY RUDOLPH GARRIGUE,
2 BARCLAY STREET (ASTOR HOUSE).

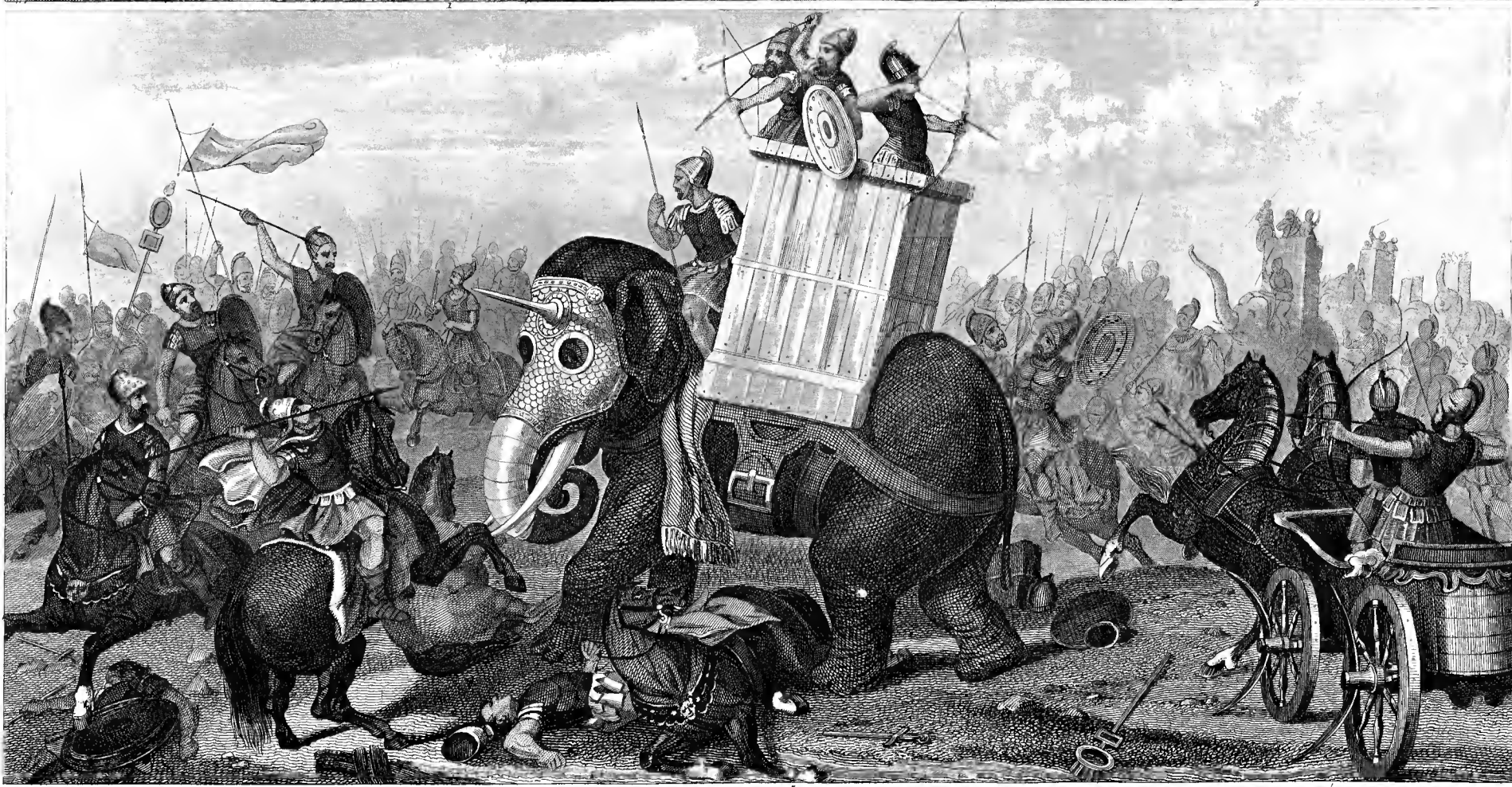
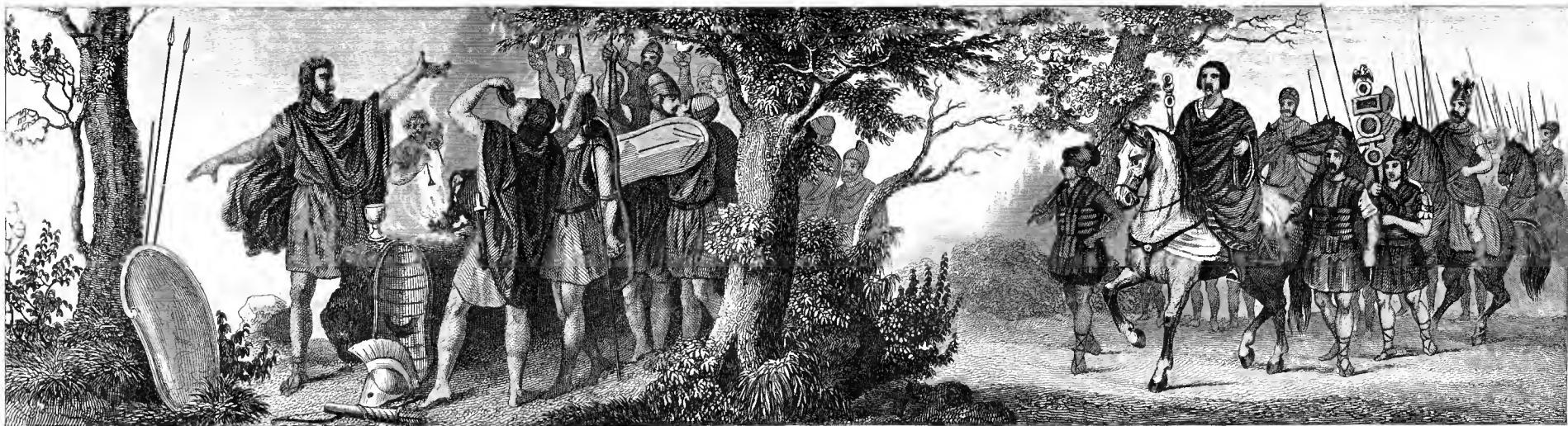


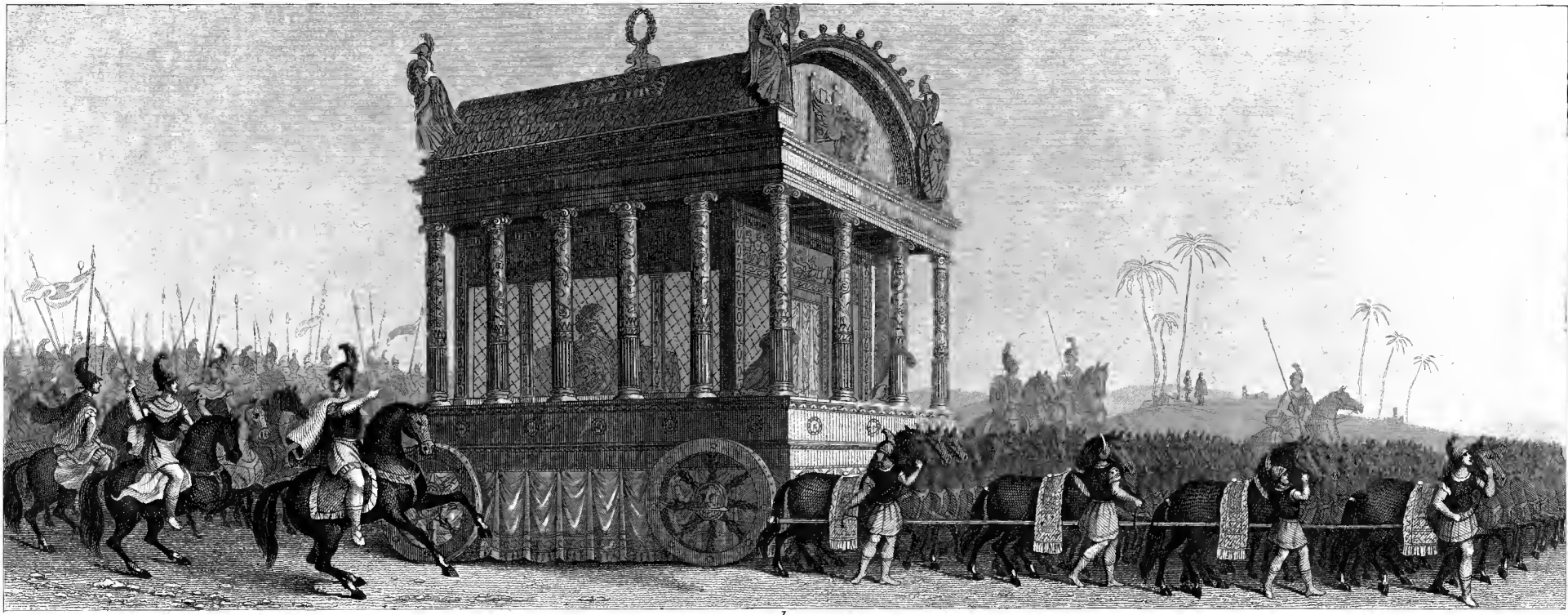










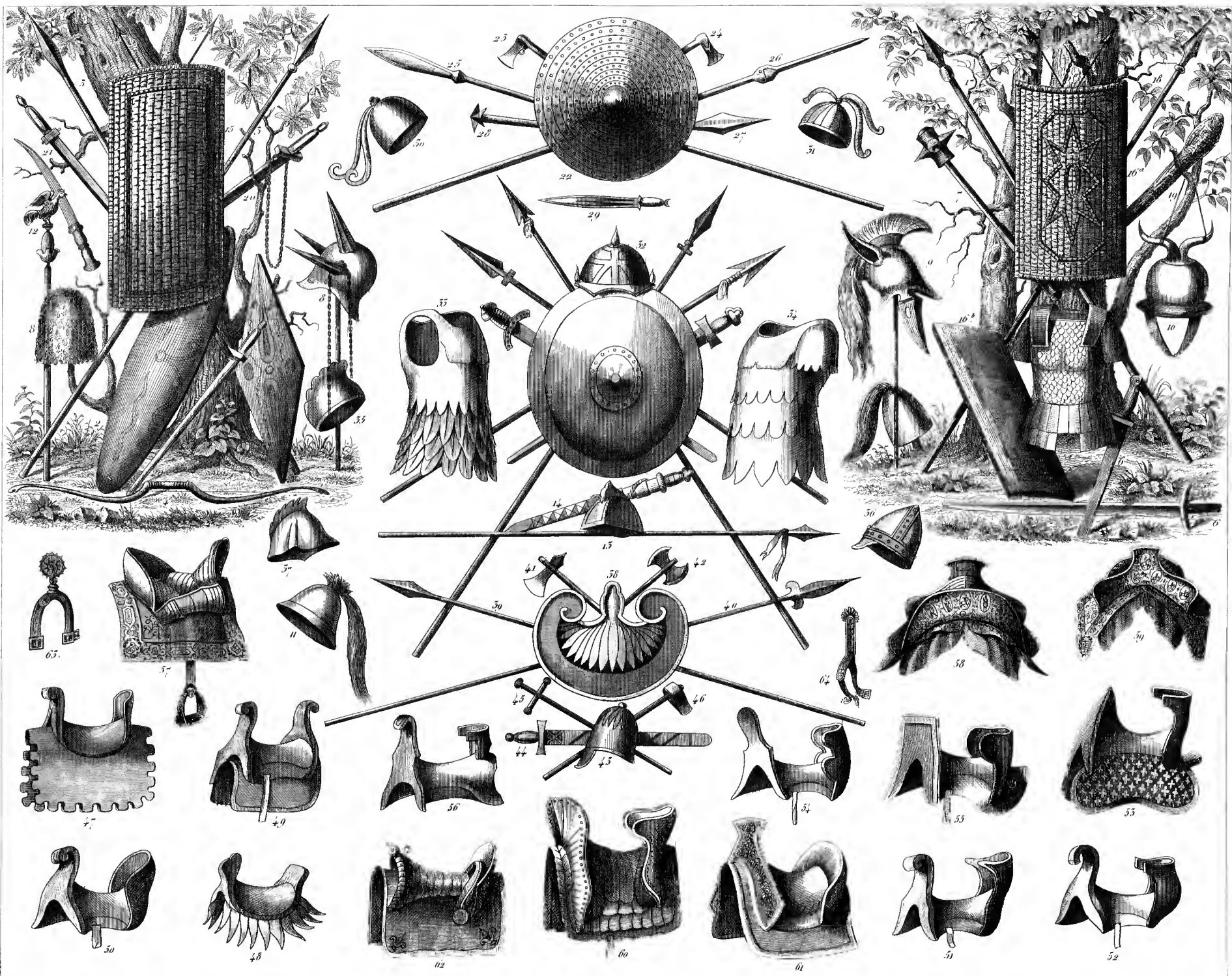


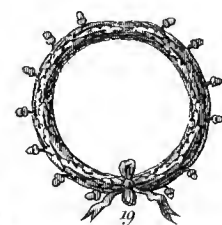
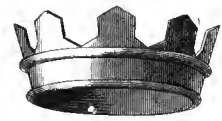
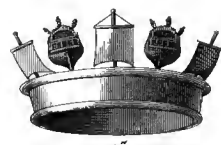
1



2







24

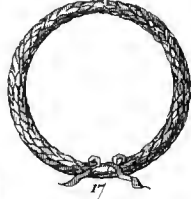
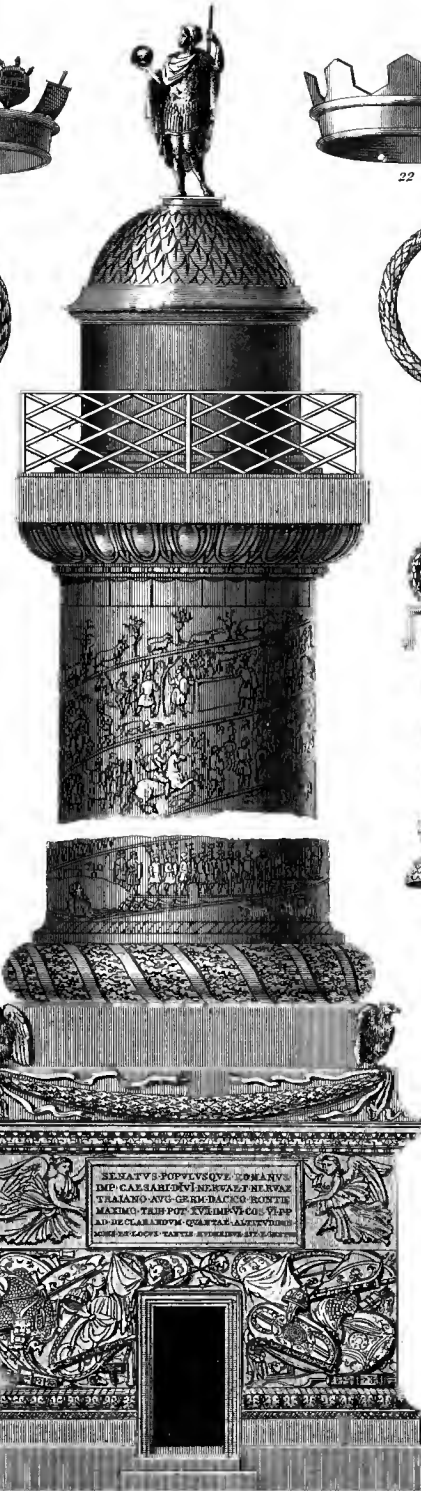
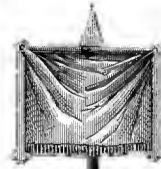
20

25

22

19

25



2

6

3

7

8

13

14



27

28

26

9

10

11

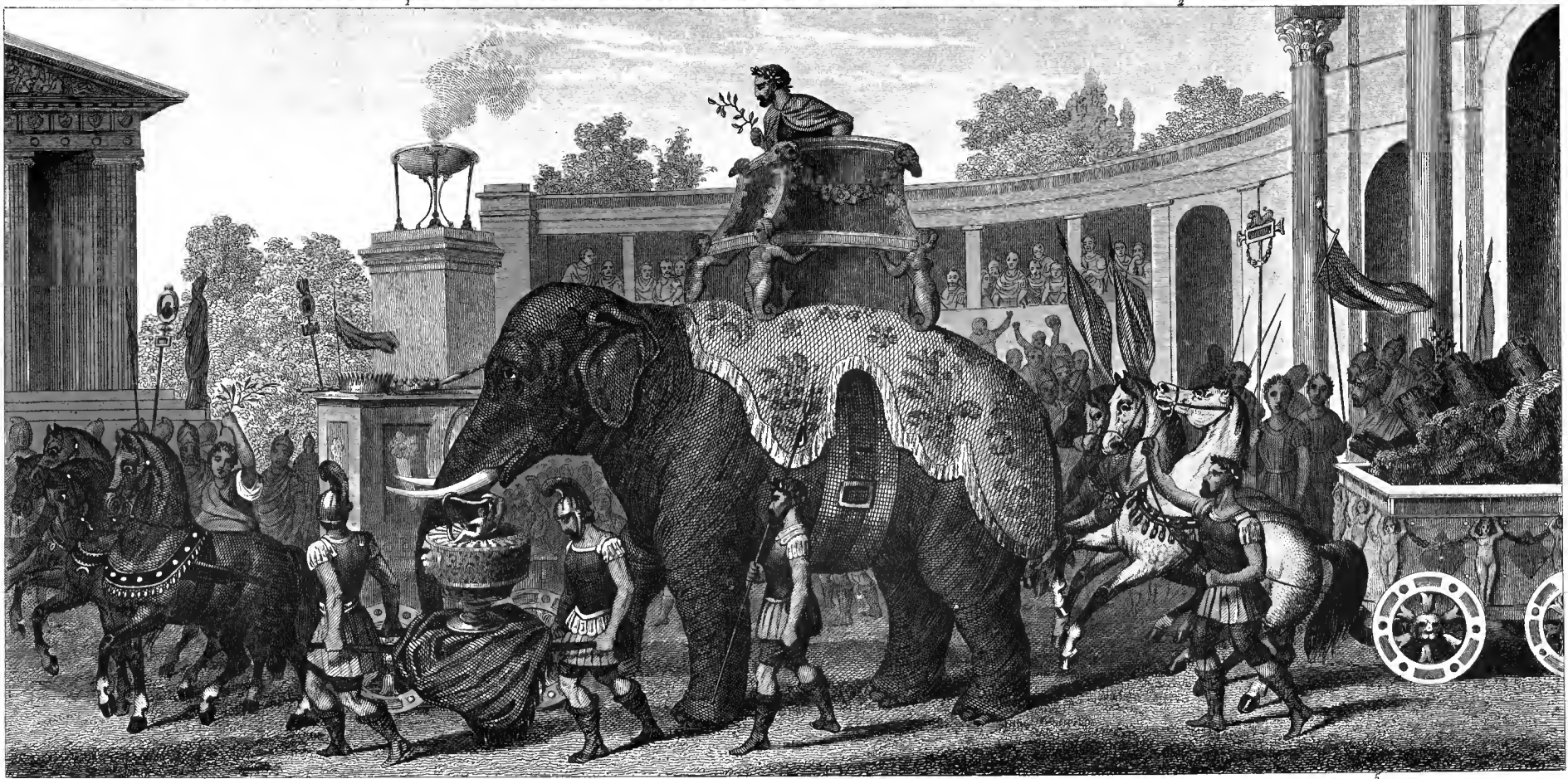
12

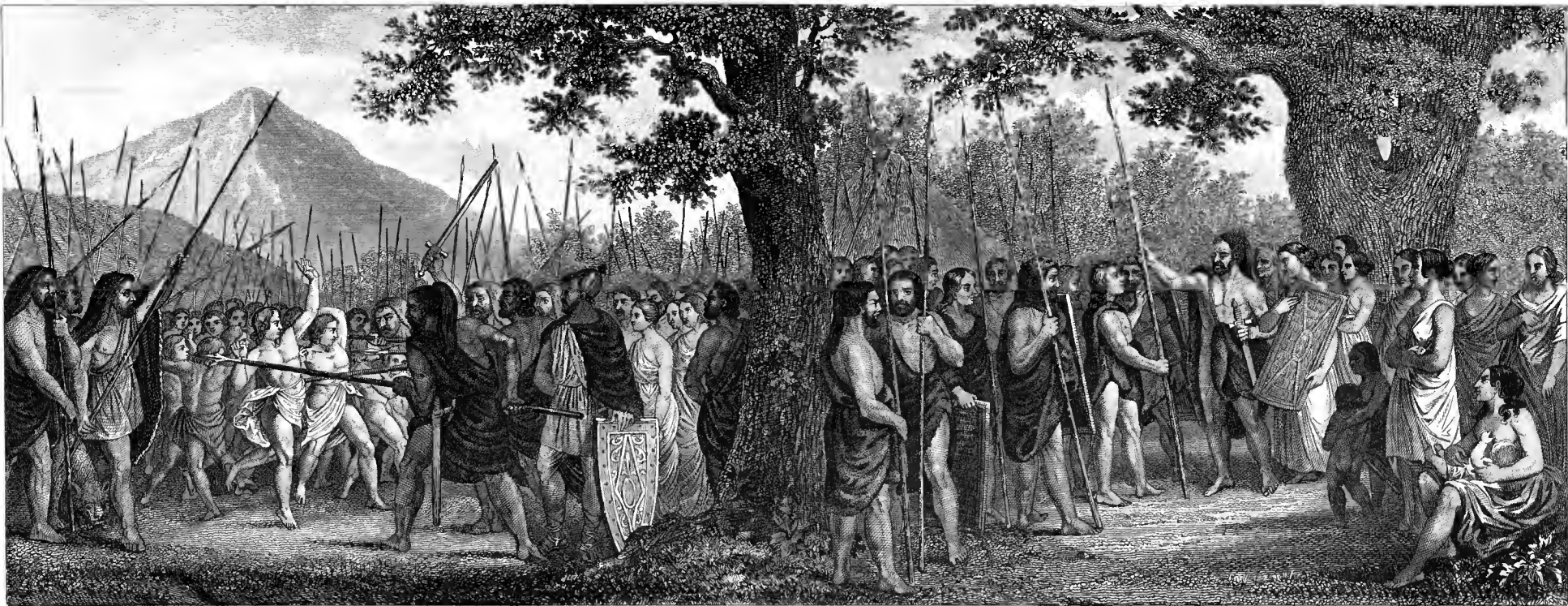
15

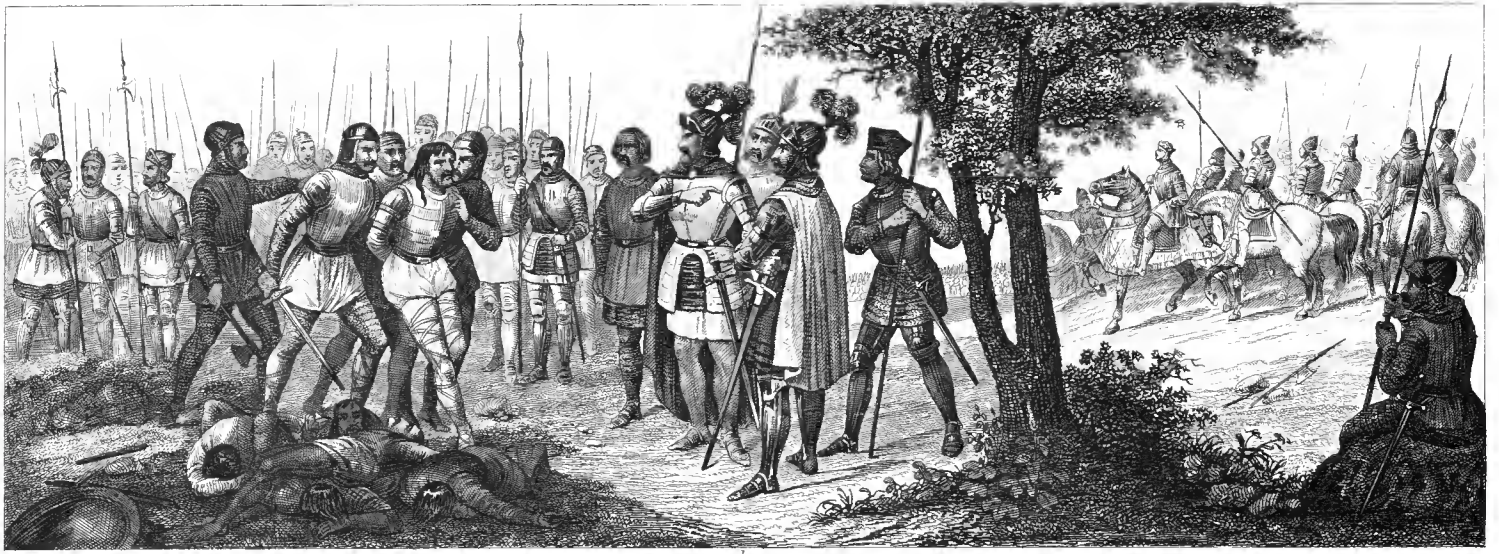
1

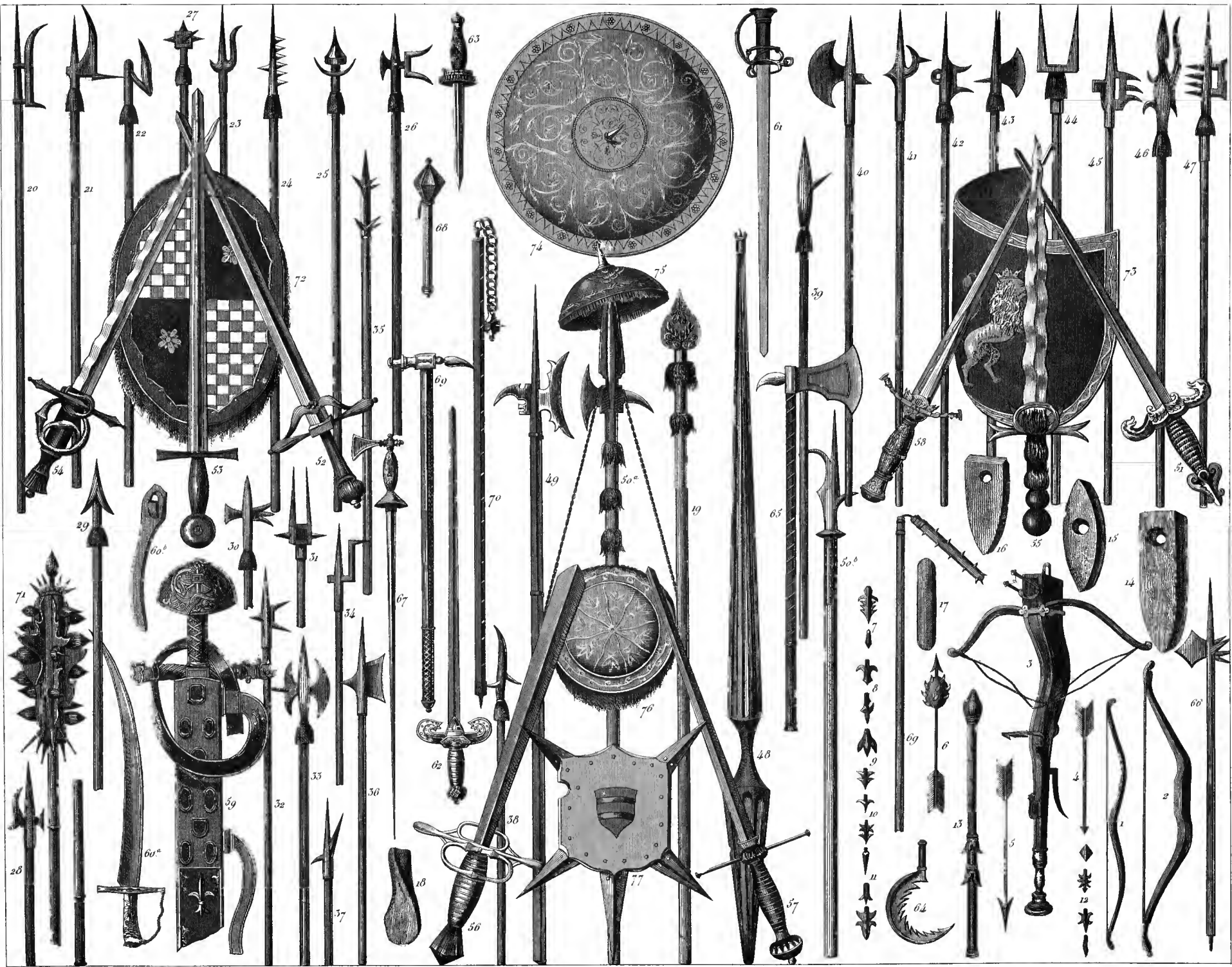
4

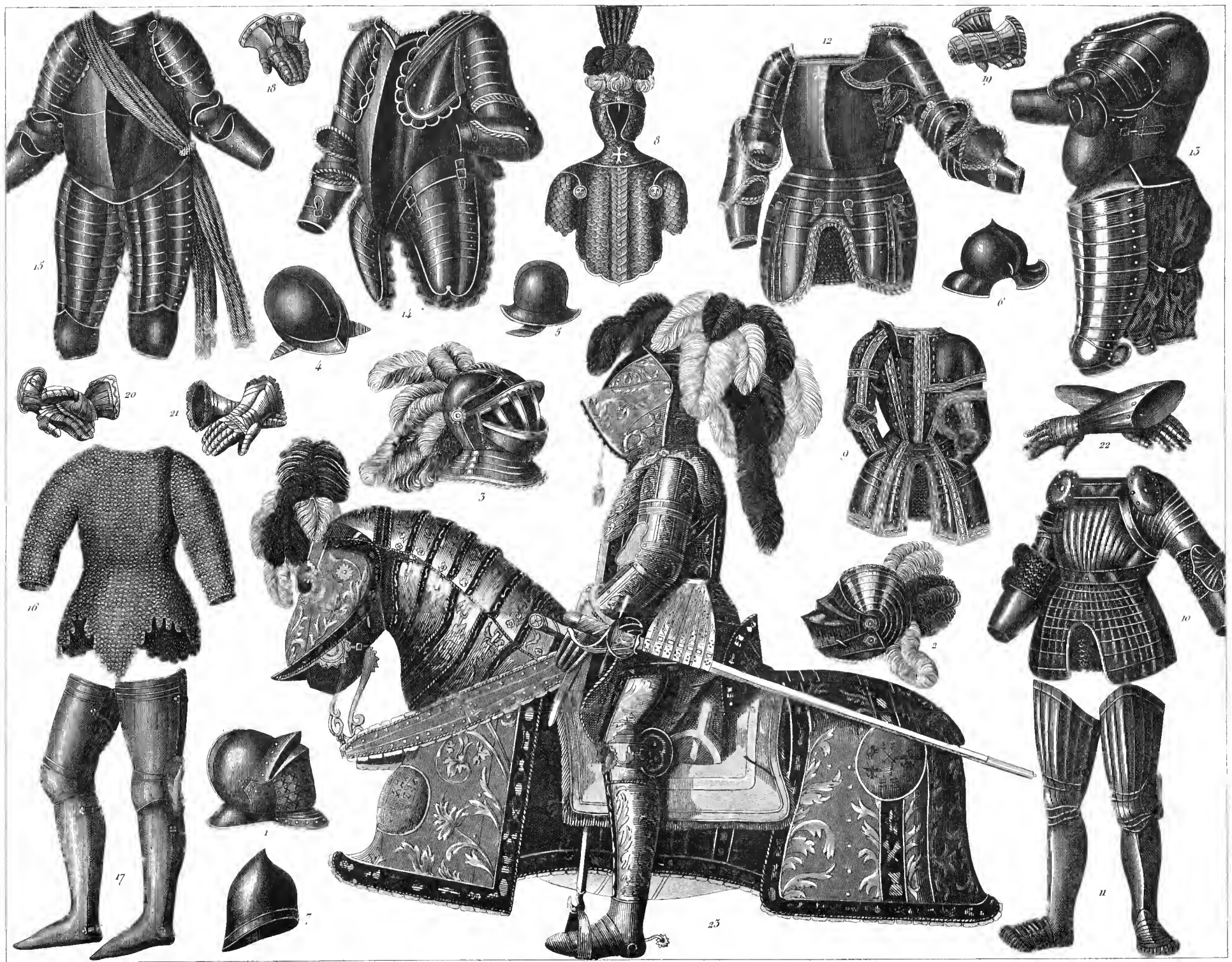
15













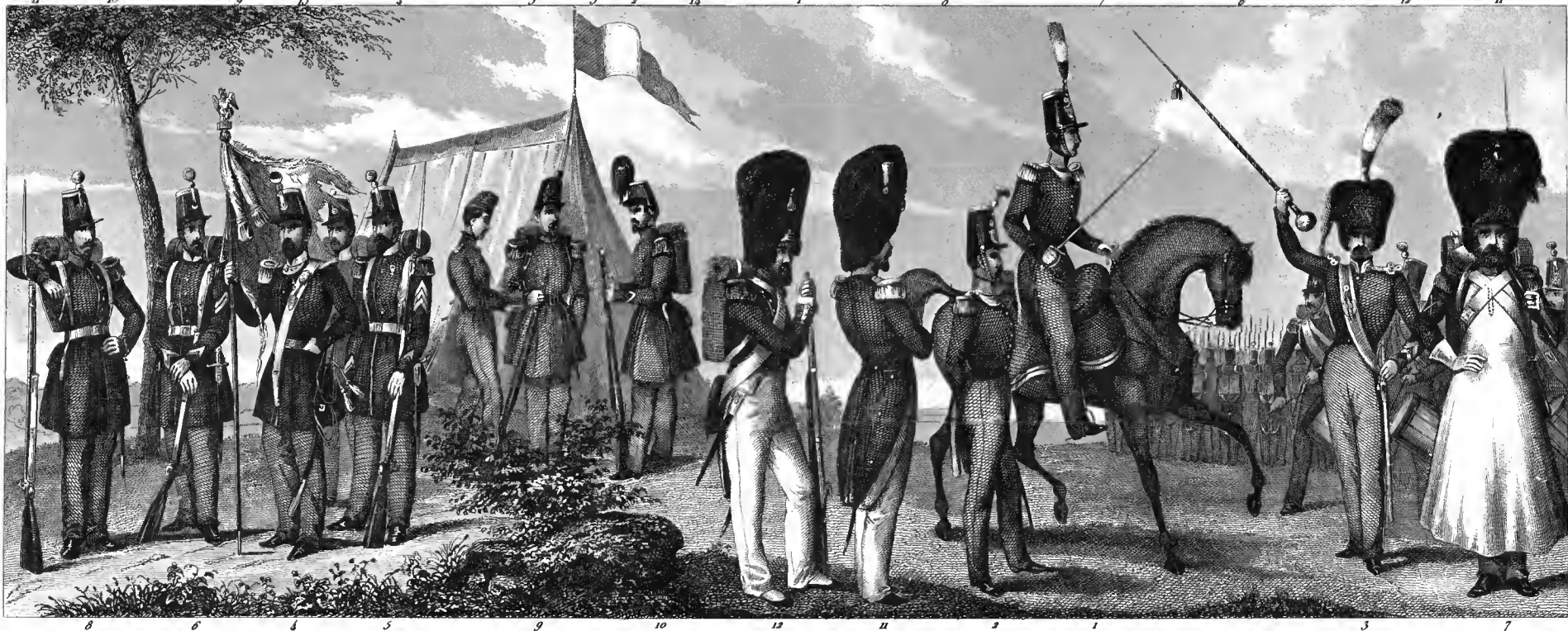
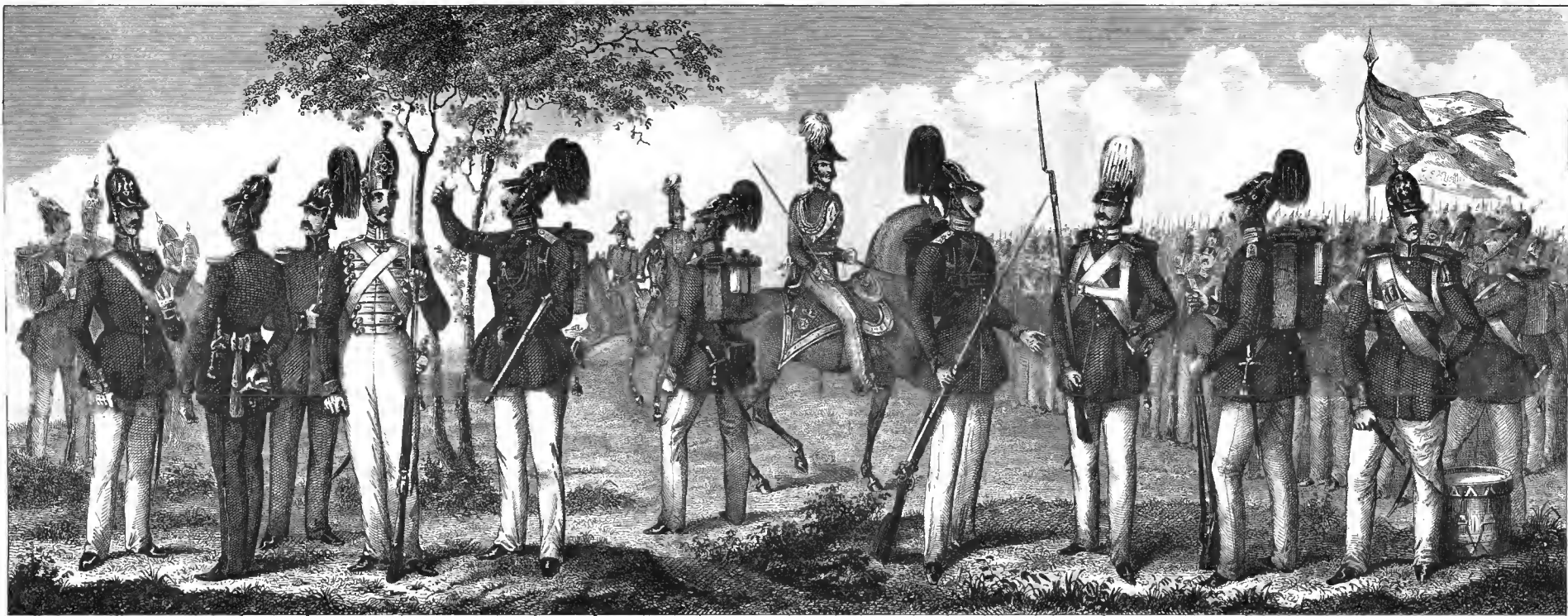


7

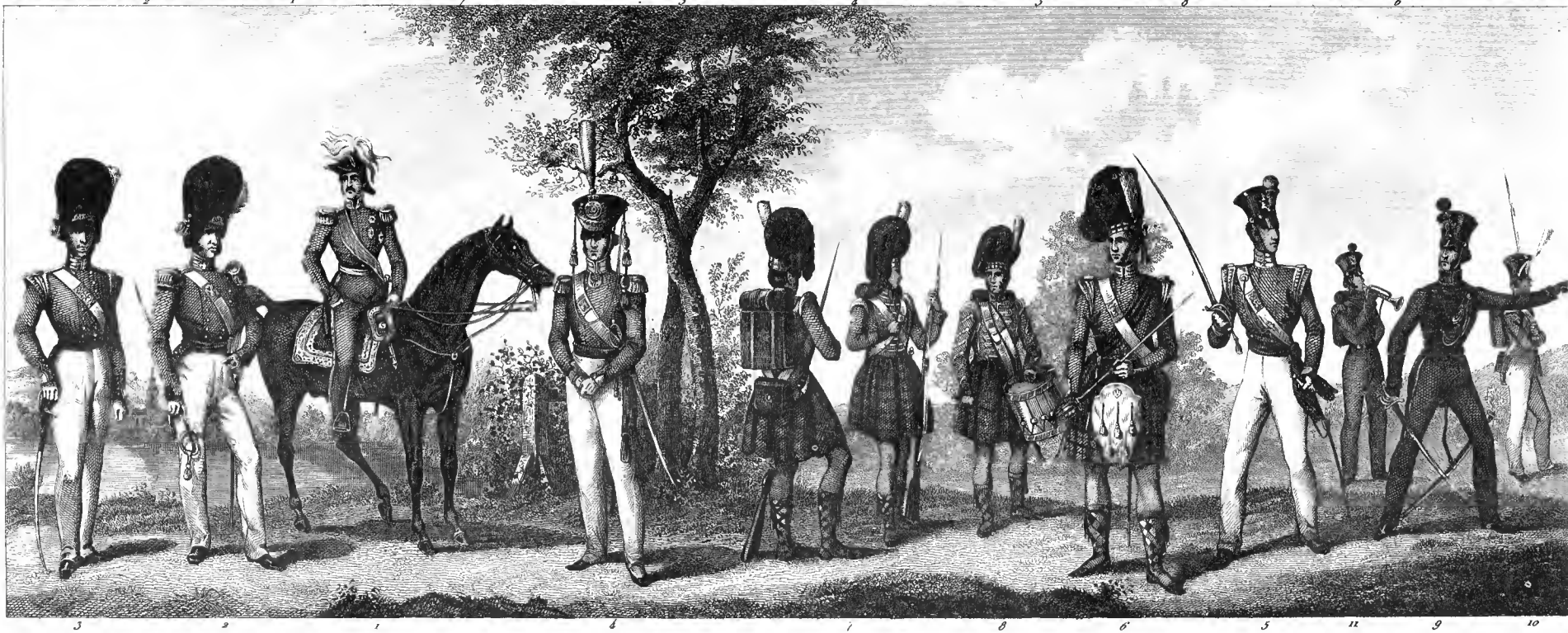
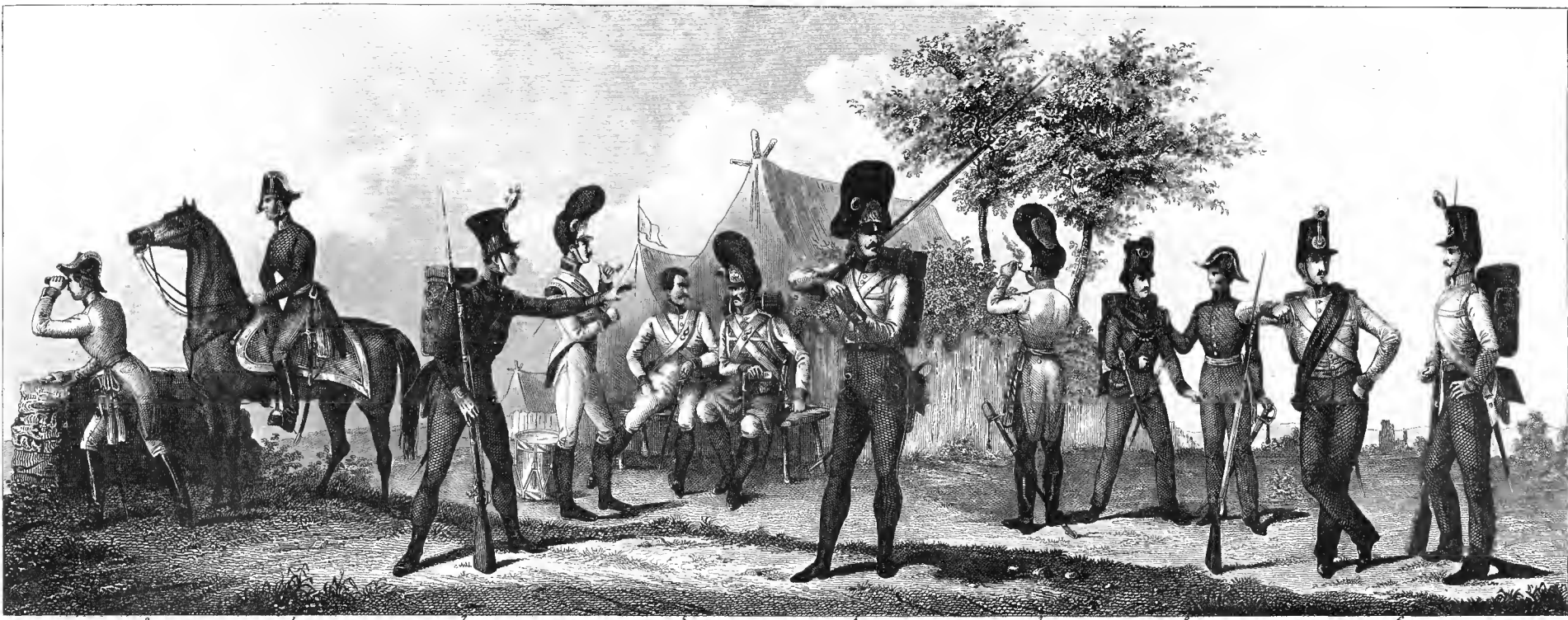
8

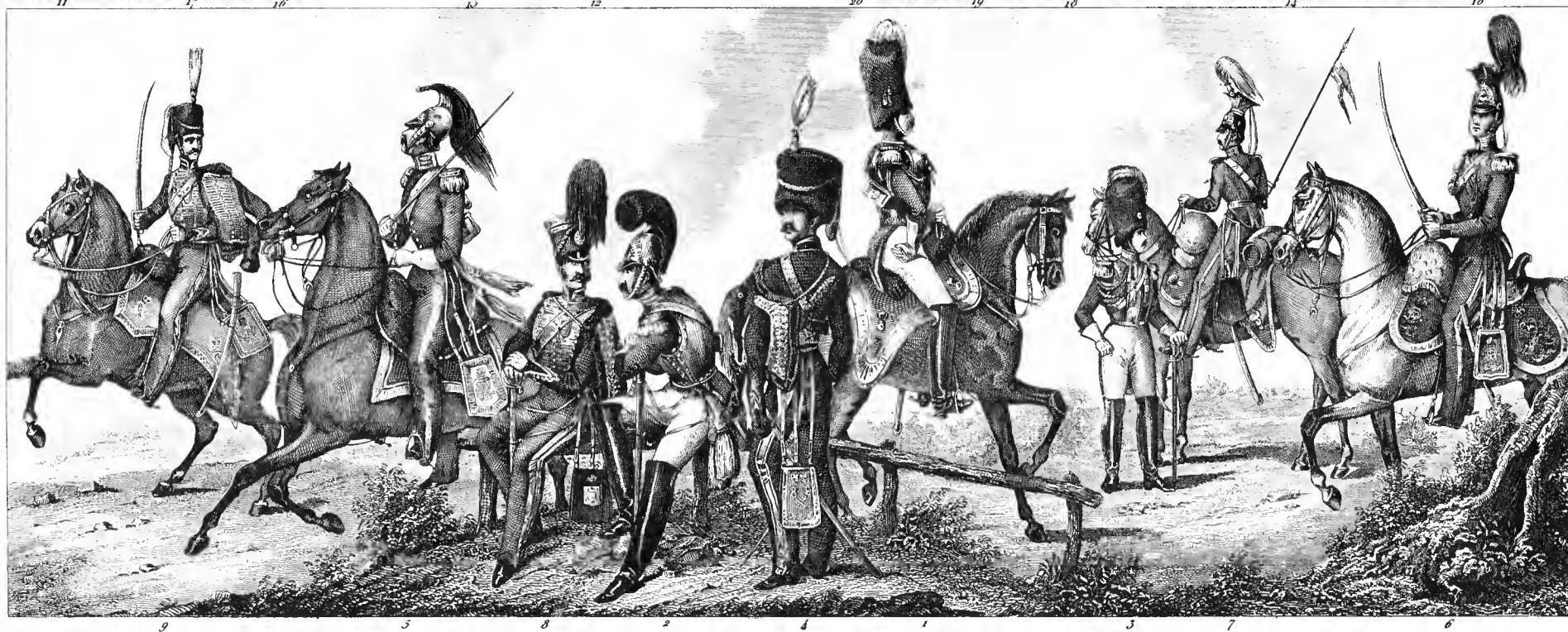
9

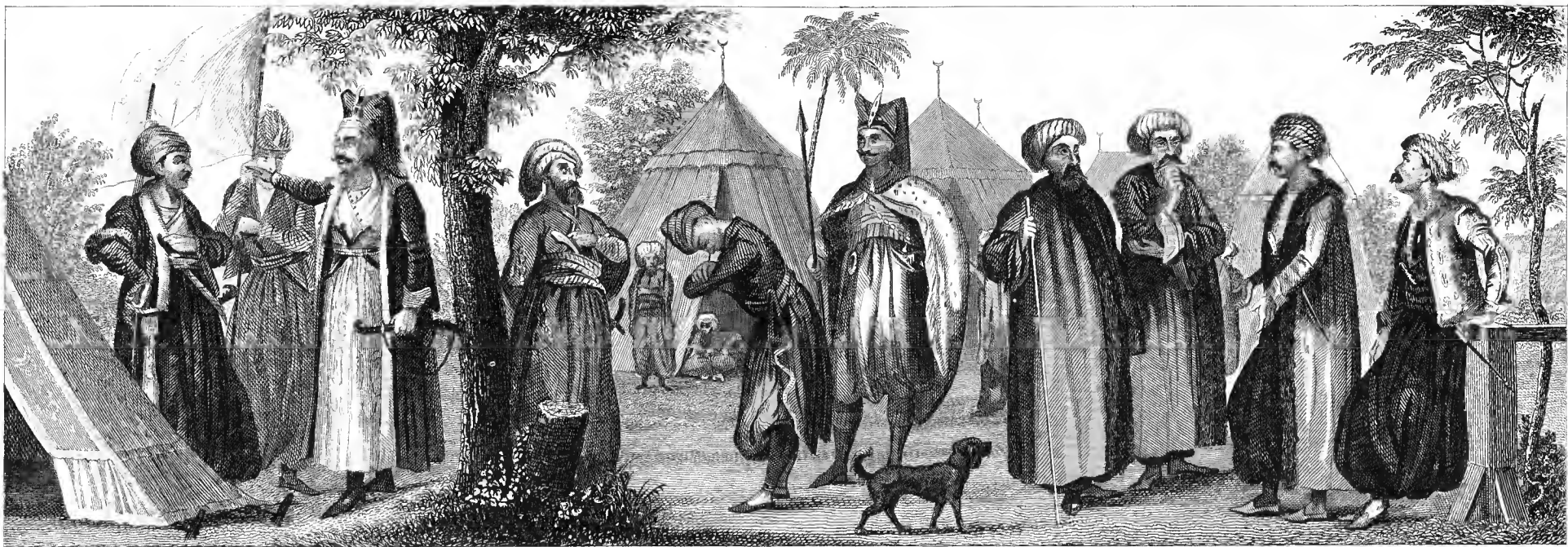
10



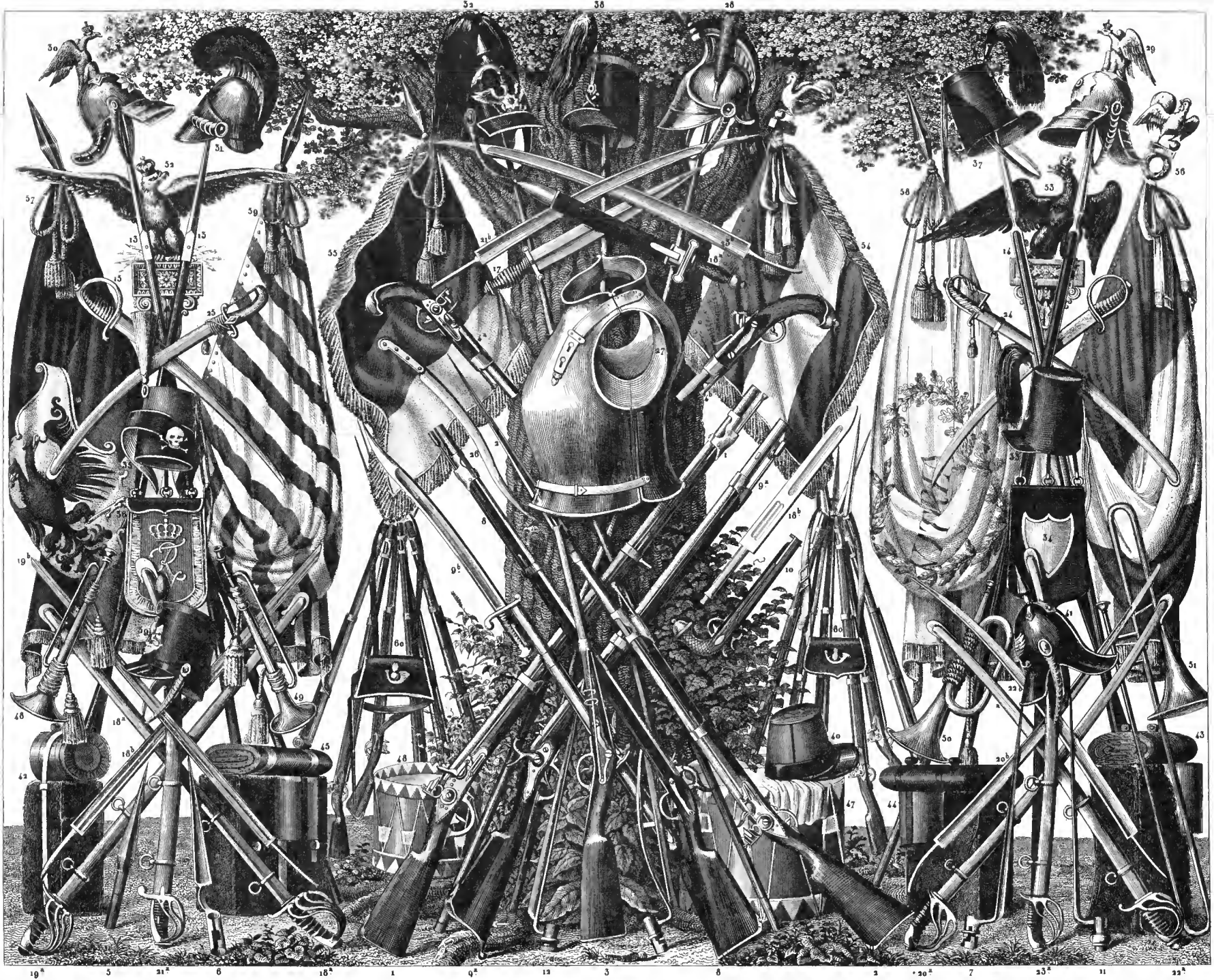












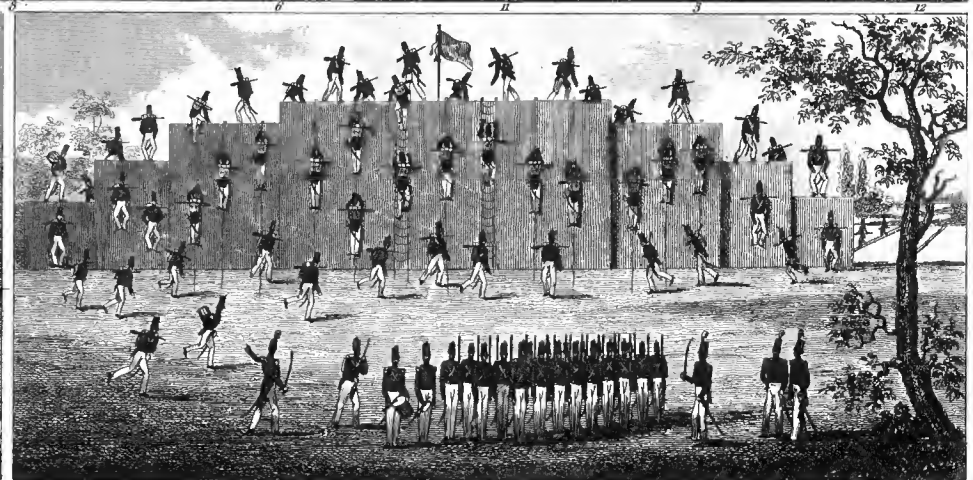
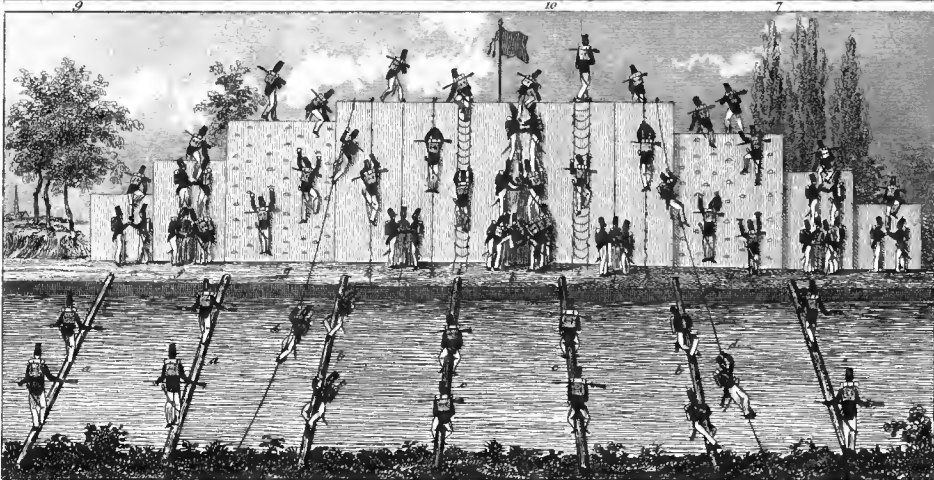
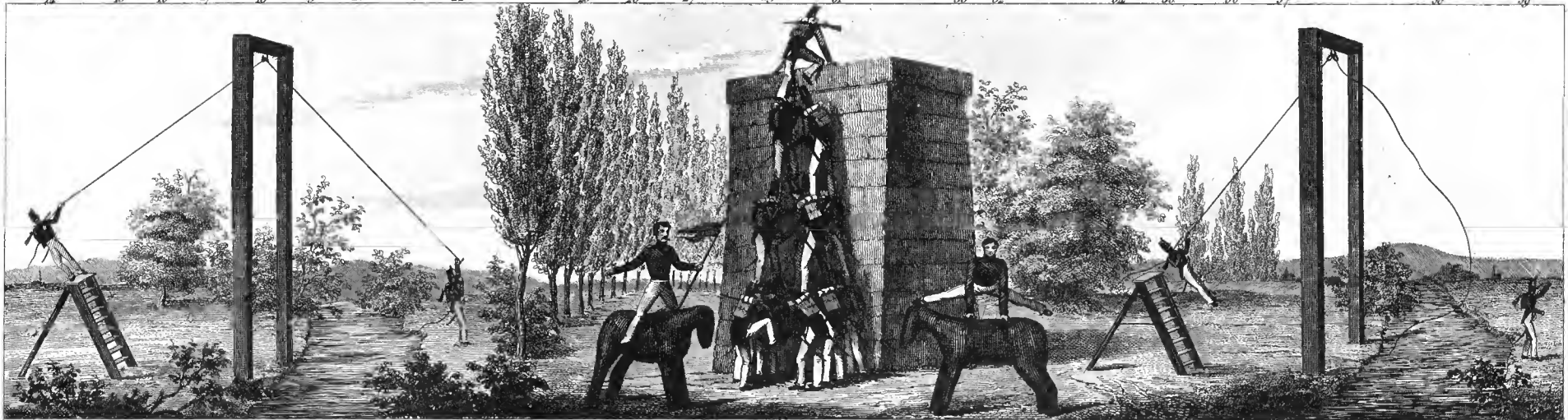
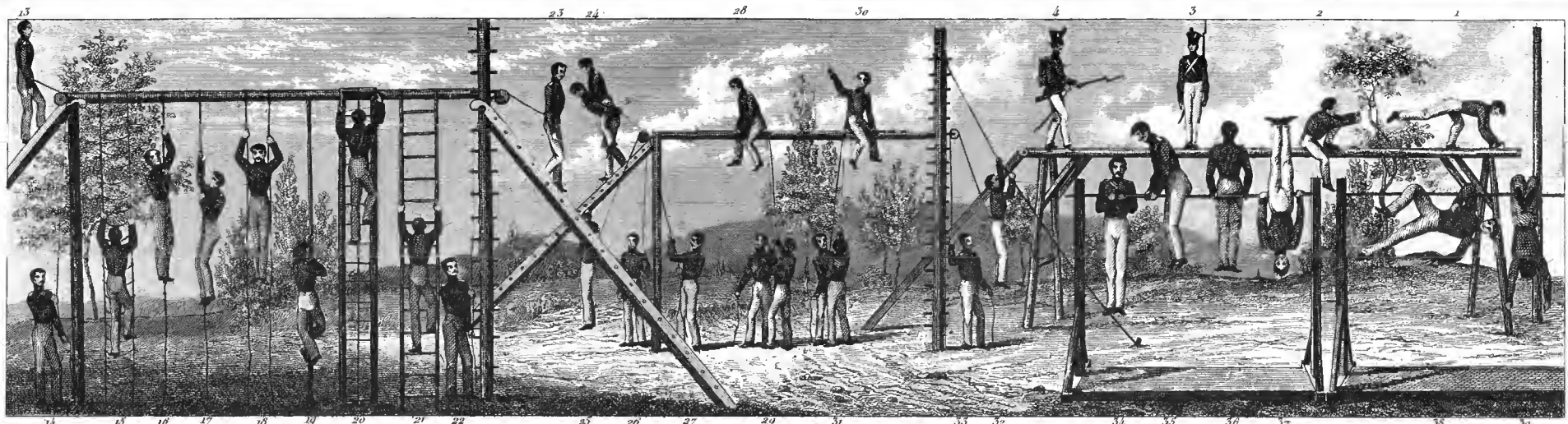
G. Heck dir.

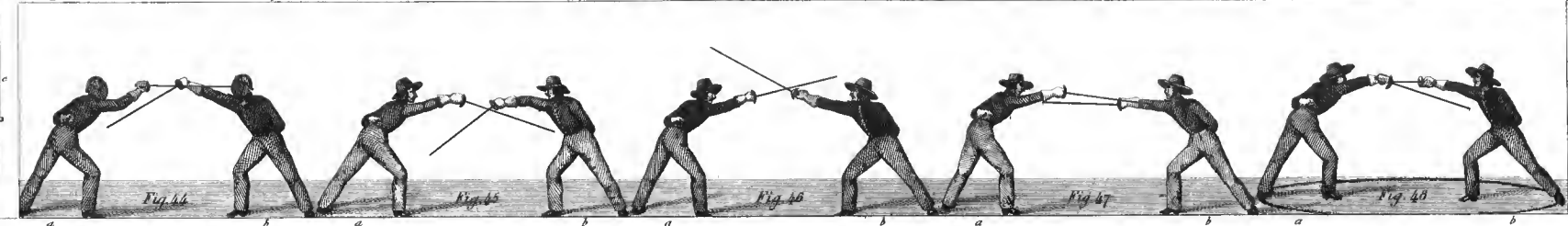
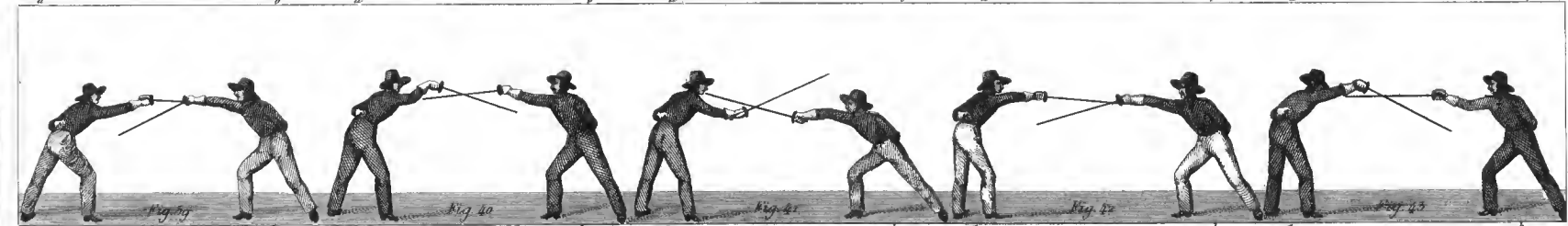
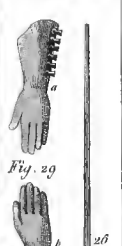
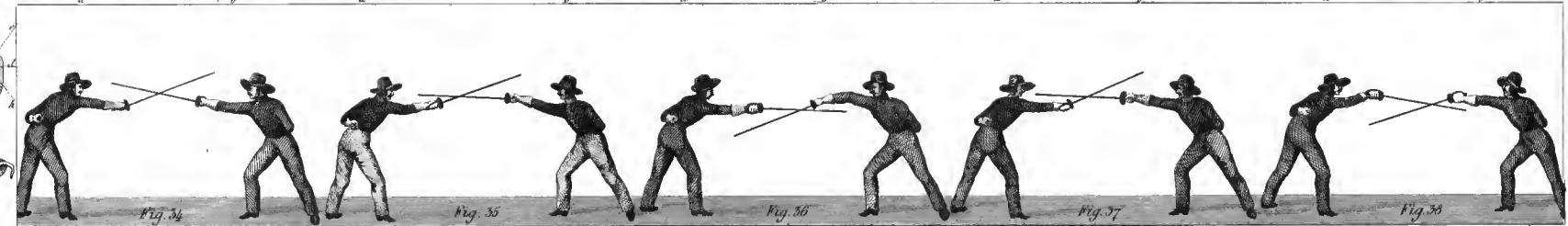
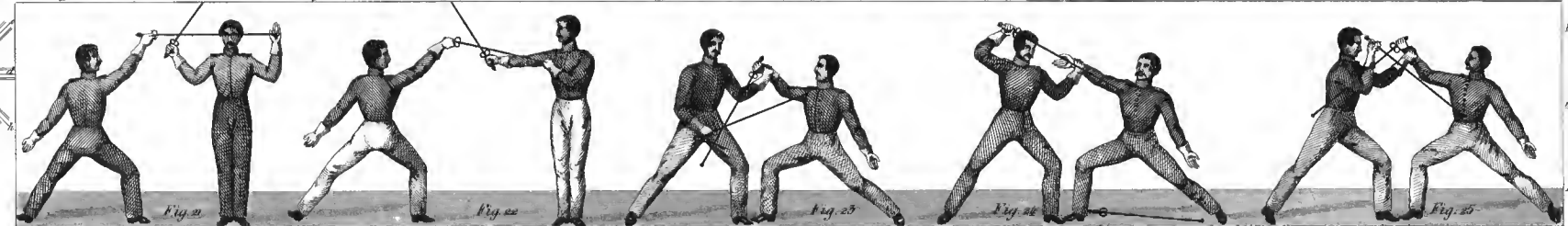
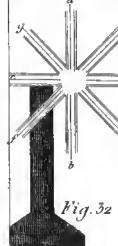
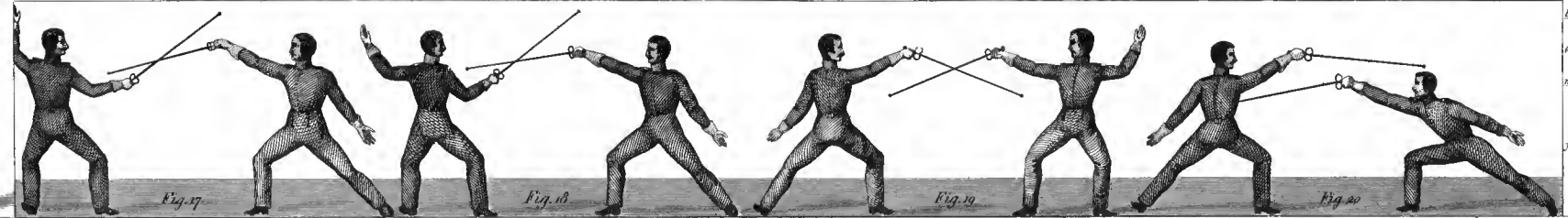
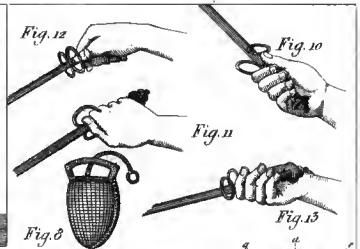
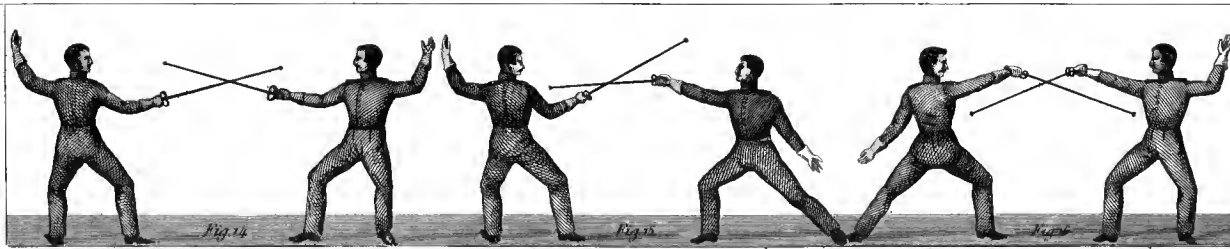
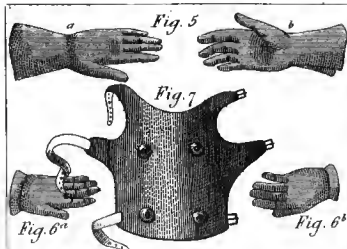
Maassstab für Fig. 18, 19, 20

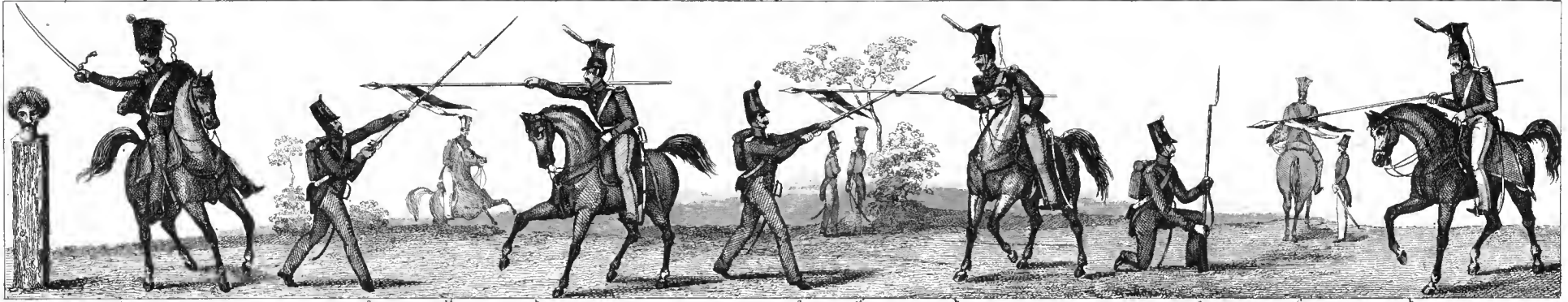
Maassstab für Fig. 21, 22, 23

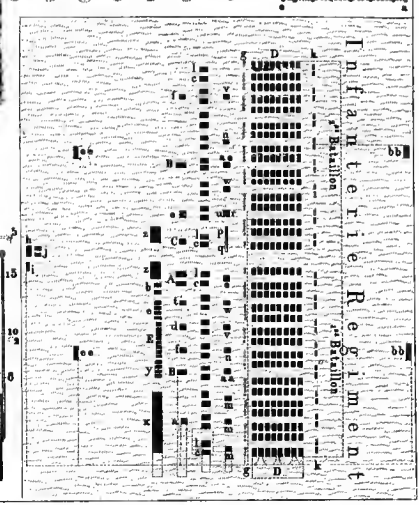
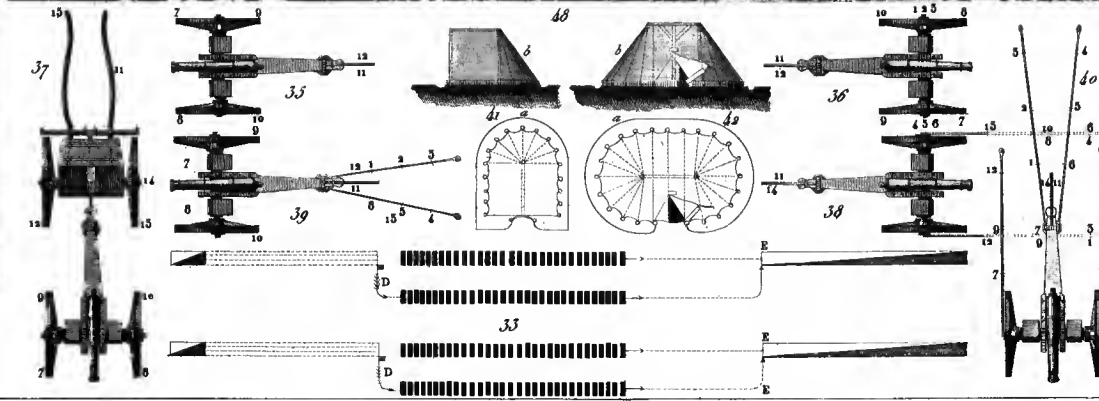
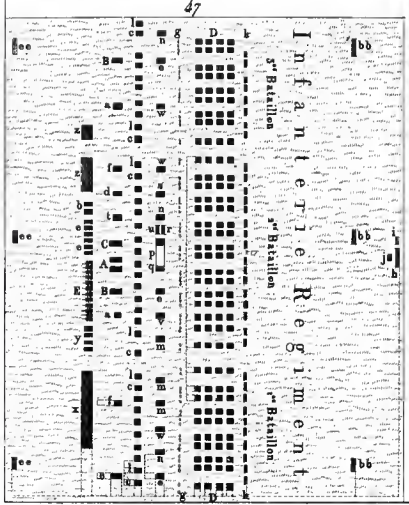
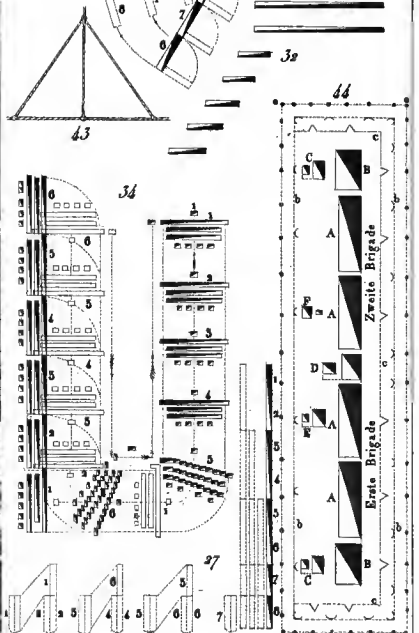
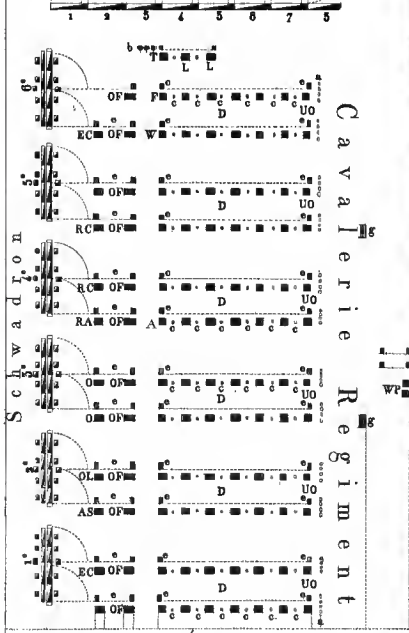
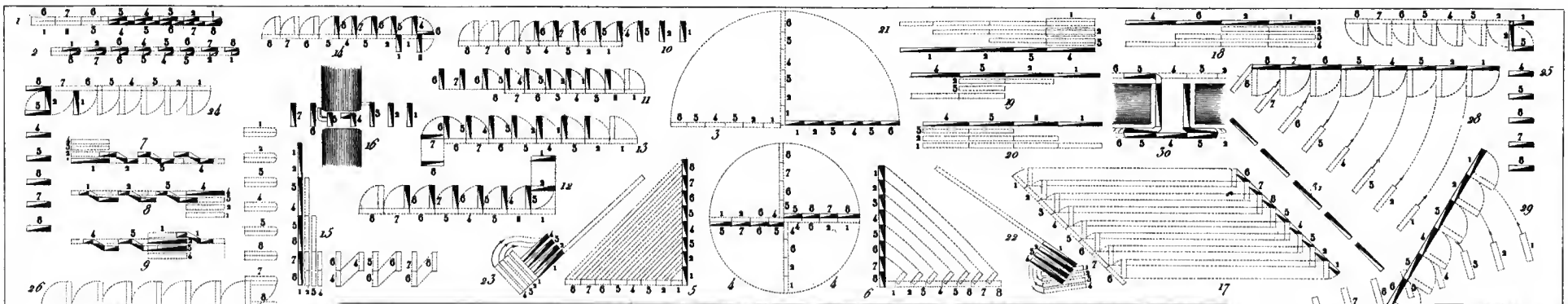
1 Mètre oder 100 Centimètres

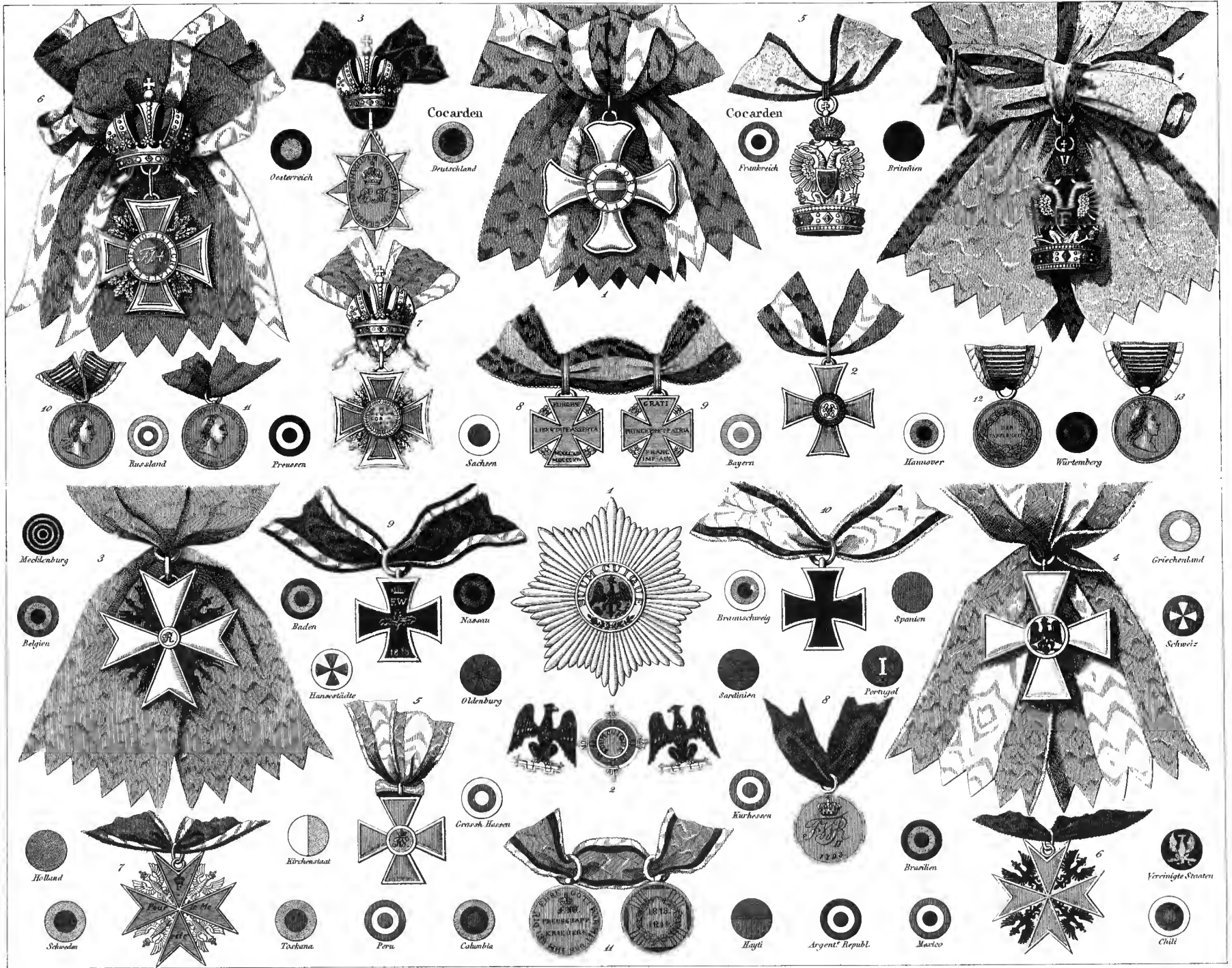
Schweissinger sculp.

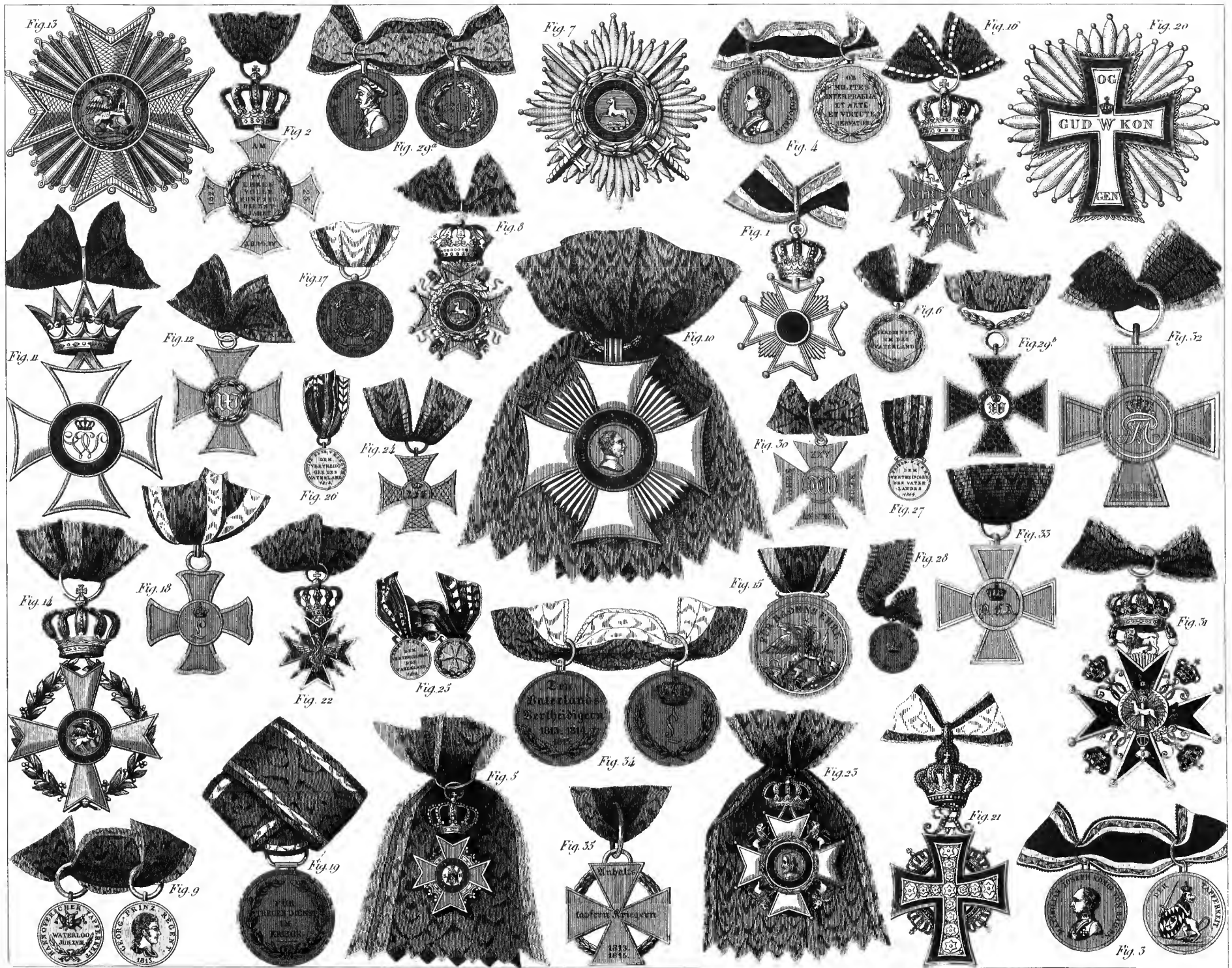




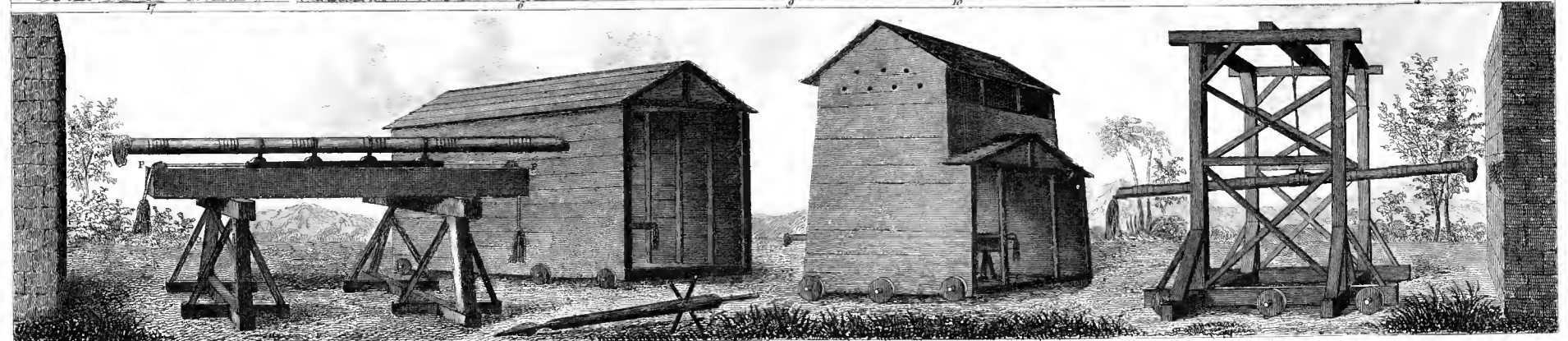
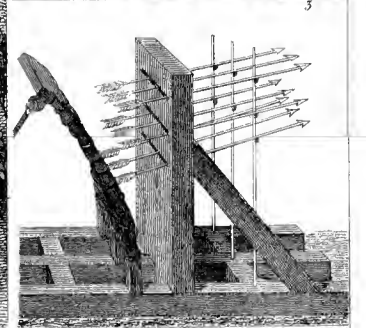
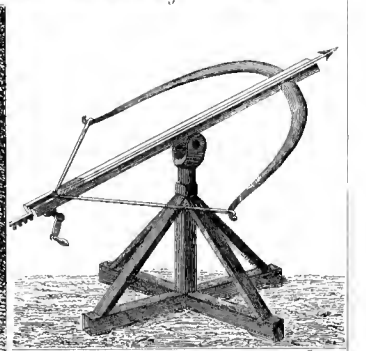
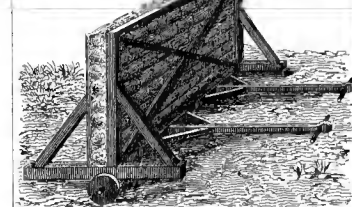
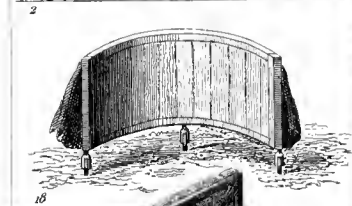
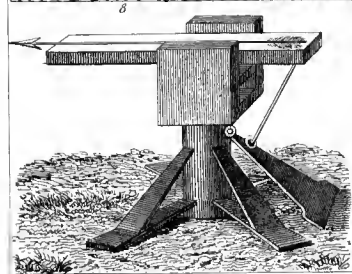
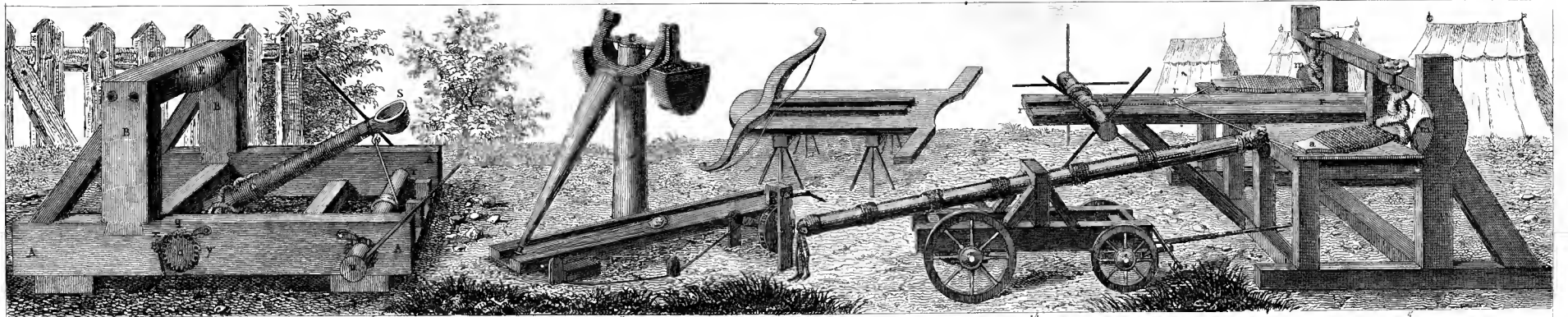


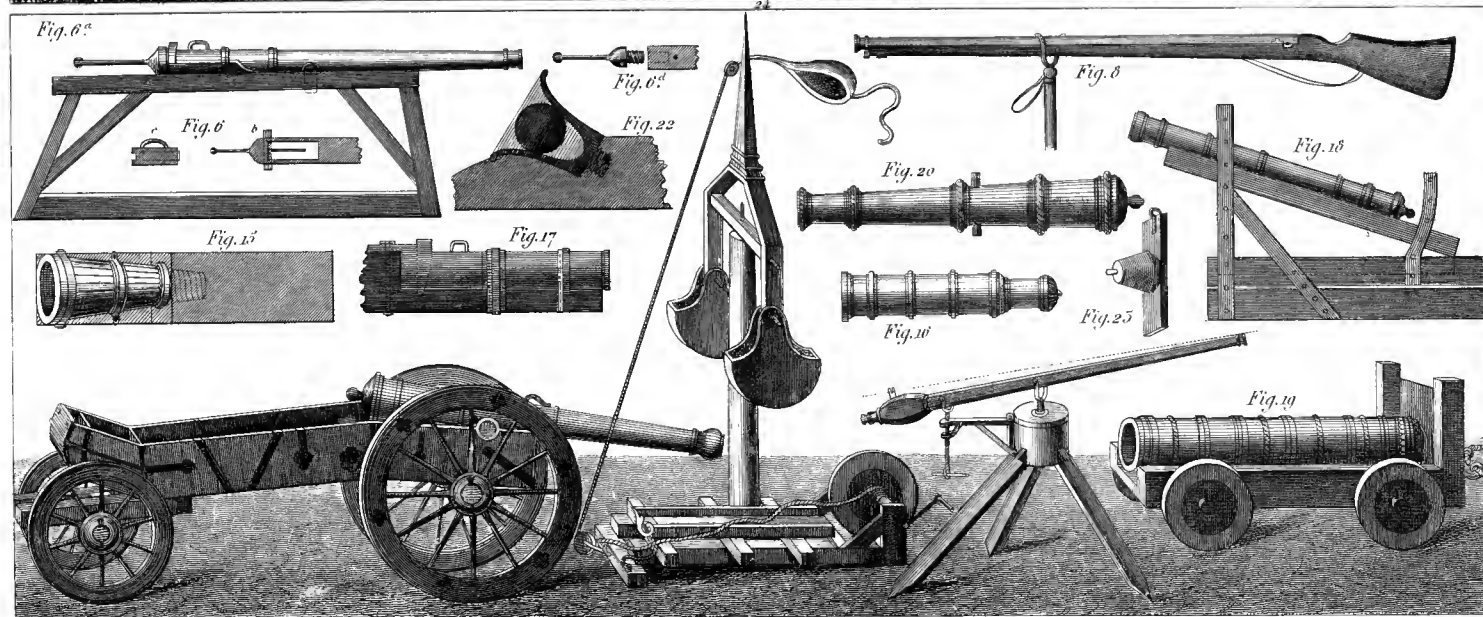
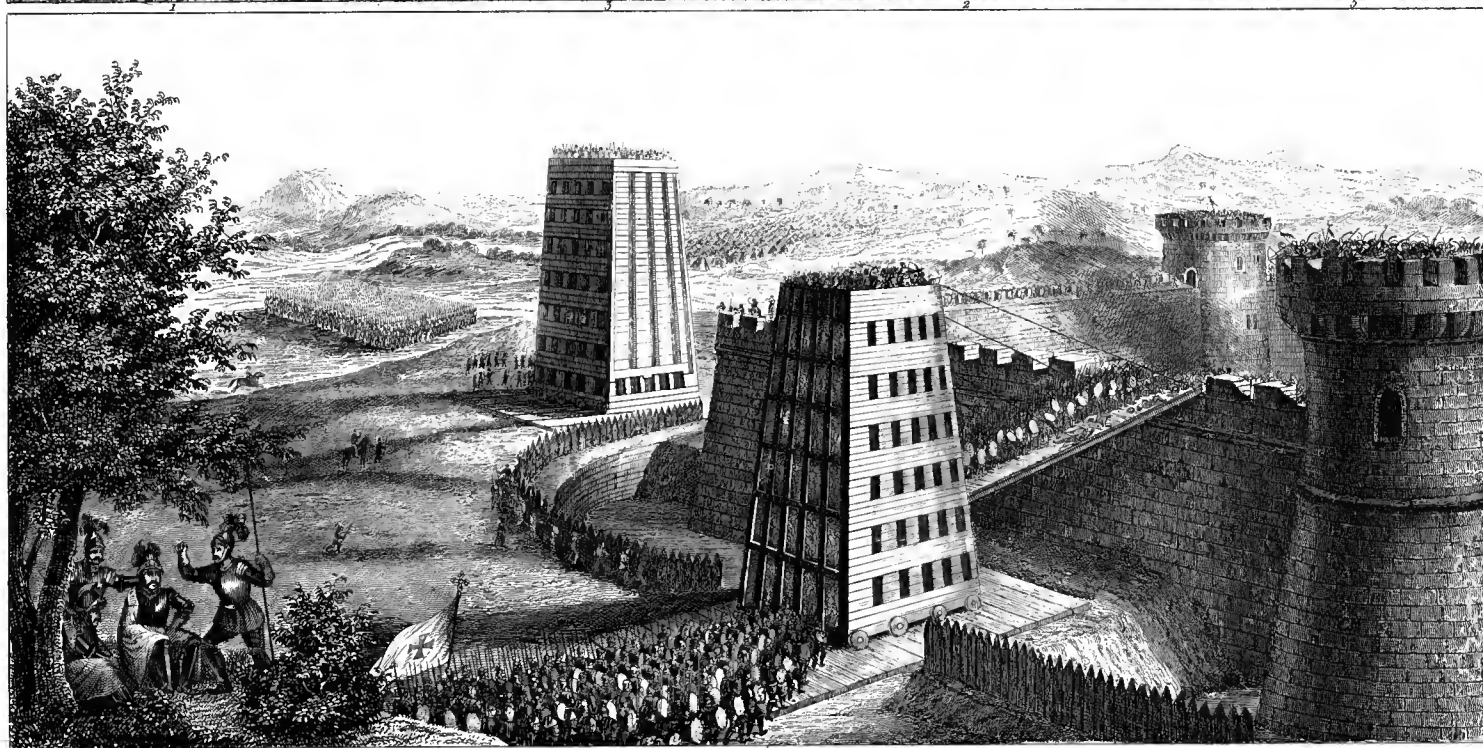
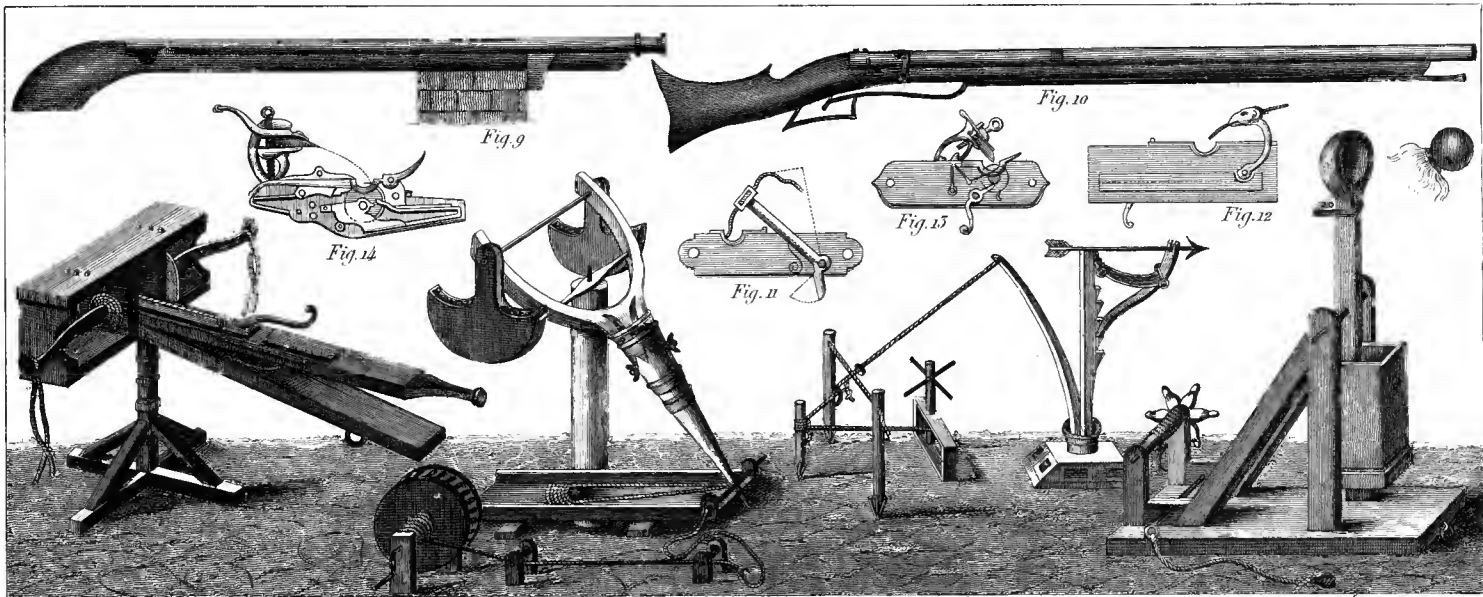


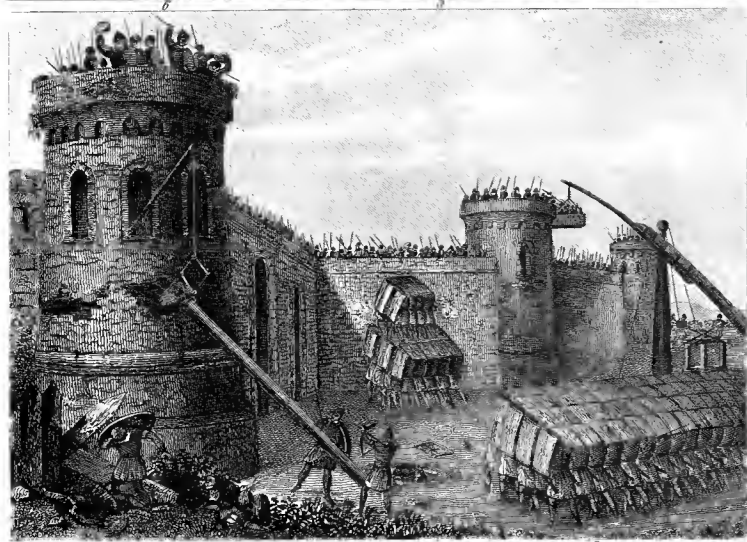
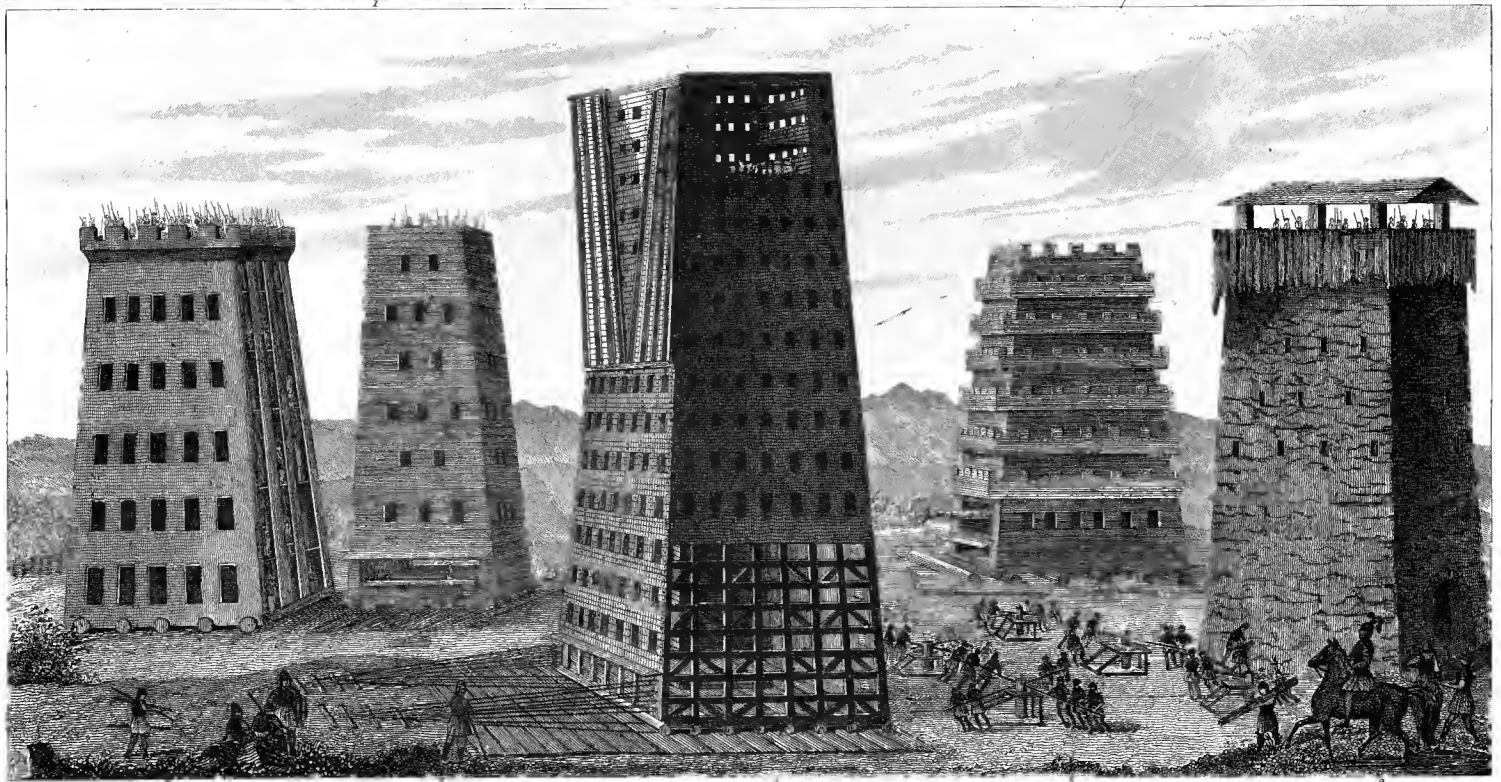
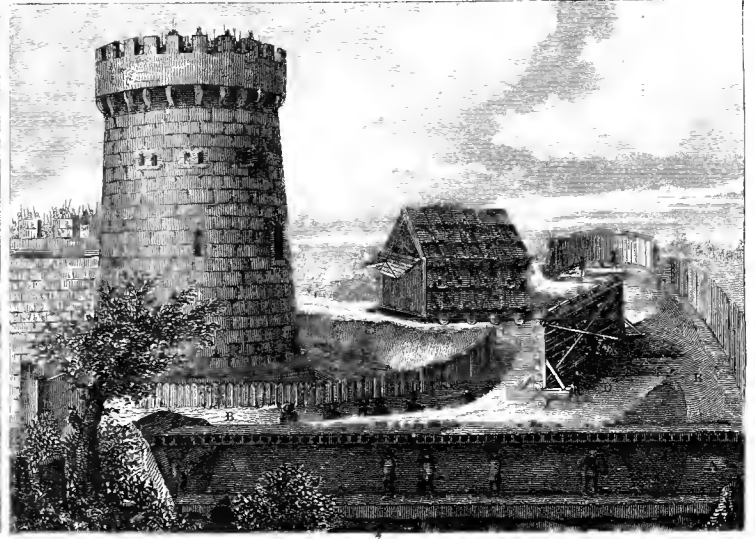
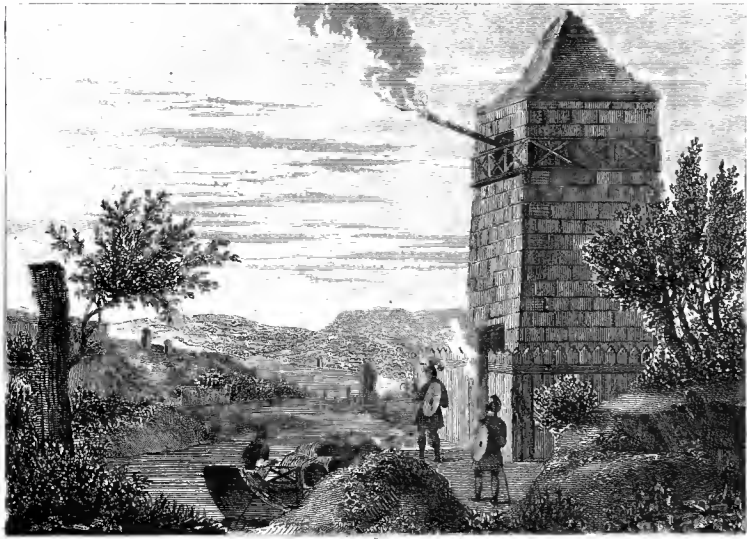










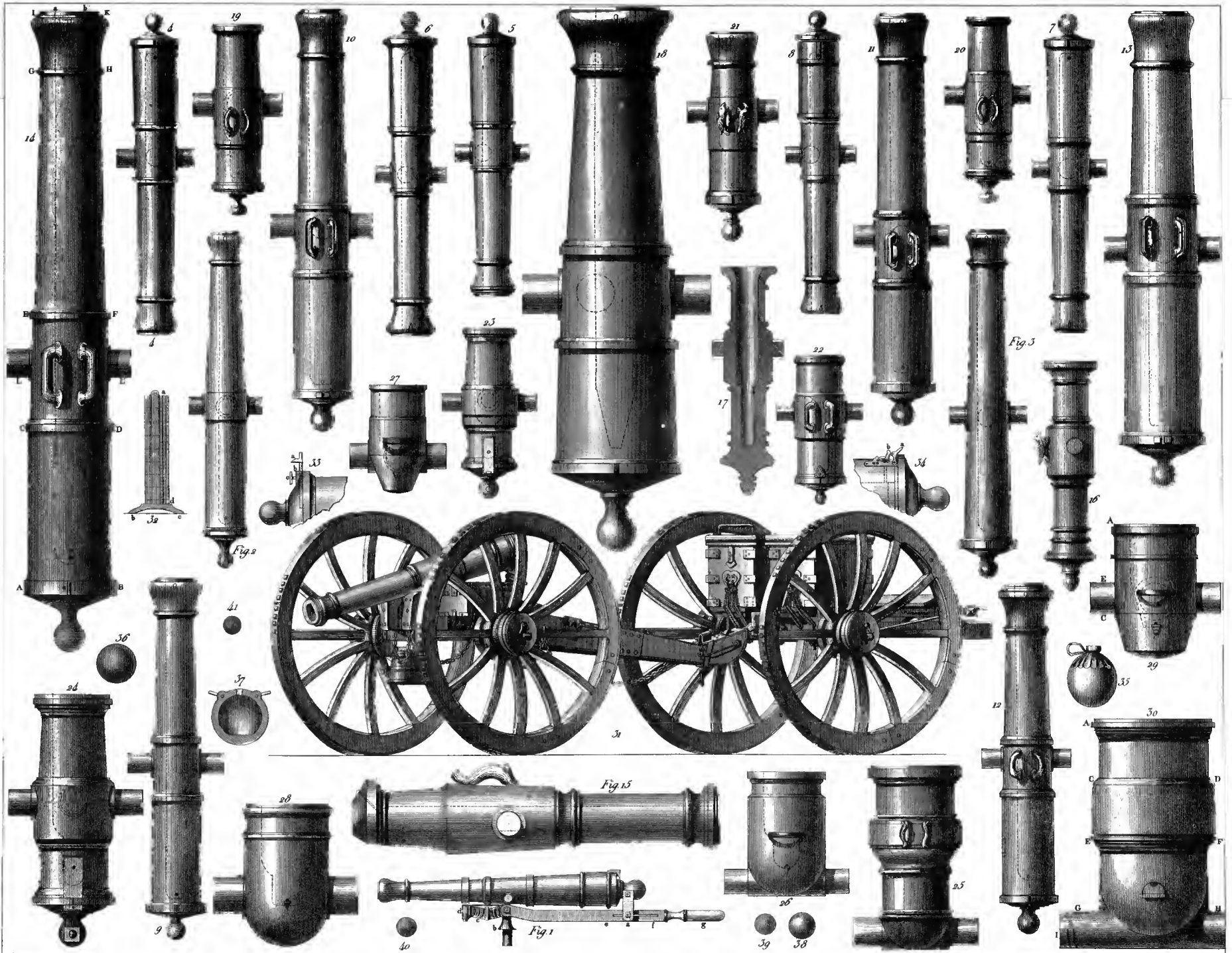


9

11

10

8



G. Foltberg sculp.

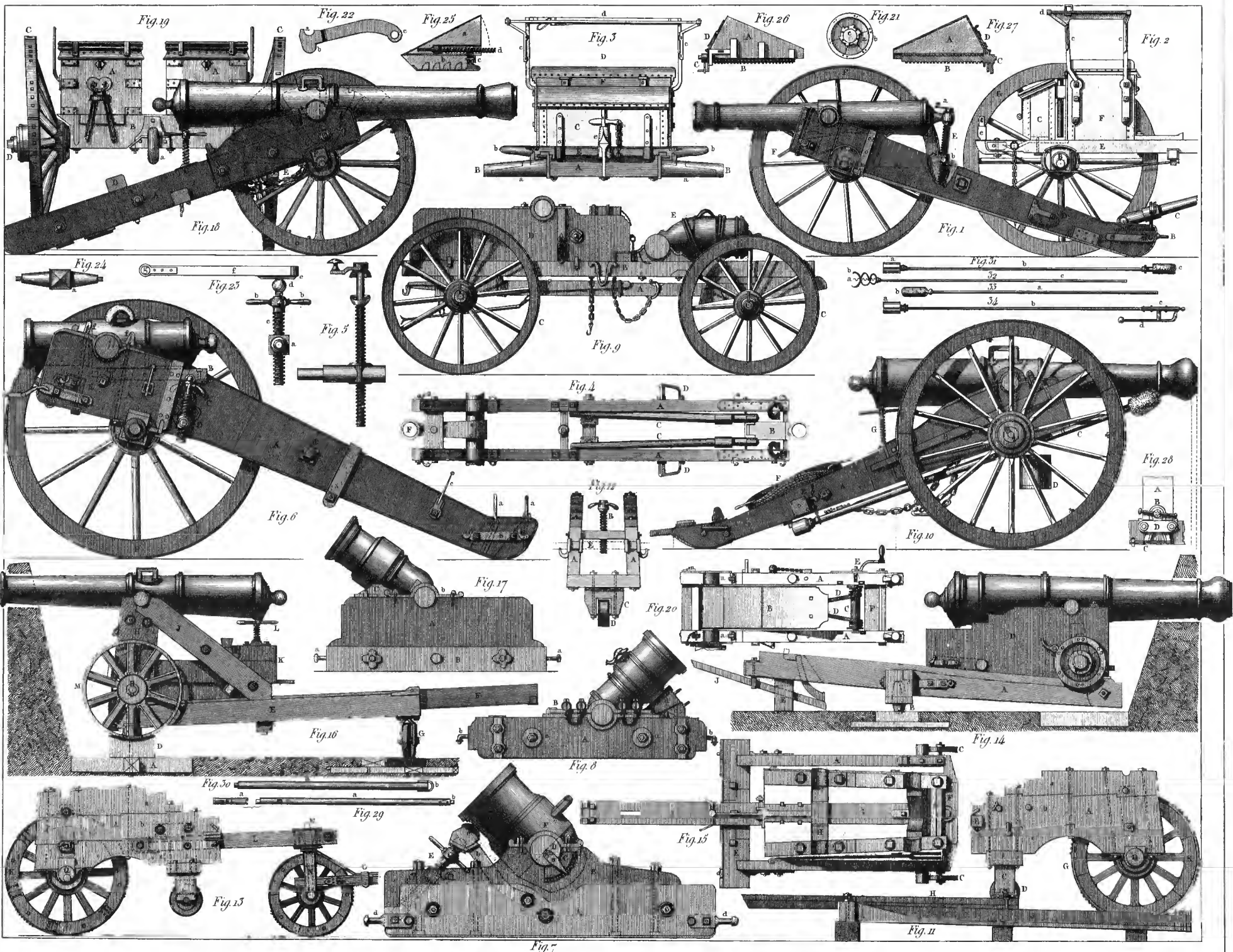


Fig. 19

Fig. 22

Fig. 23

Fig. 3

Fig. 26

Fig. 21

Fig. 27

Fig. 2

Fig. 18

Fig. 1

Fig. 24

Fig. 25

Fig. 5

Fig. 9

Fig. 31

Fig. 4

Fig. 6

Fig. 28

Fig. 17

Fig. 20

Fig. 10

Fig. 16

Fig. 8

Fig. 14

Fig. 30

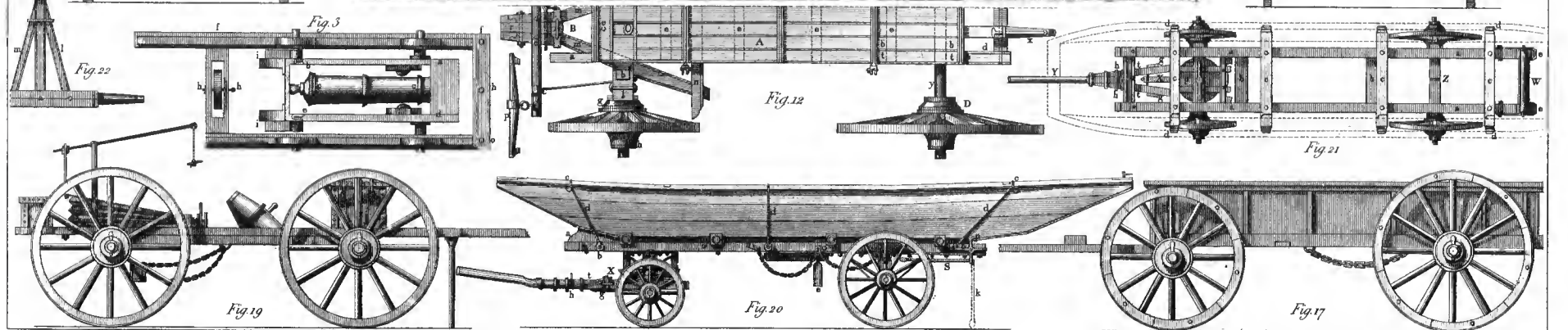
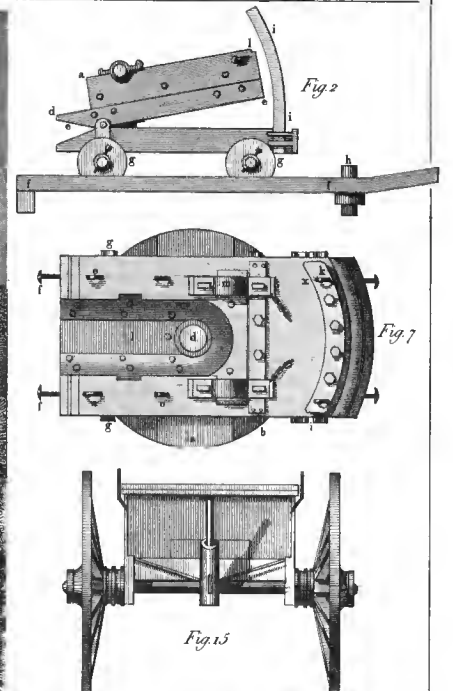
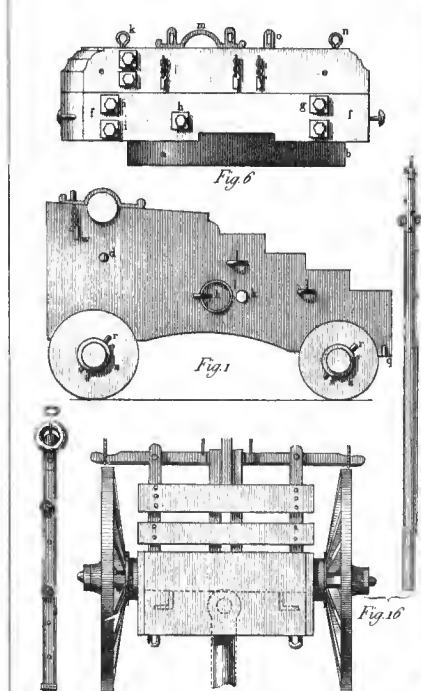
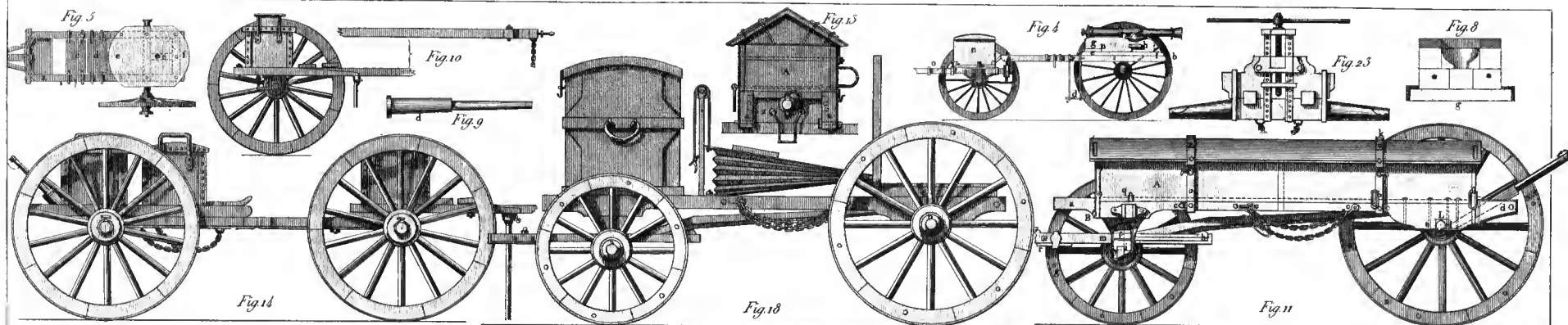
Fig. 29

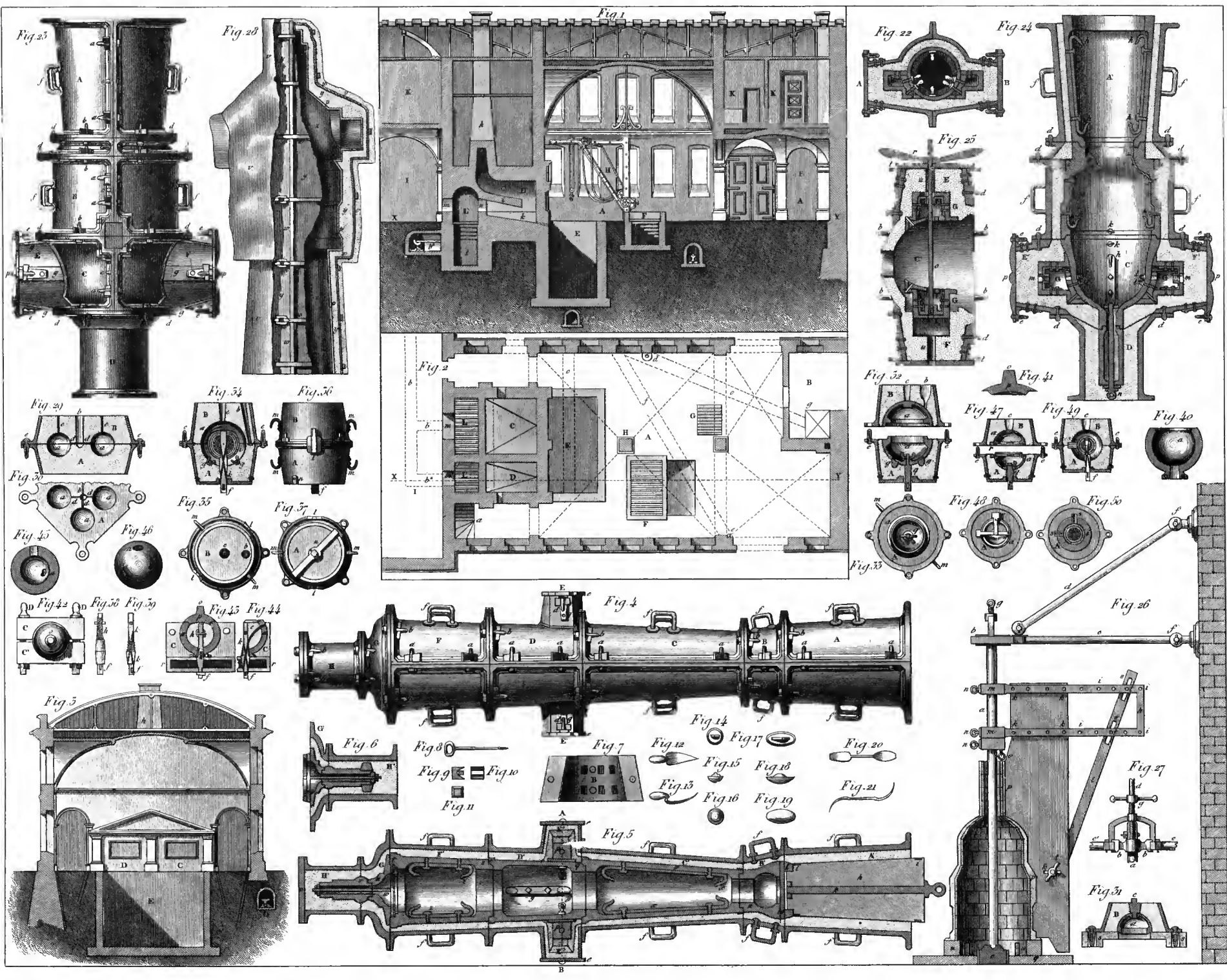
Fig. 15

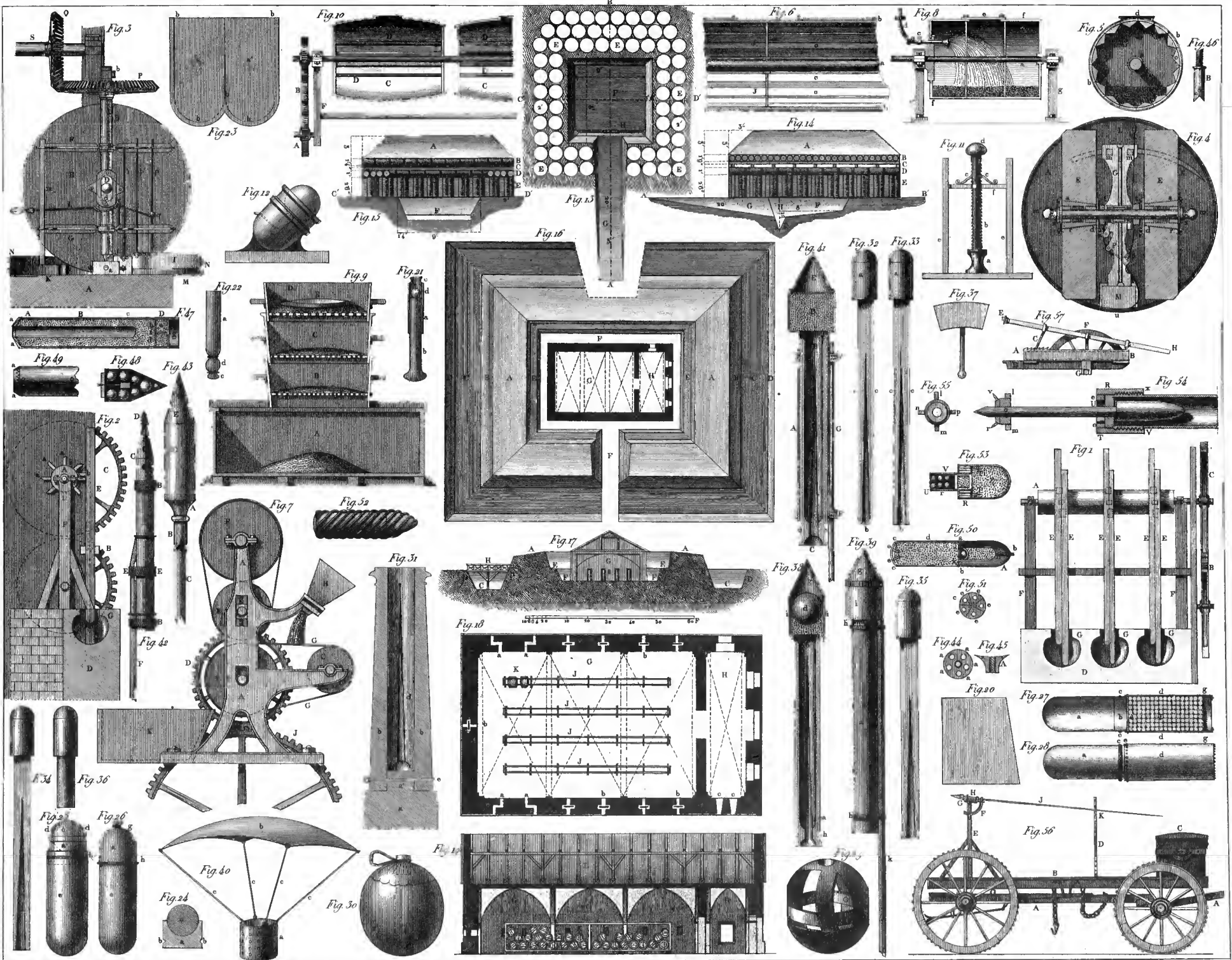
Fig. 13

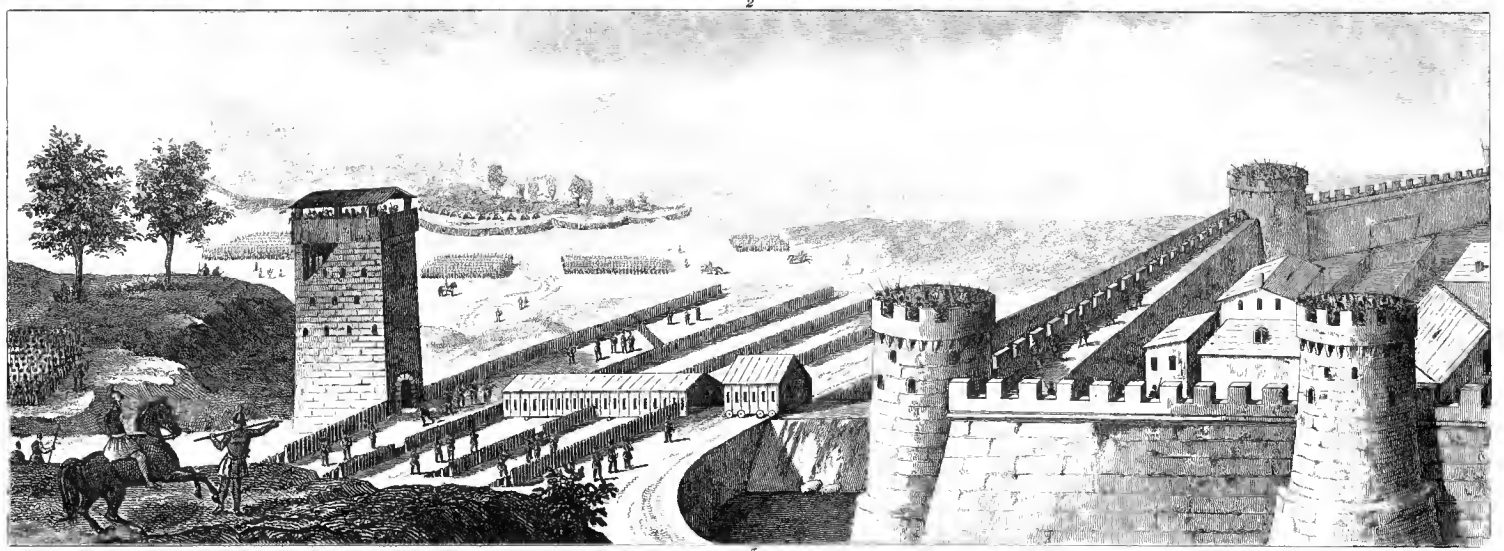
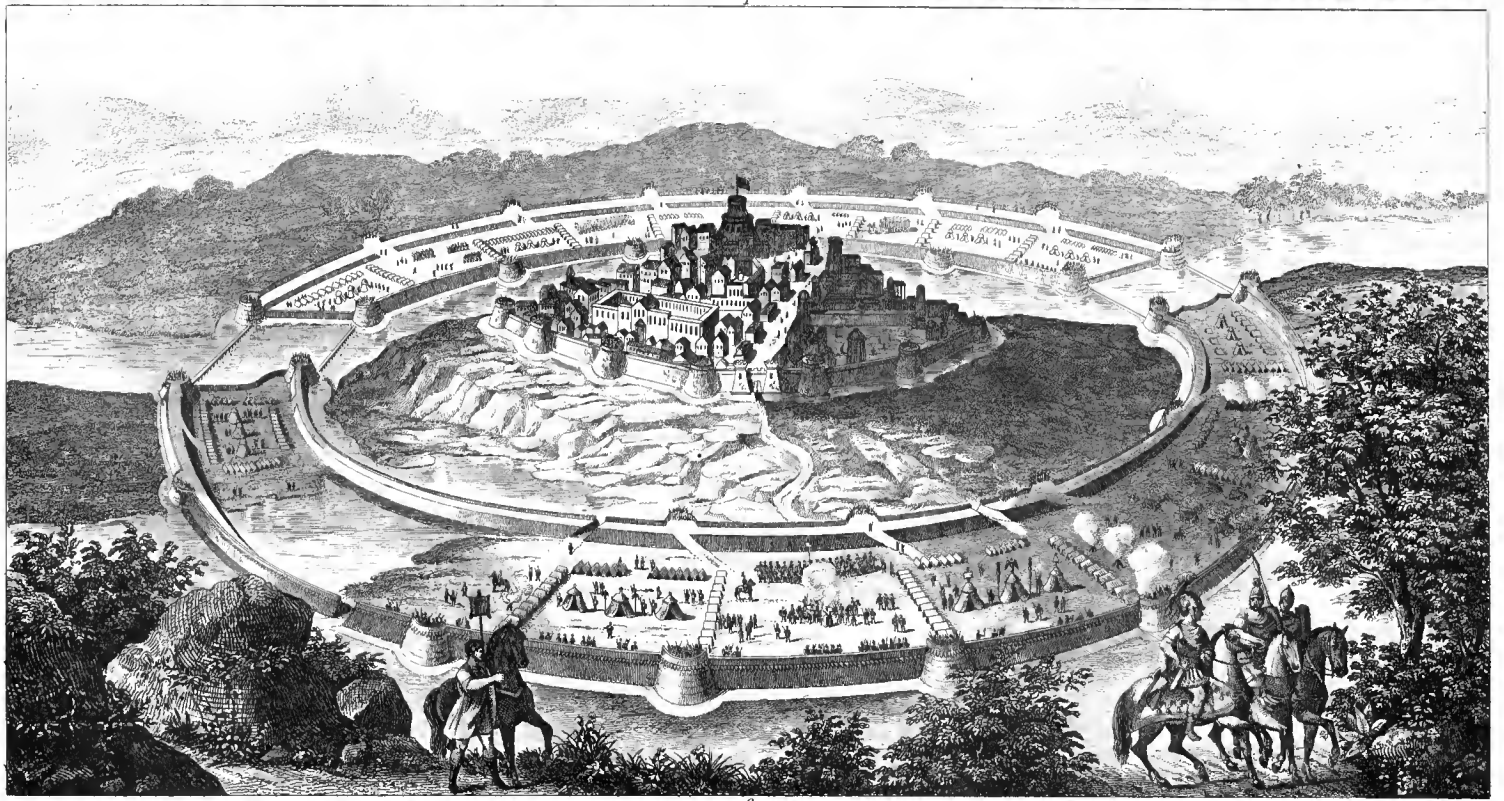
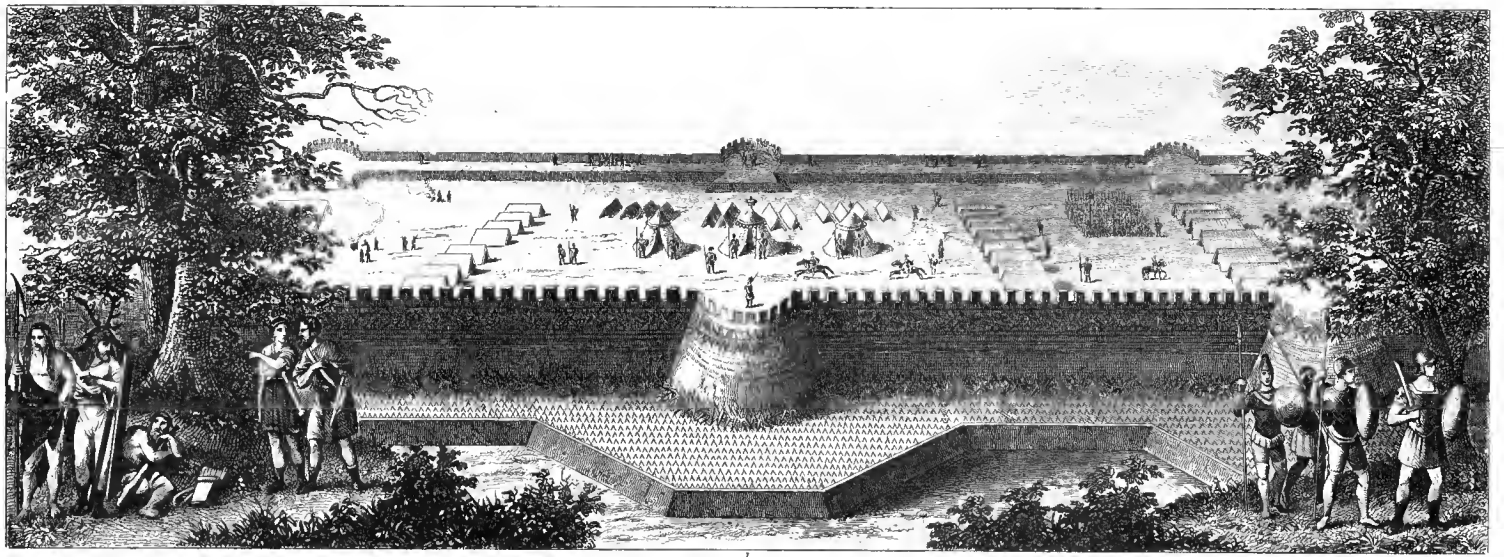
Fig. 7

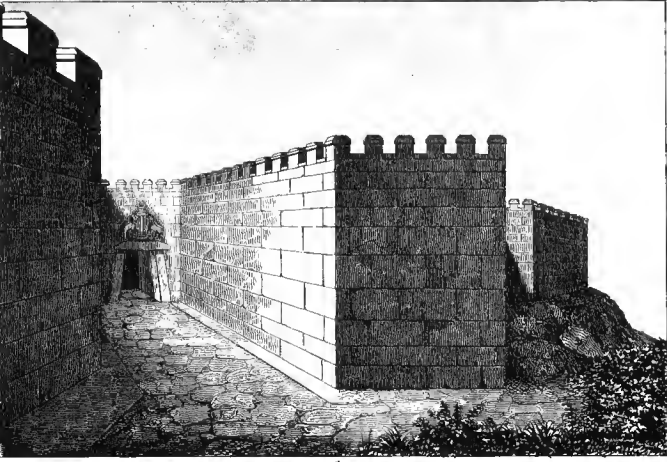
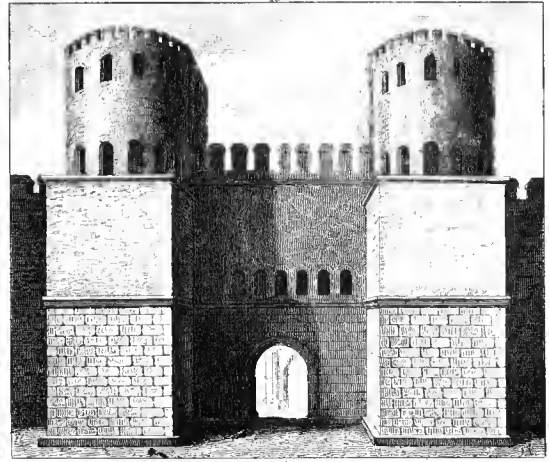
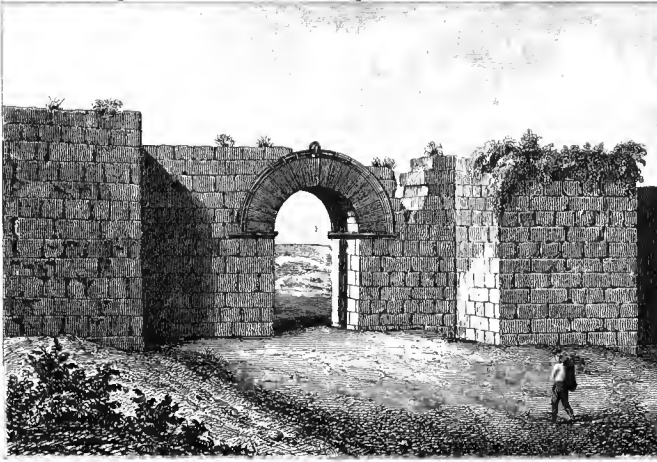
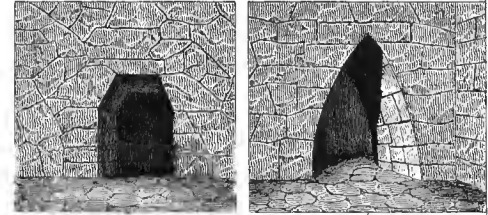
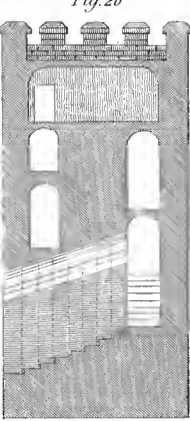
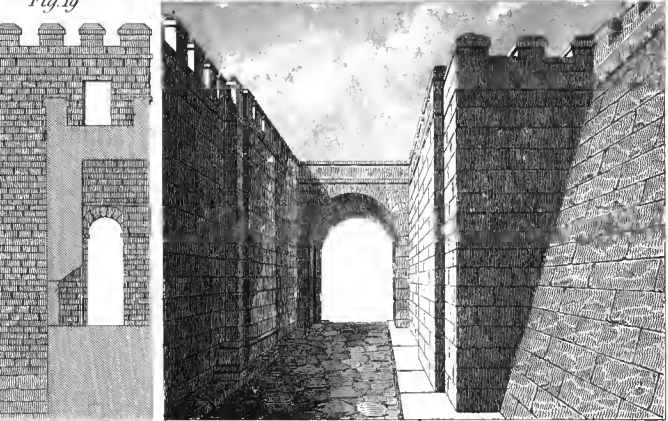
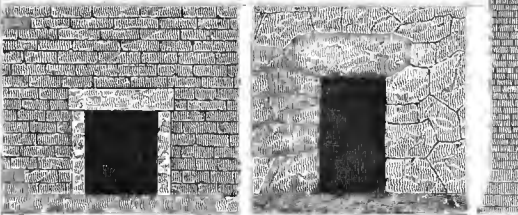
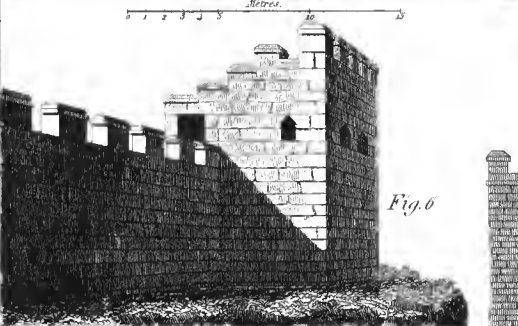
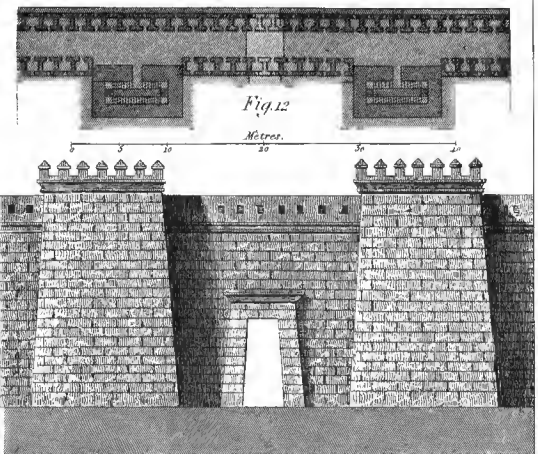
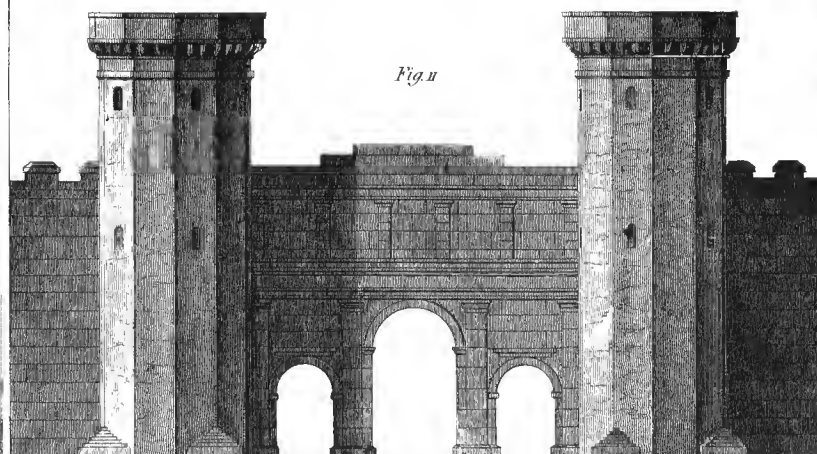
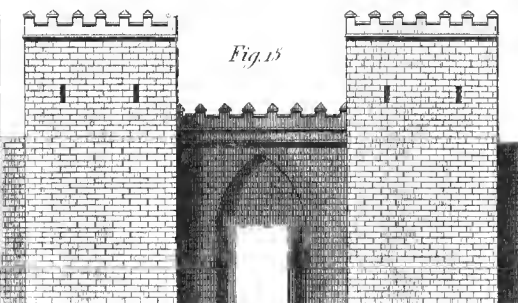
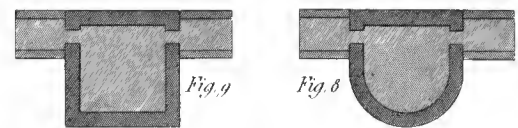
Fig. 11

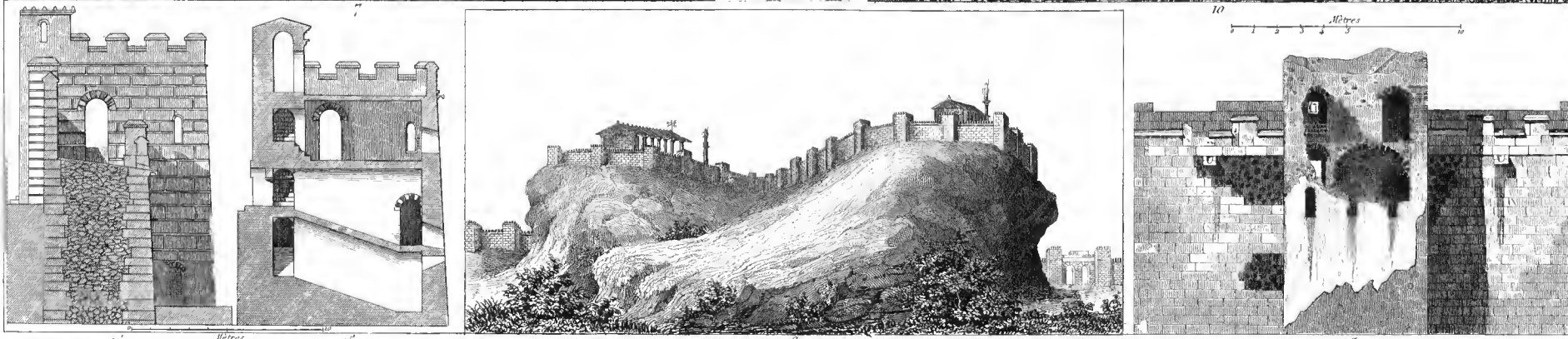
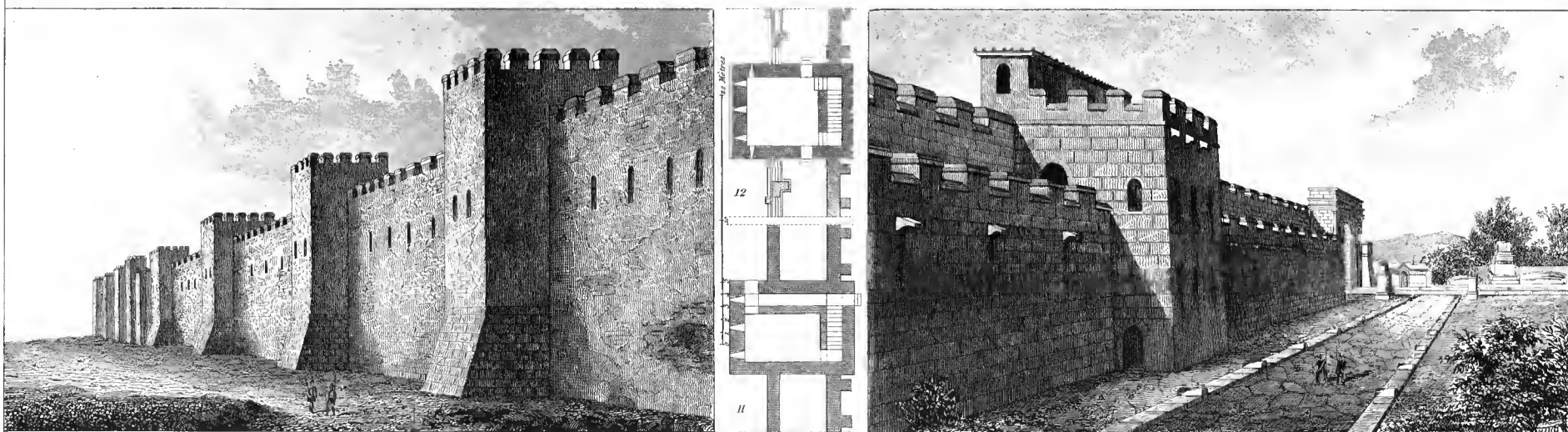
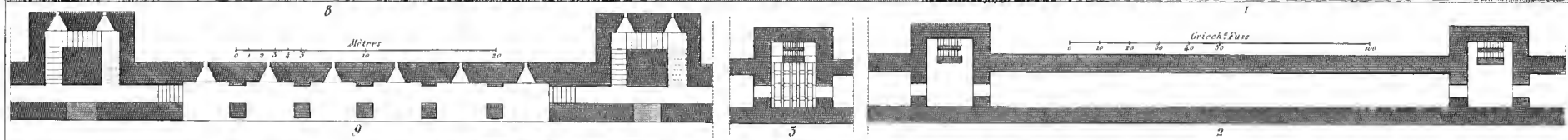
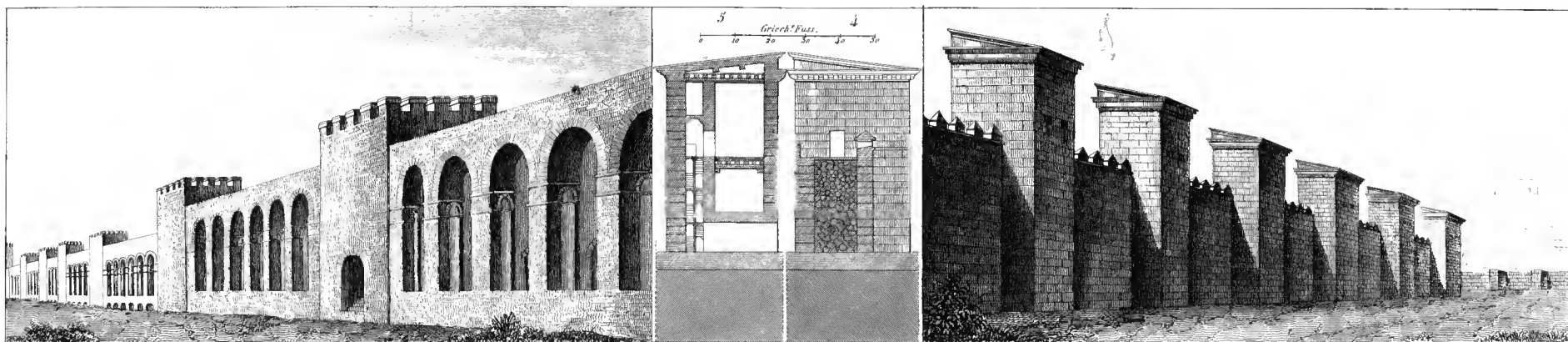












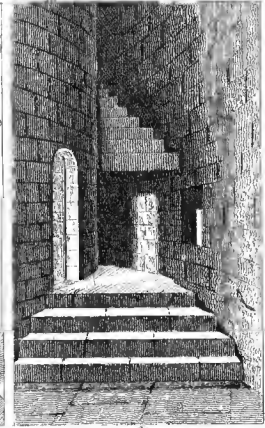
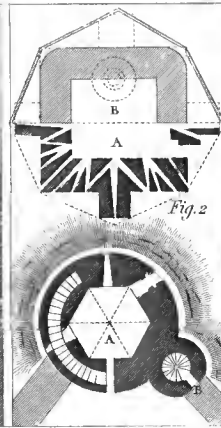
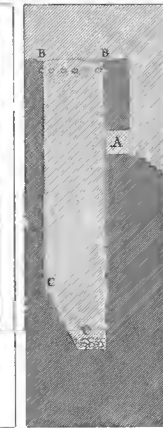
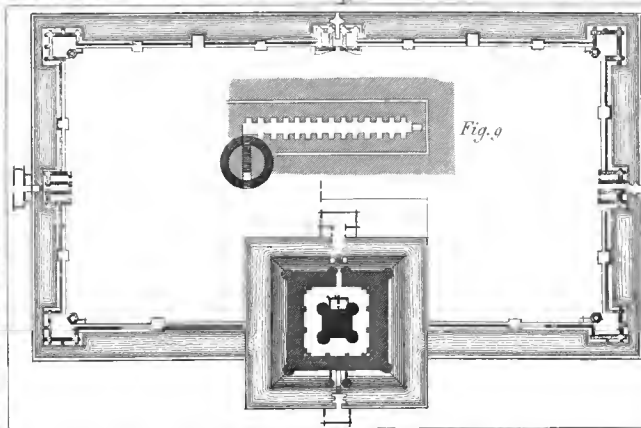
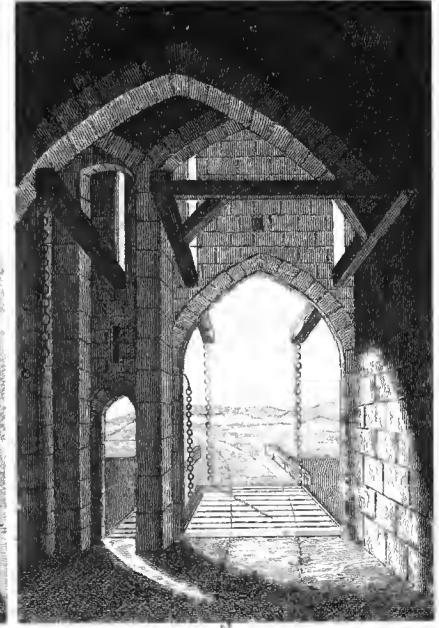
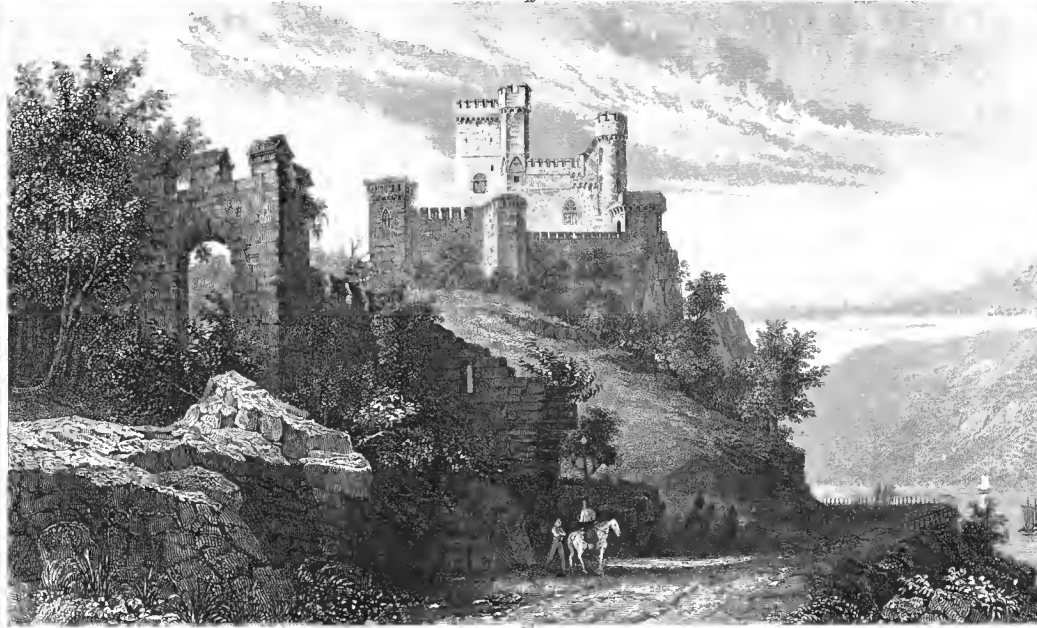
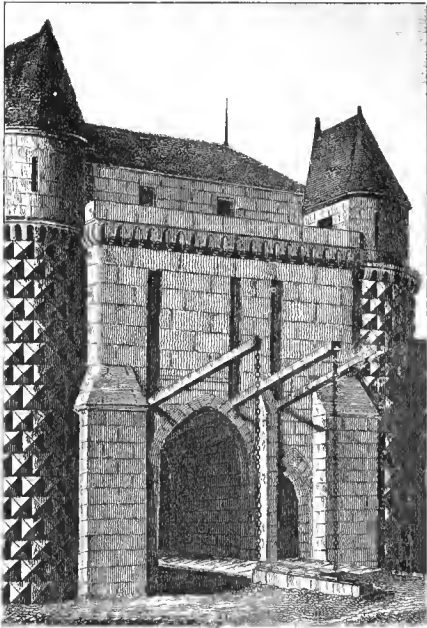
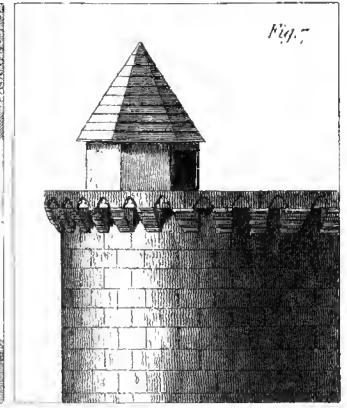
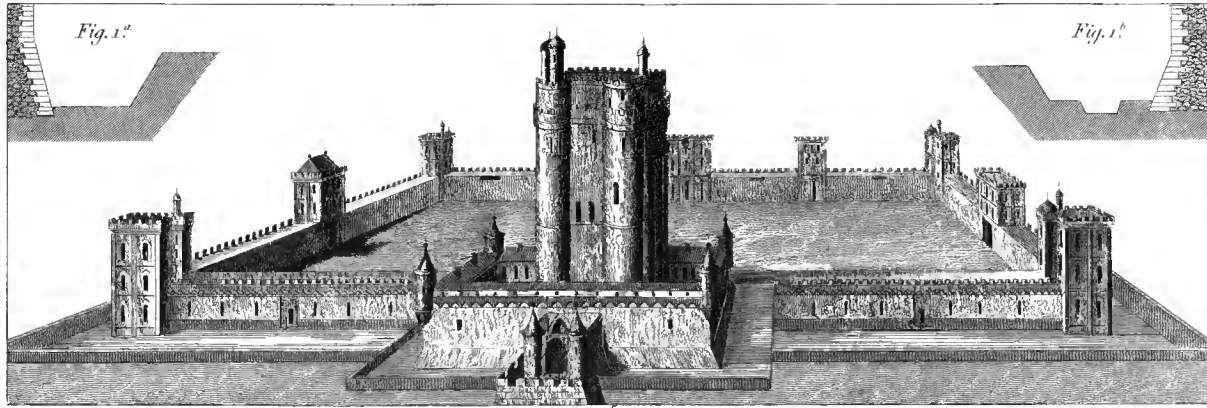
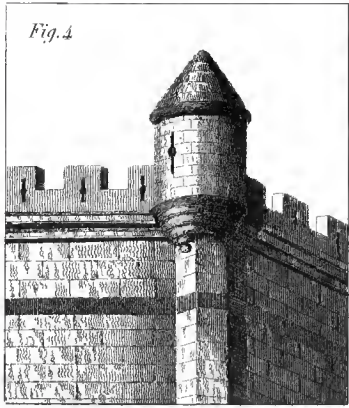
14

Mètres

13

6

15



8

10

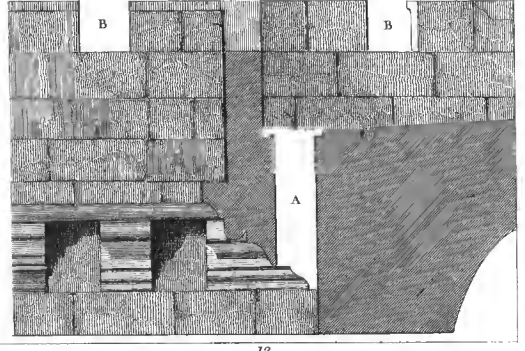
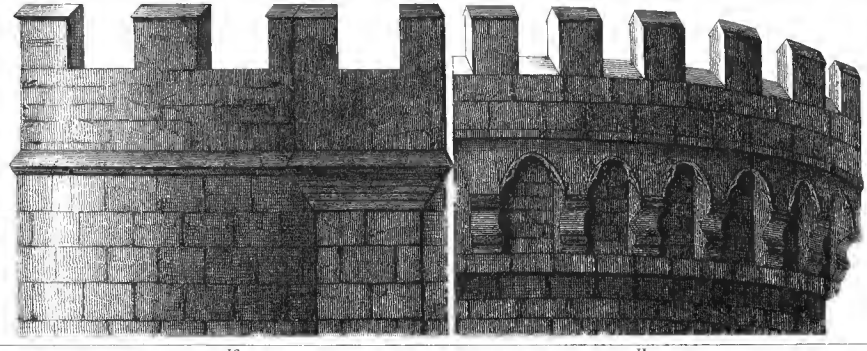
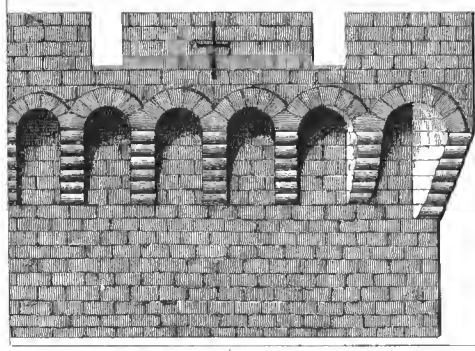
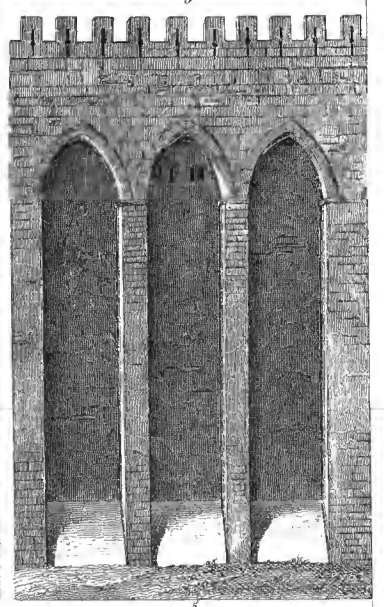
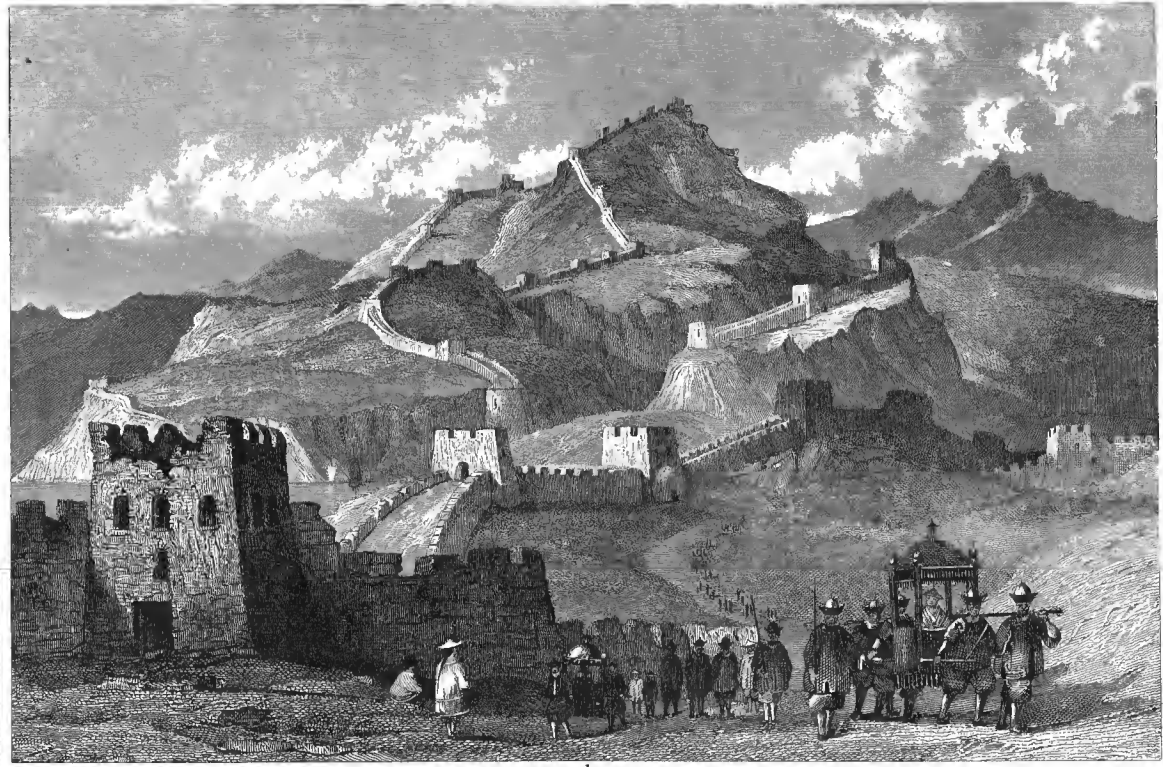
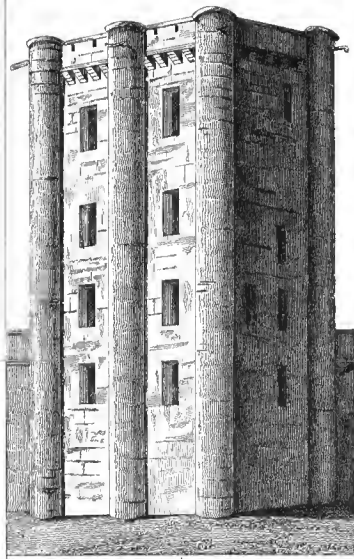
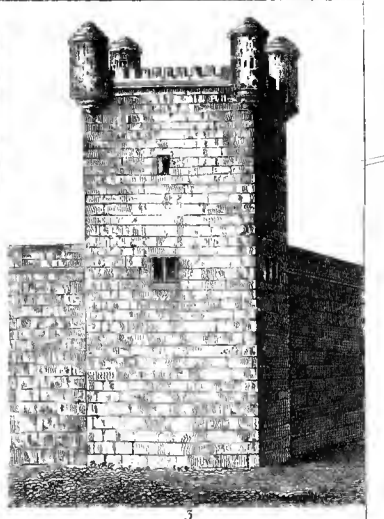
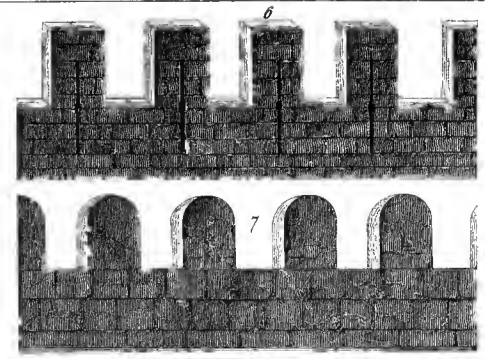
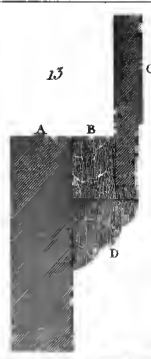
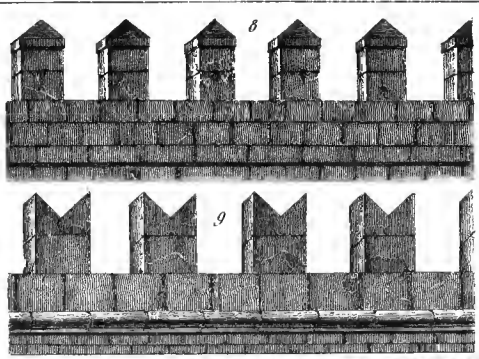
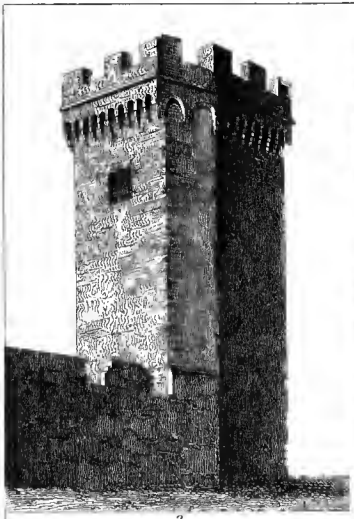
11

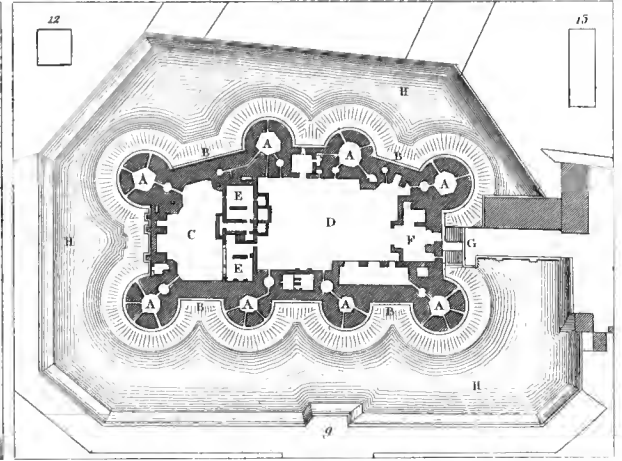
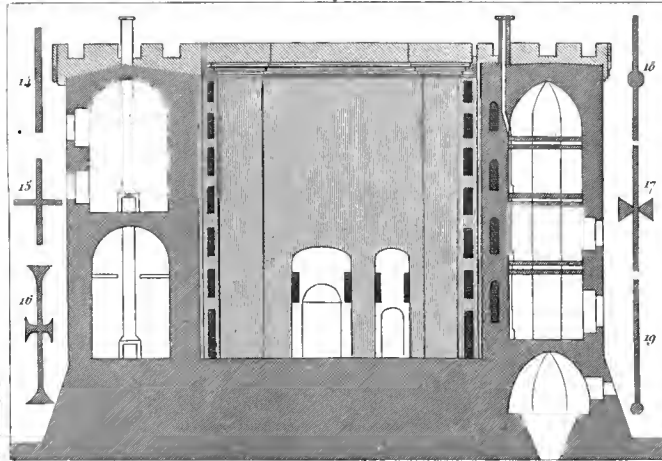
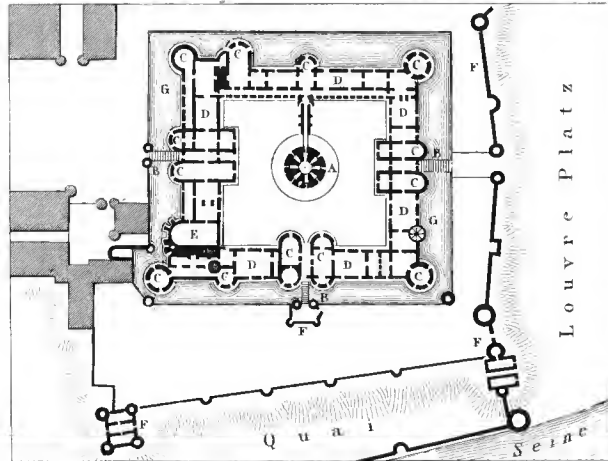
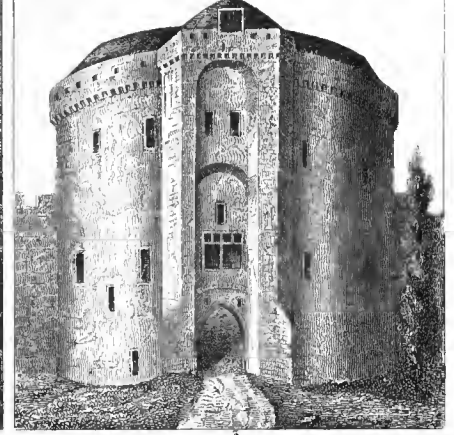
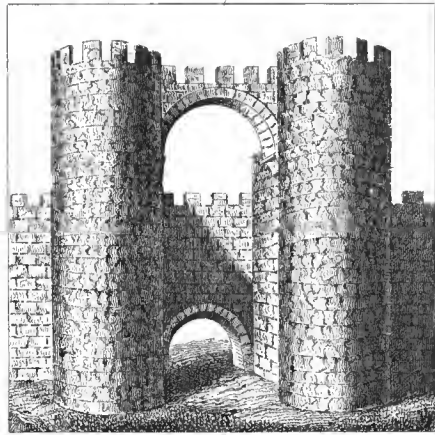
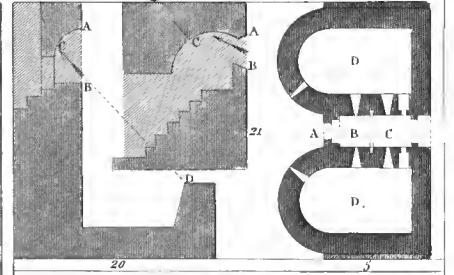
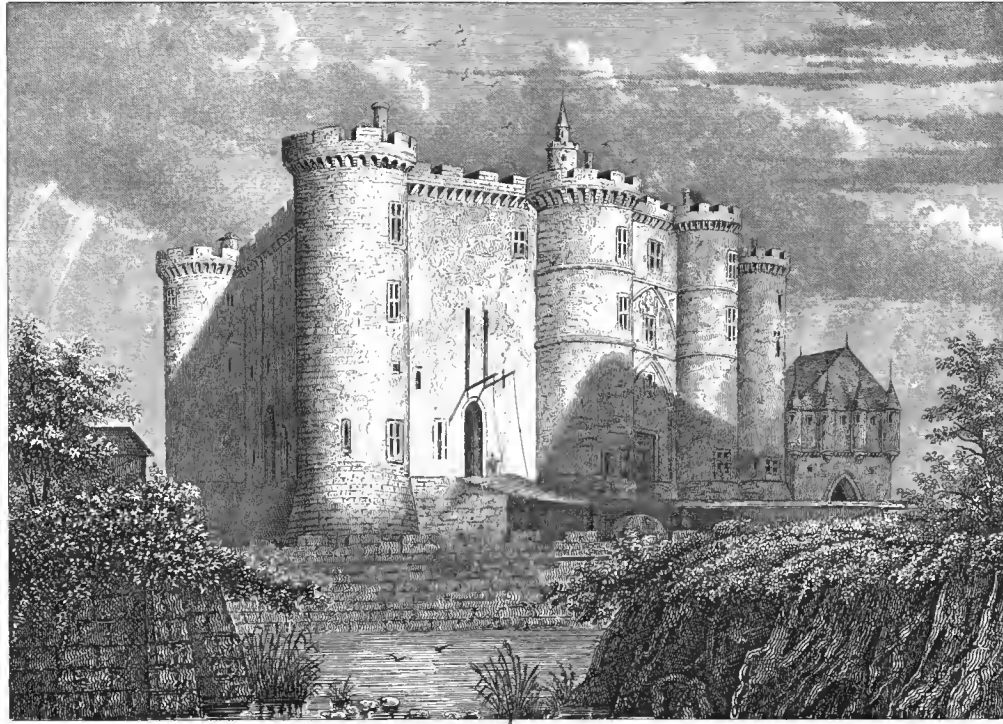
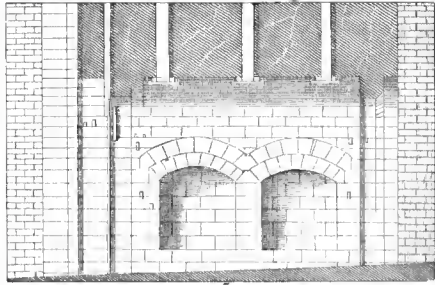
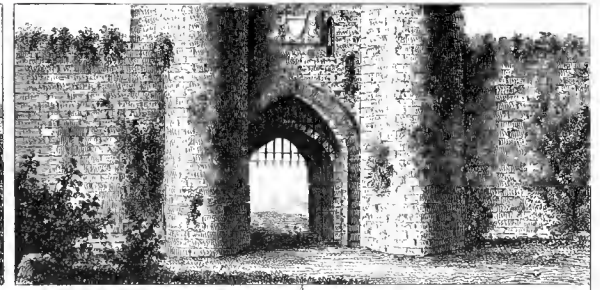
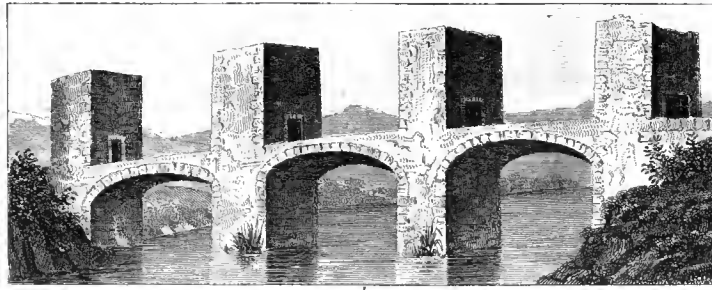
14

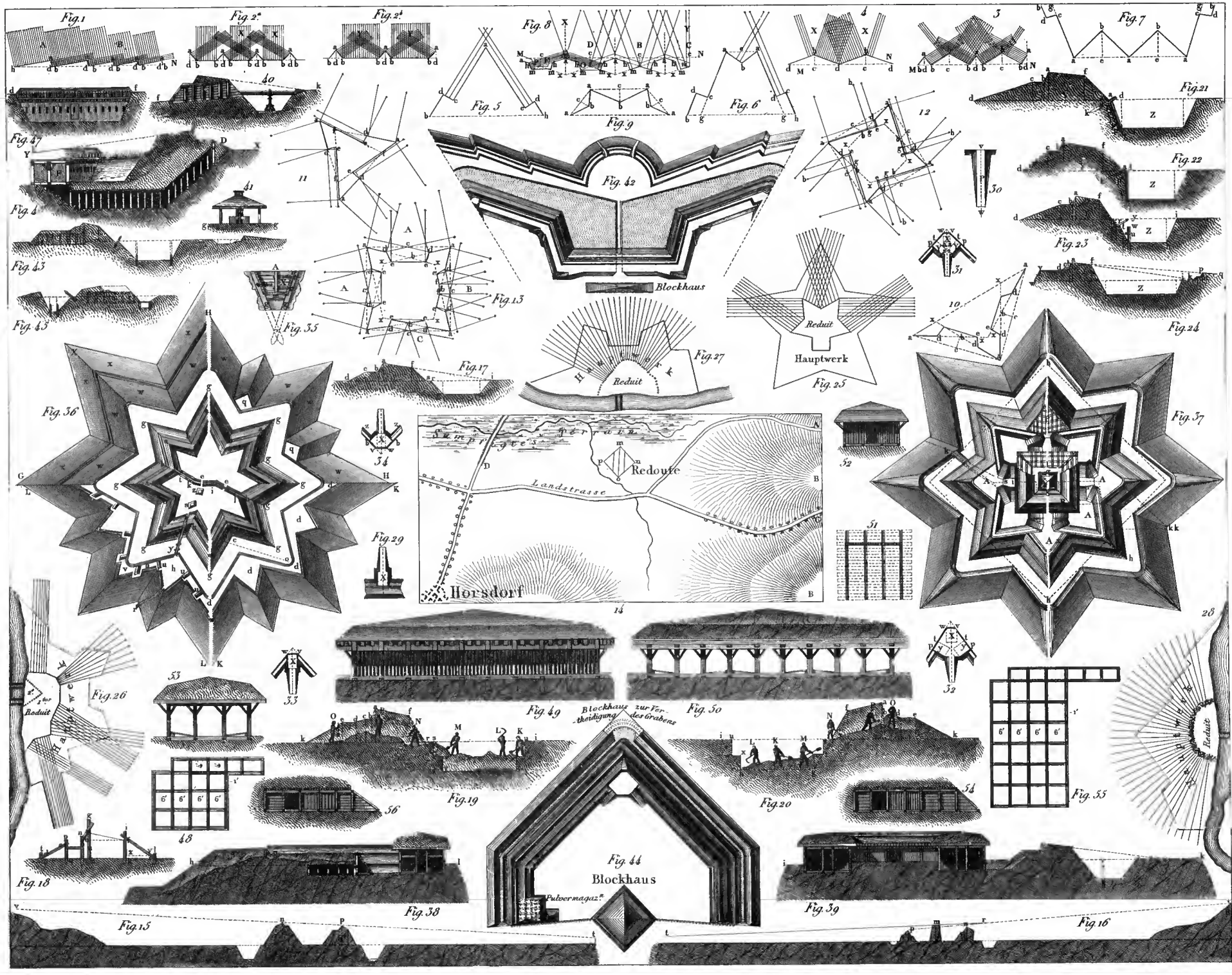
5

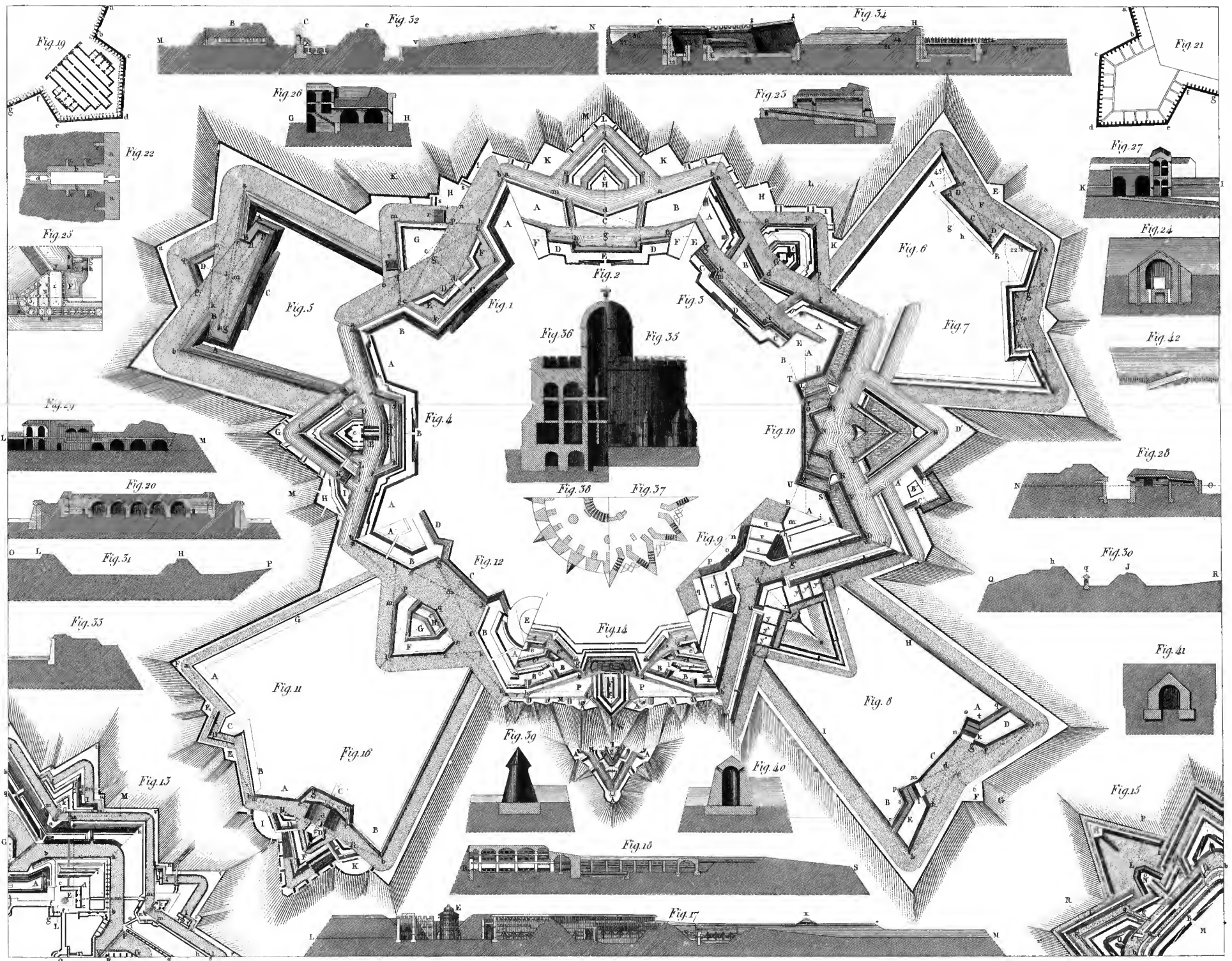
3

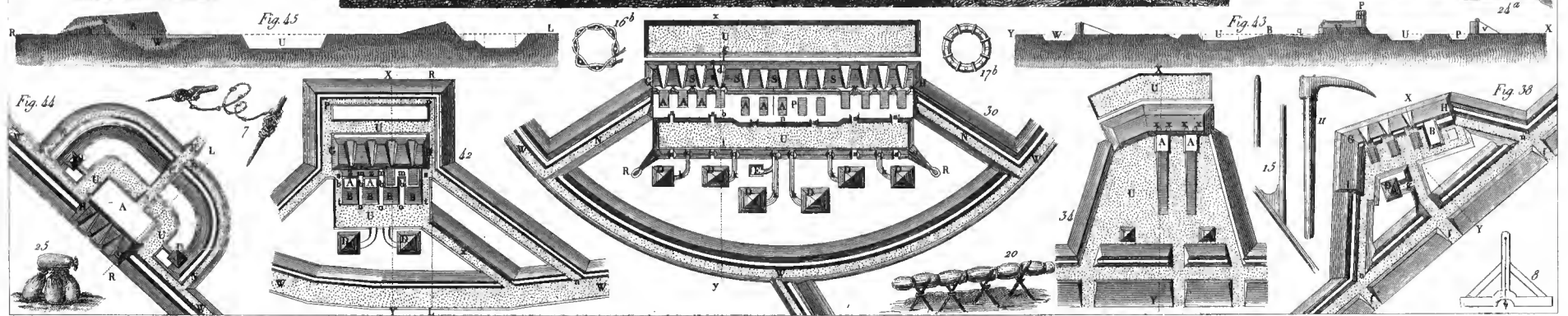
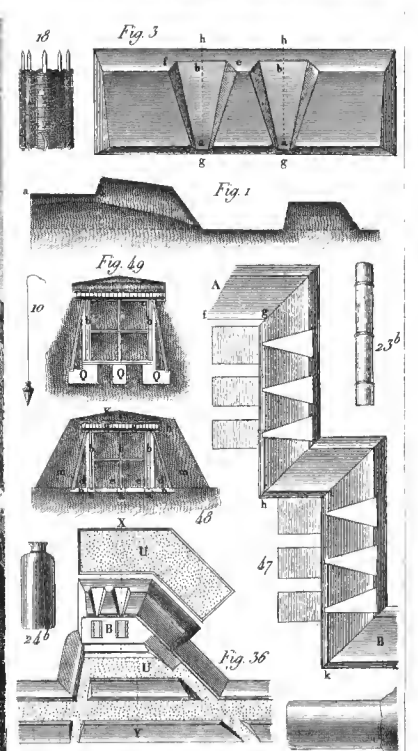
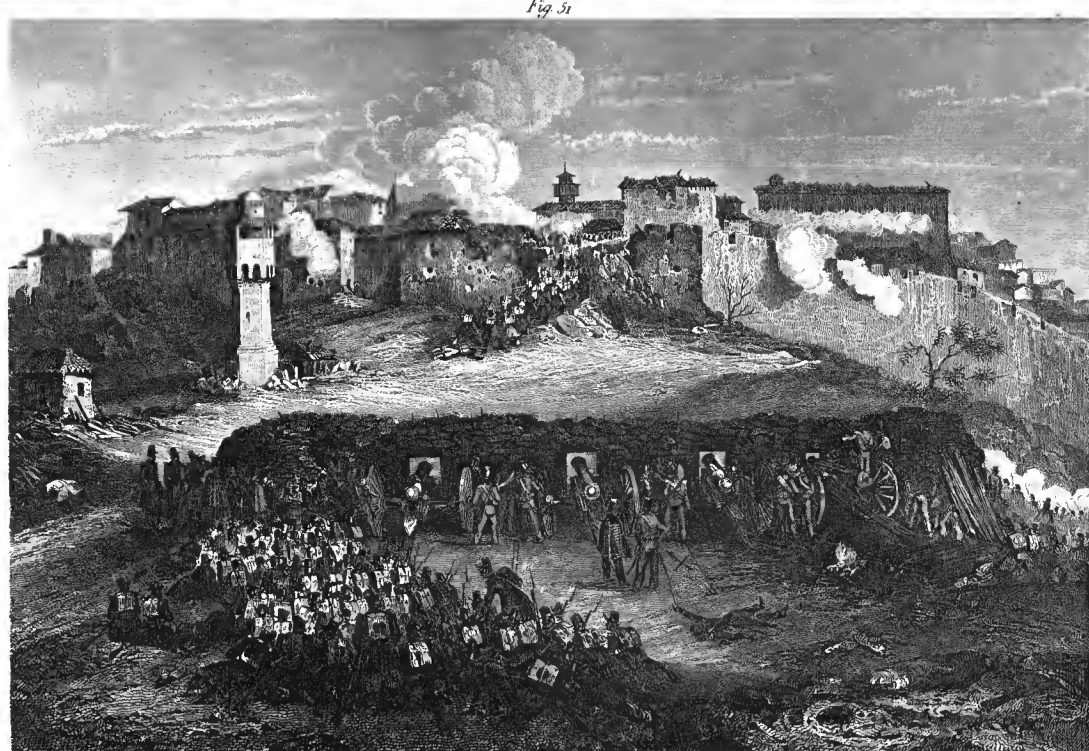
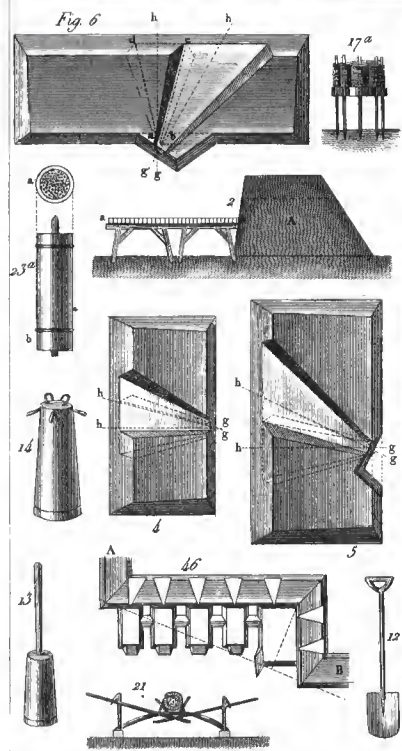
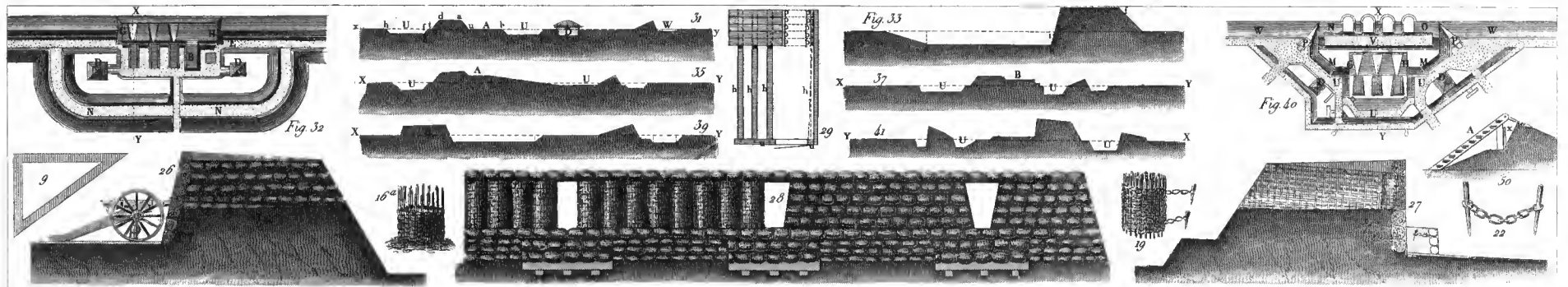
11

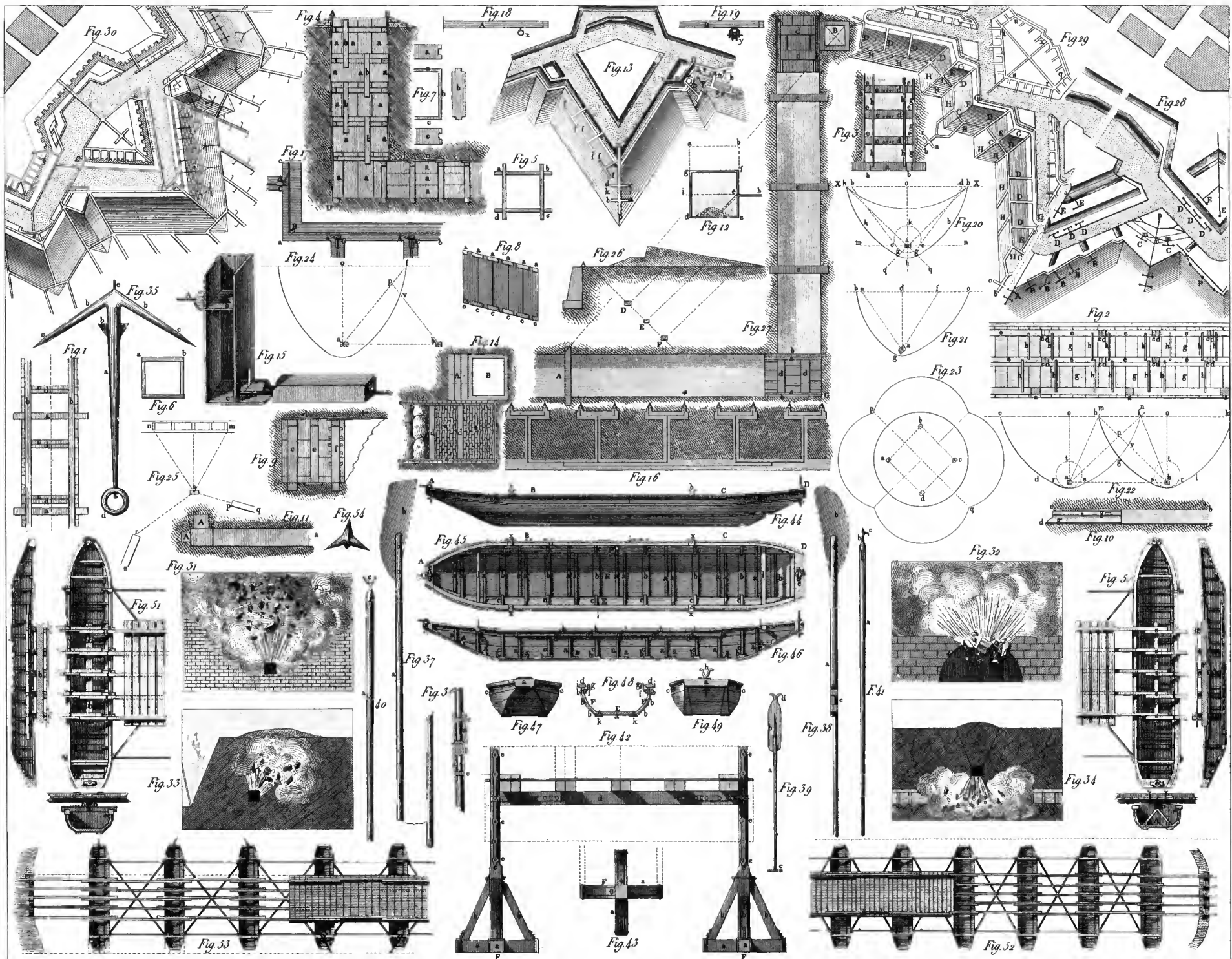















ICONOGRAPHIC
E N C Y C L O P Æ D I A .

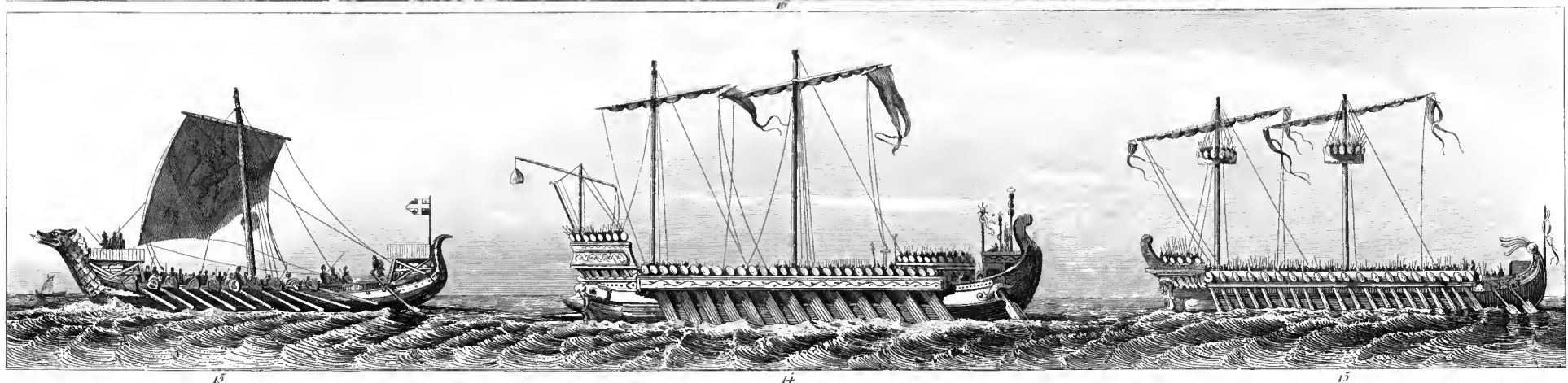
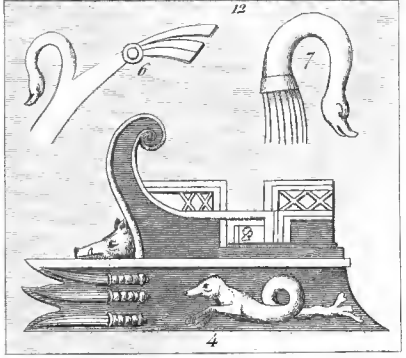
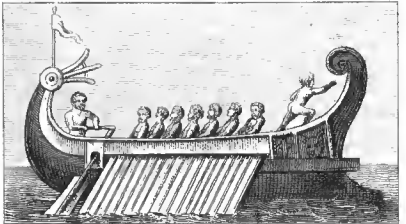
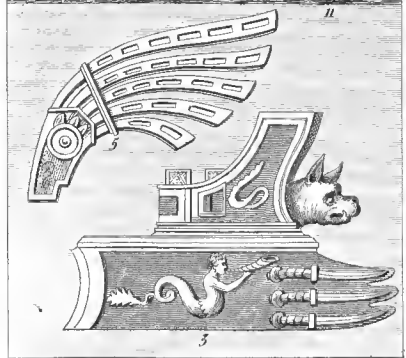
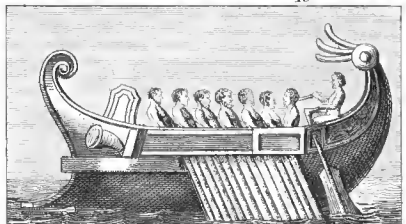
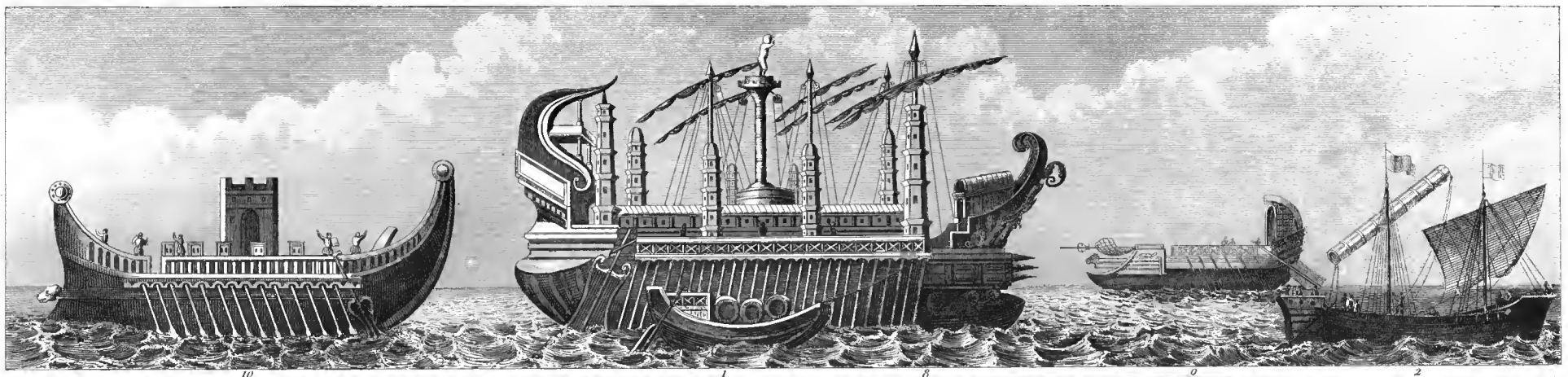
DIVISION VI.

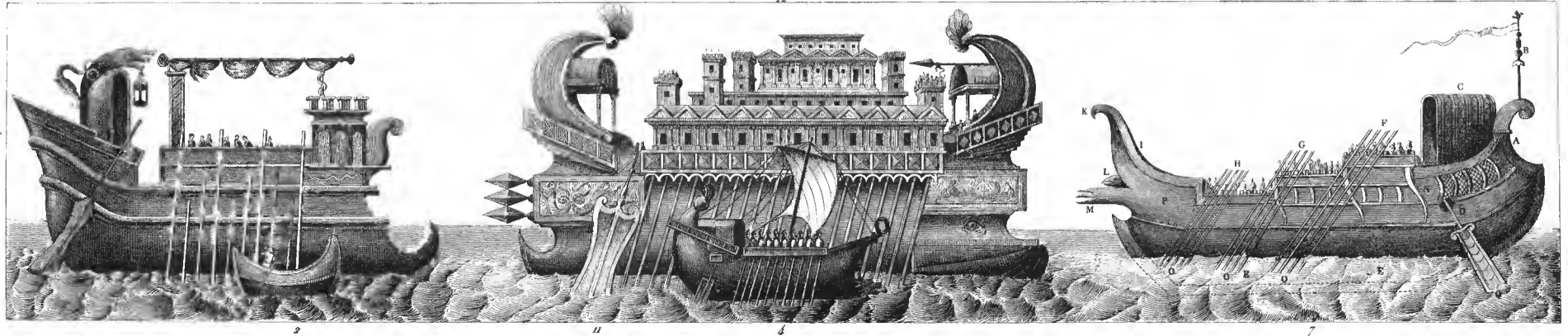
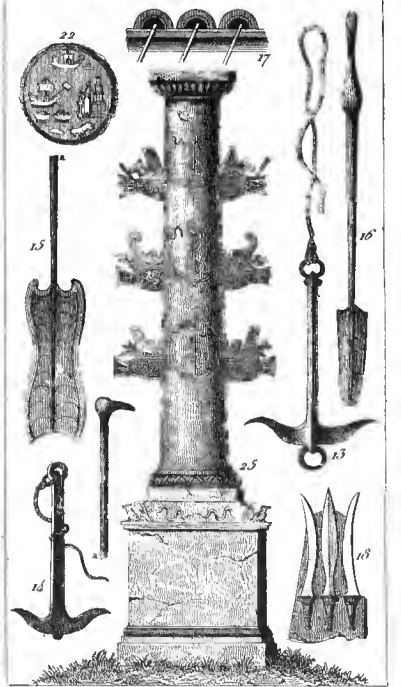
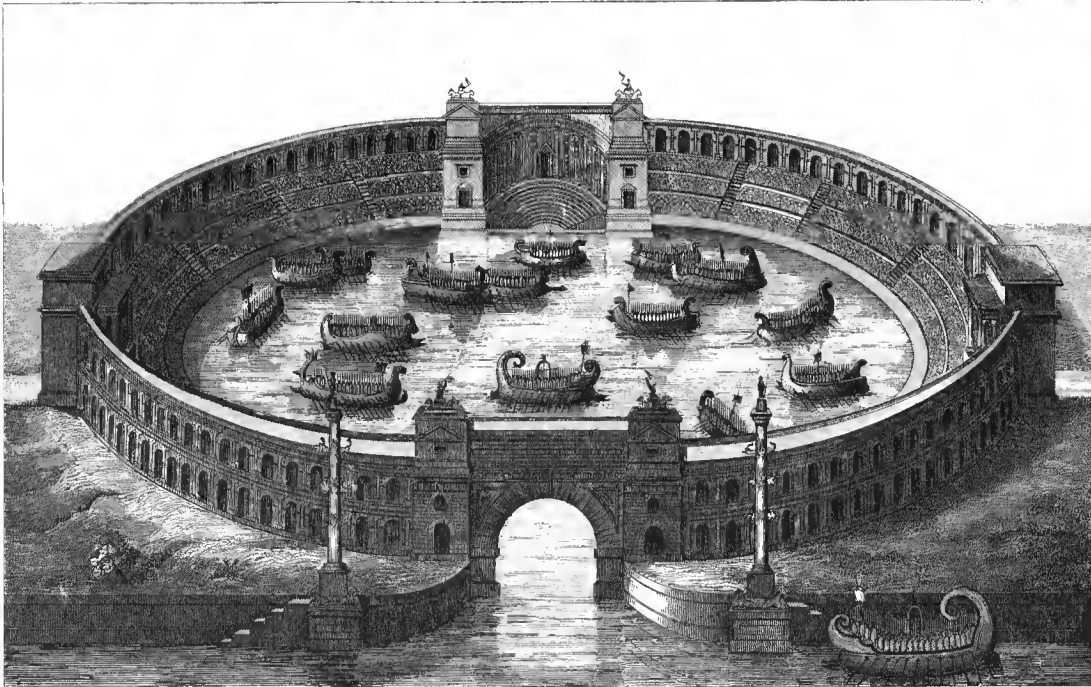
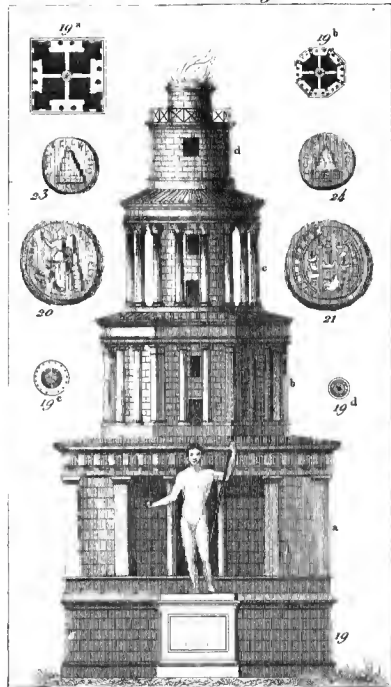
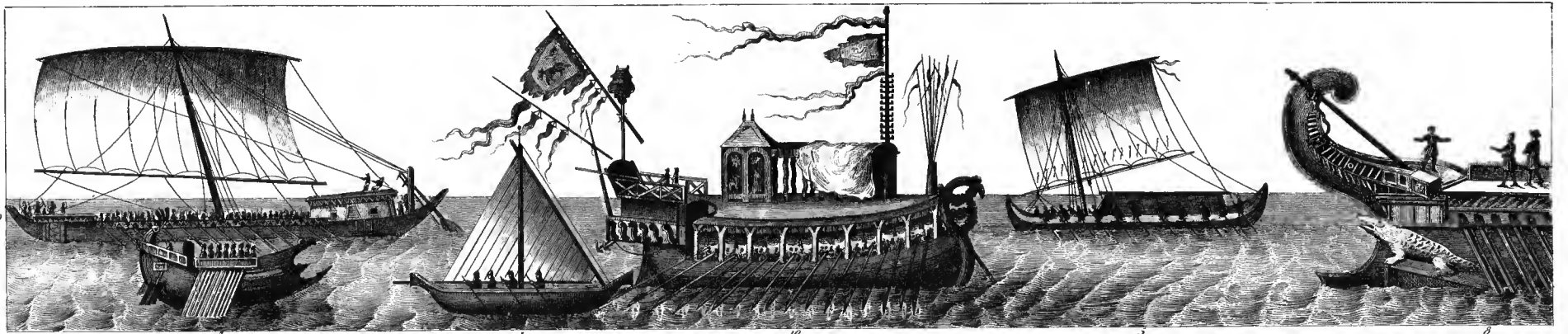
NAVAL SCIENCES.

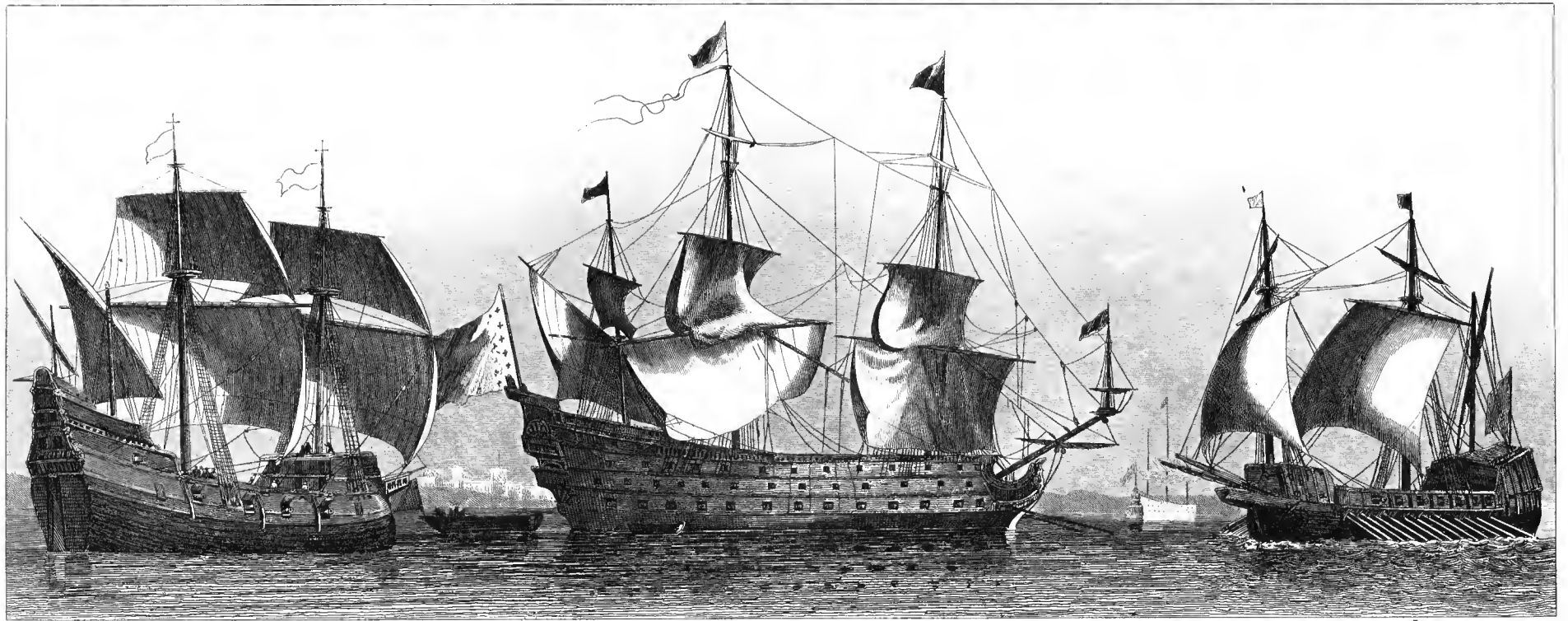
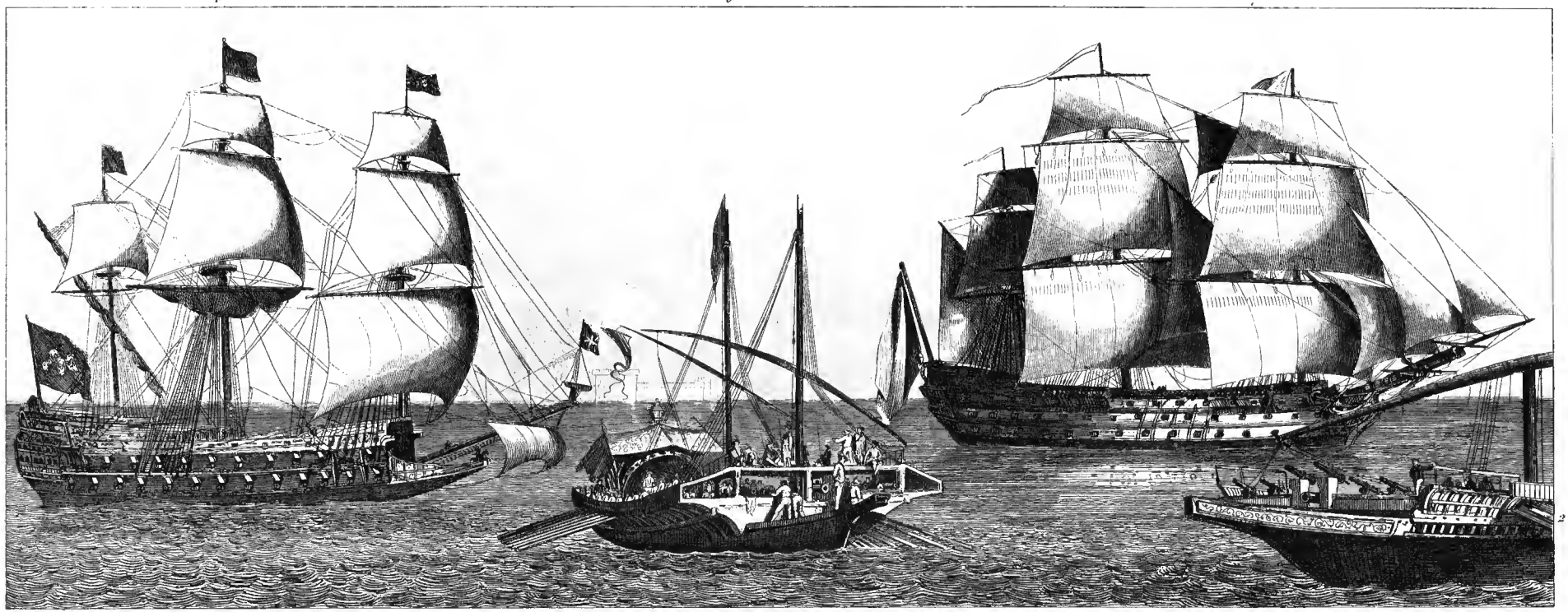
THIRTY-TWO PLATES.

NEW YORK: 1851.
PUBLISHED BY RUDOLPH GARRIGUE,
2 BARCLAY STREET (ASTOR HOUSE).





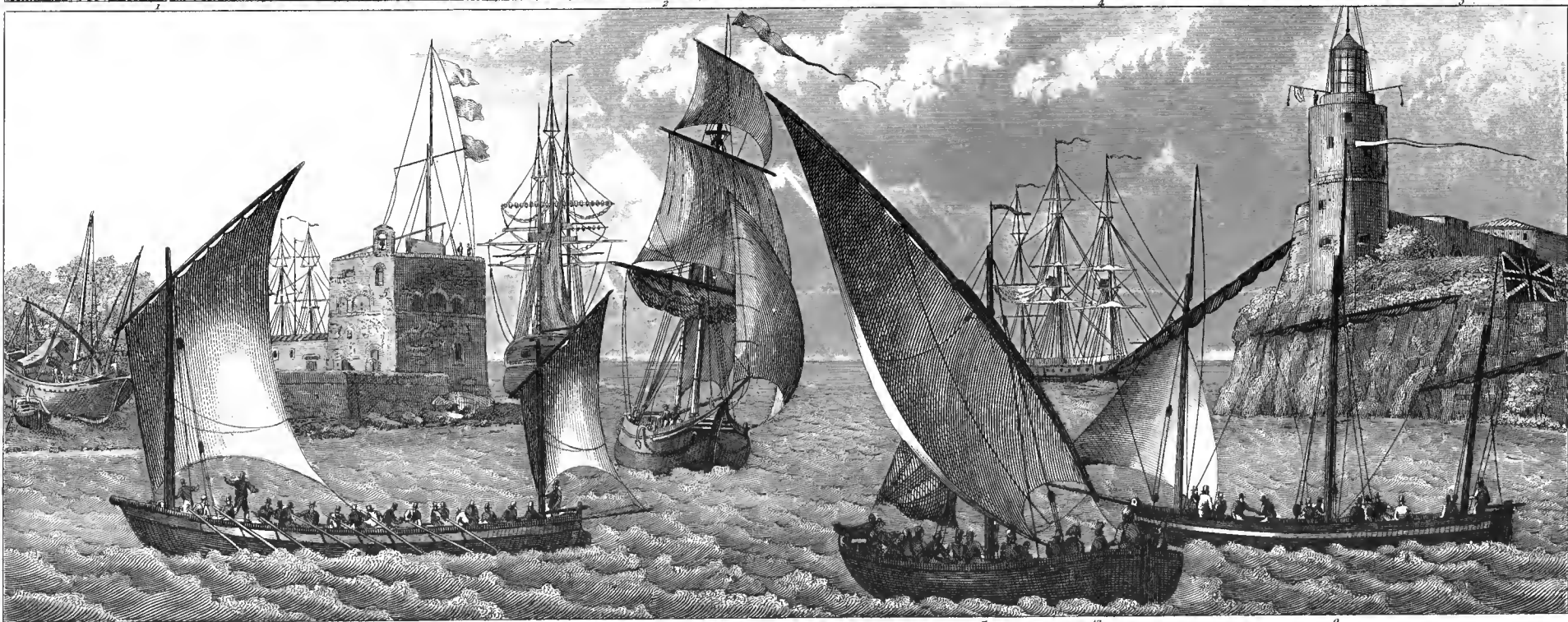
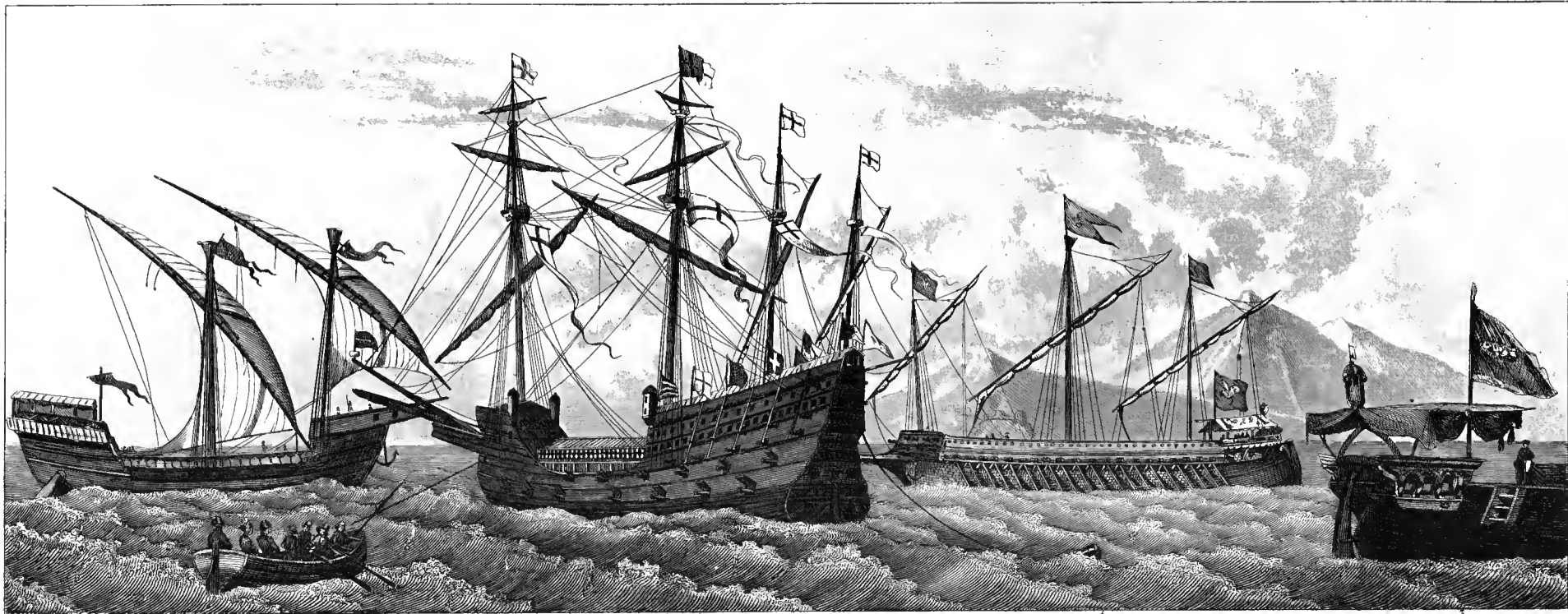


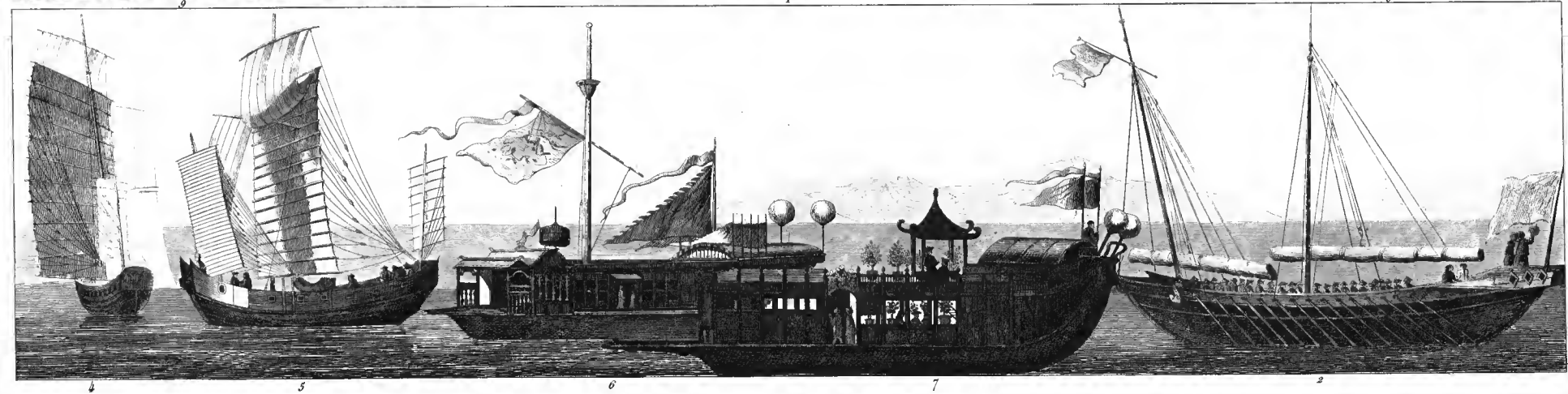
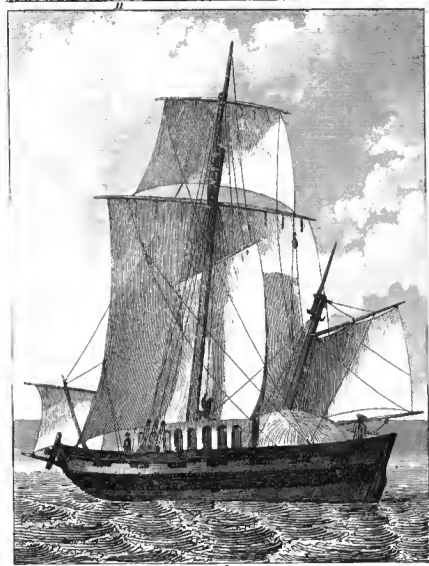
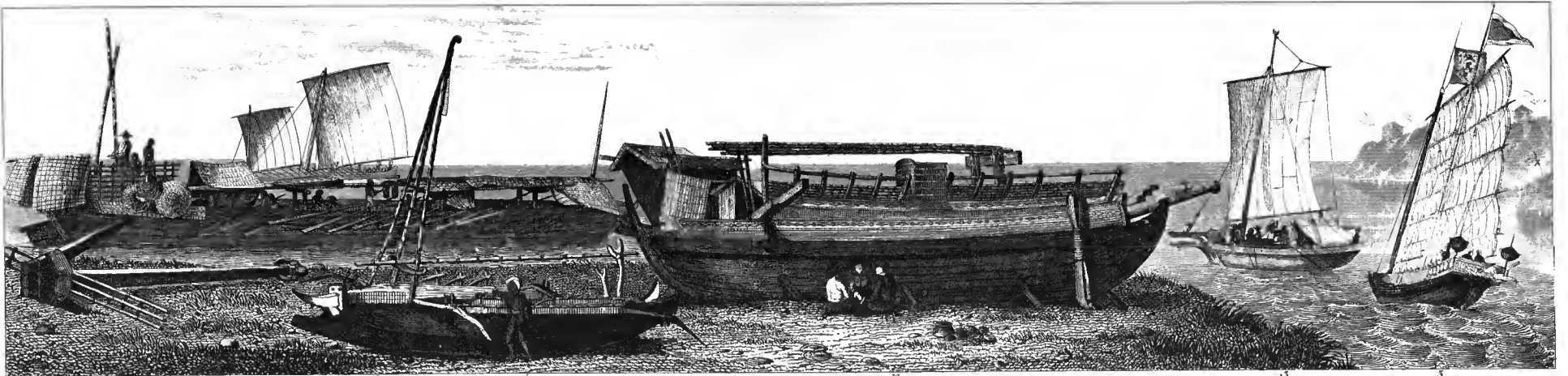


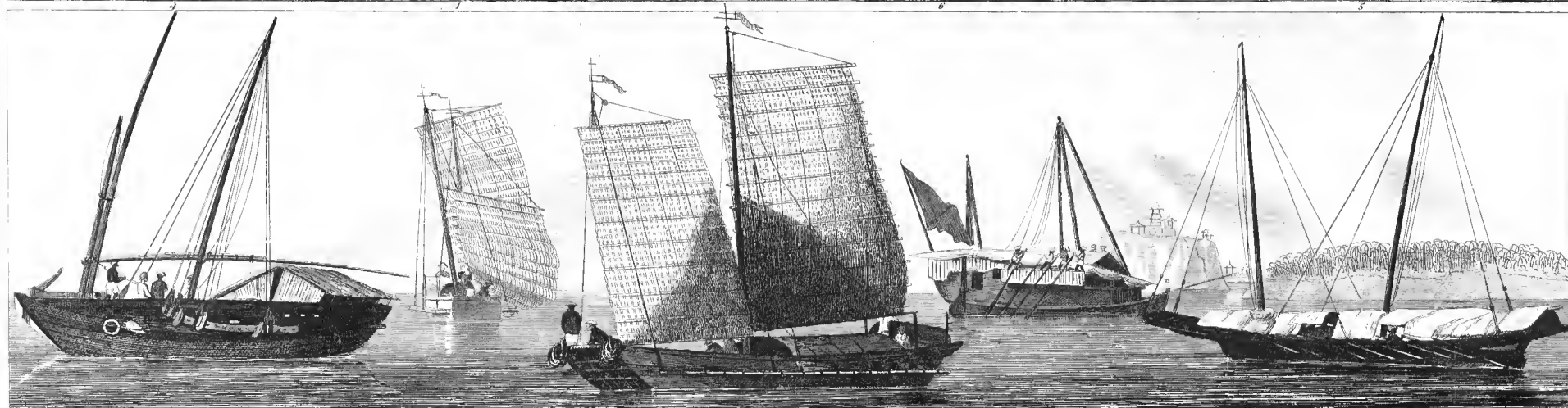
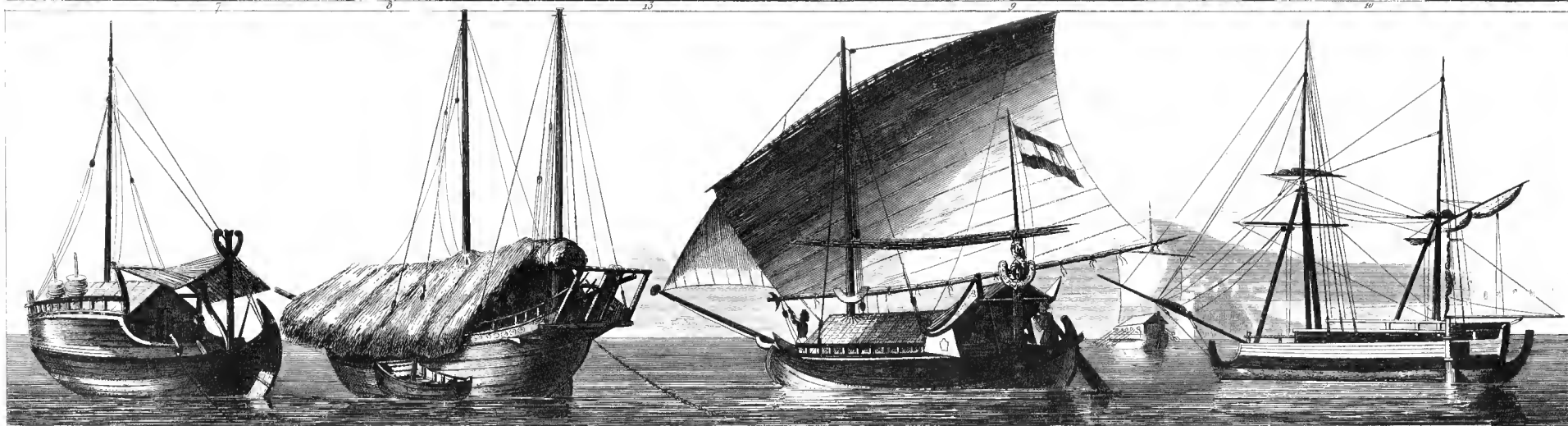
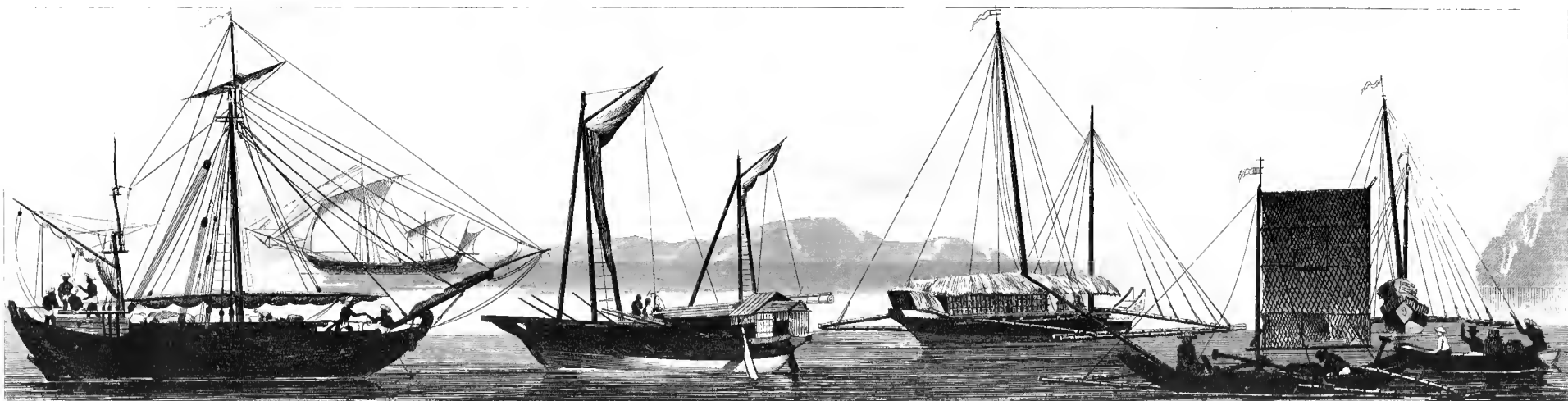
1

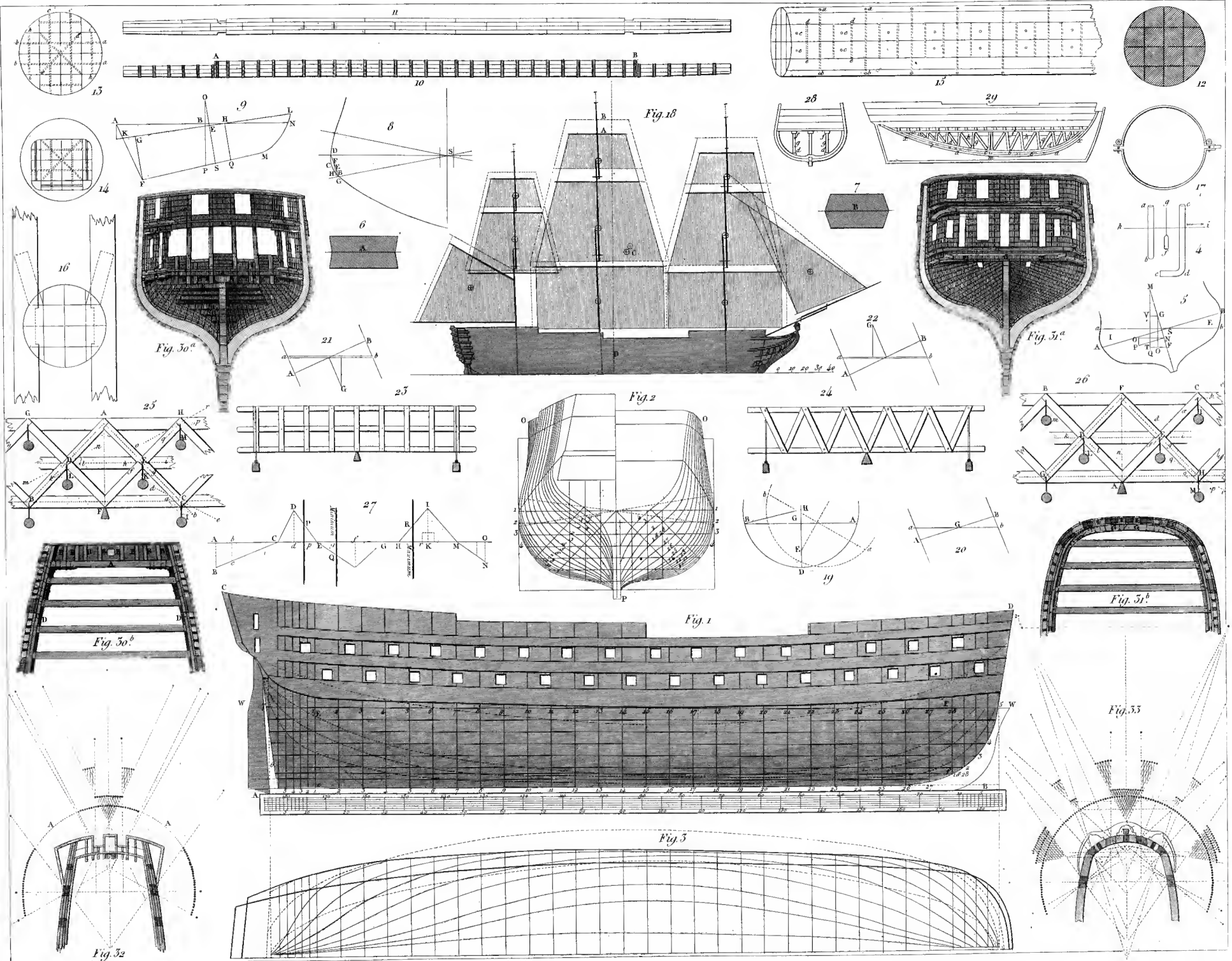
5

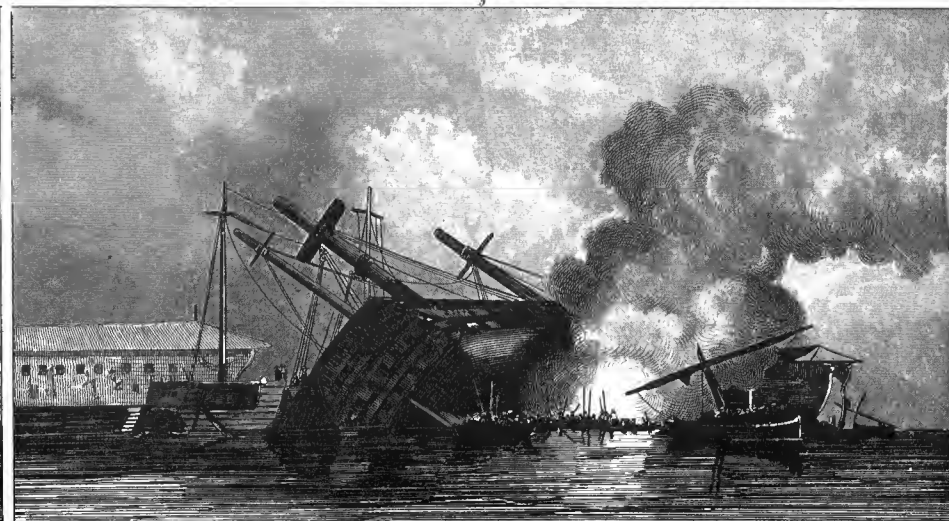
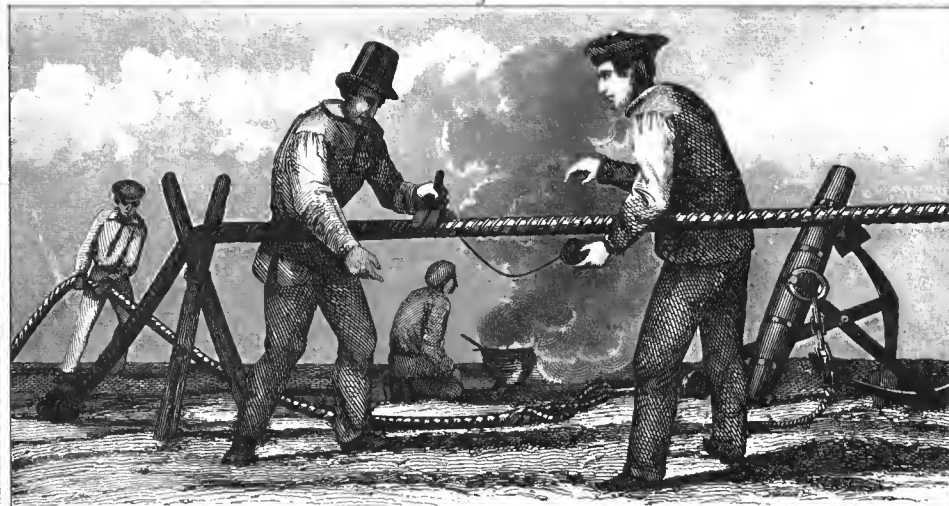
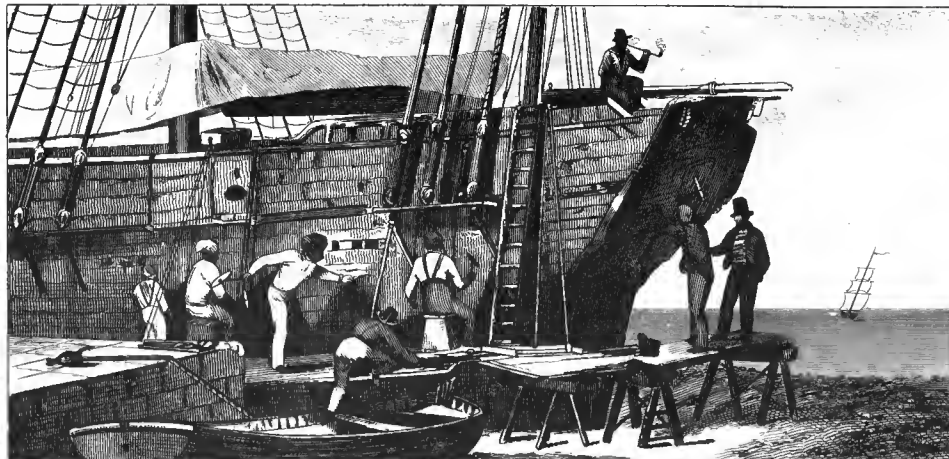
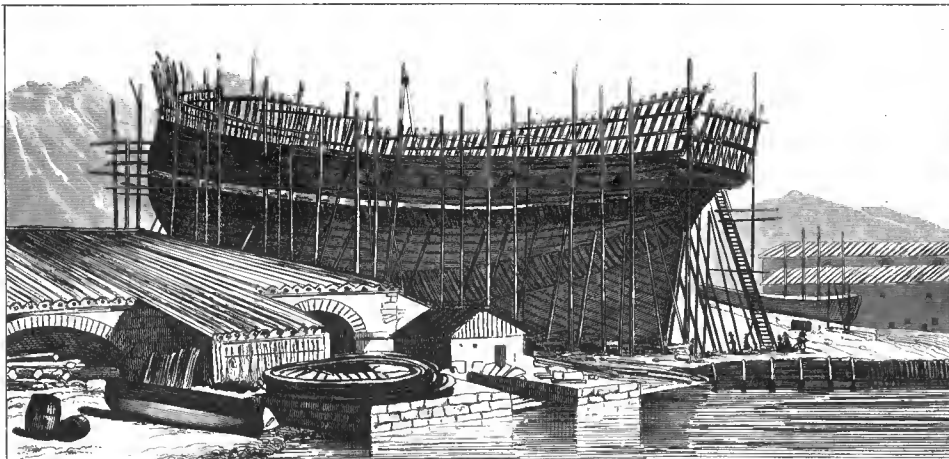
3

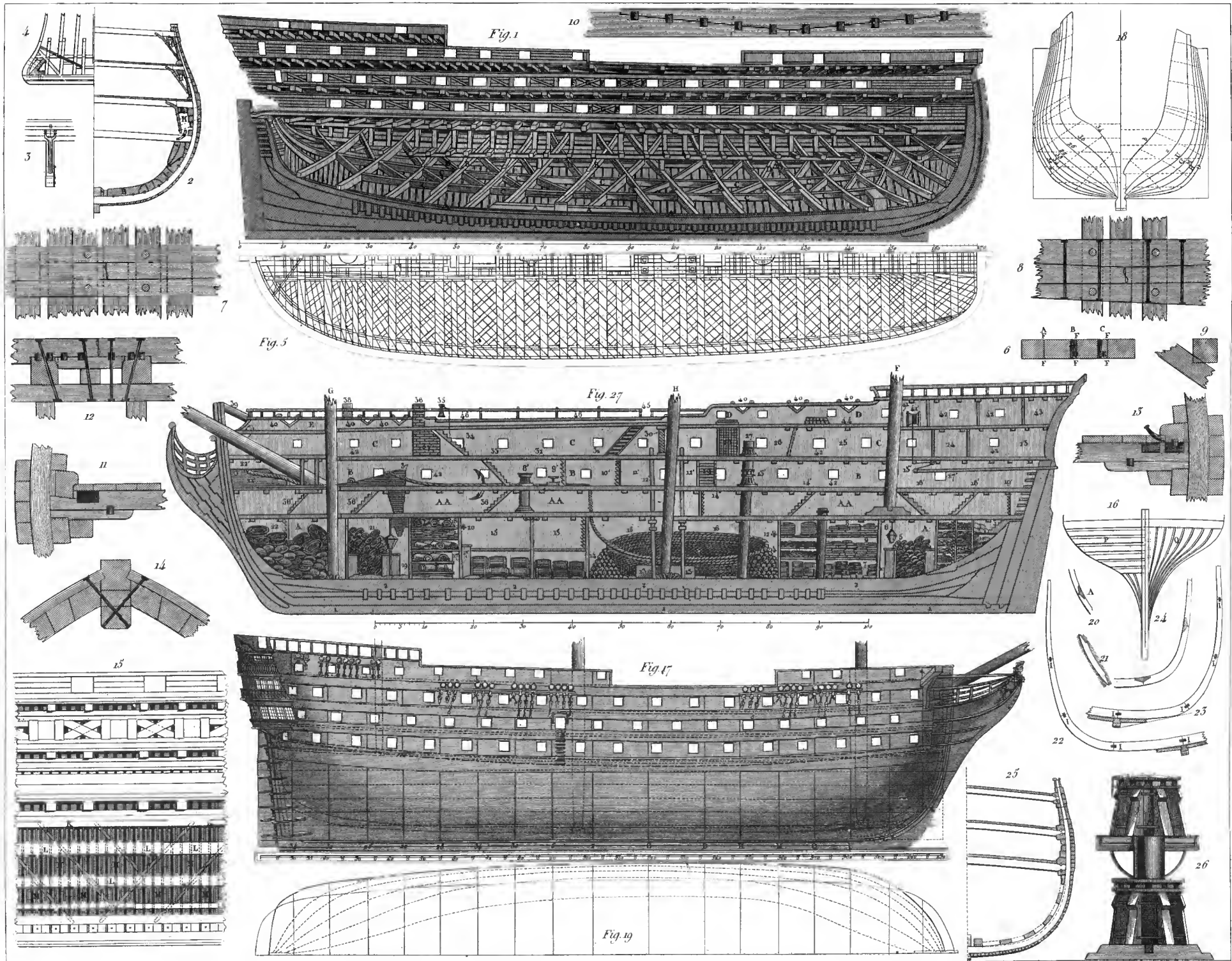


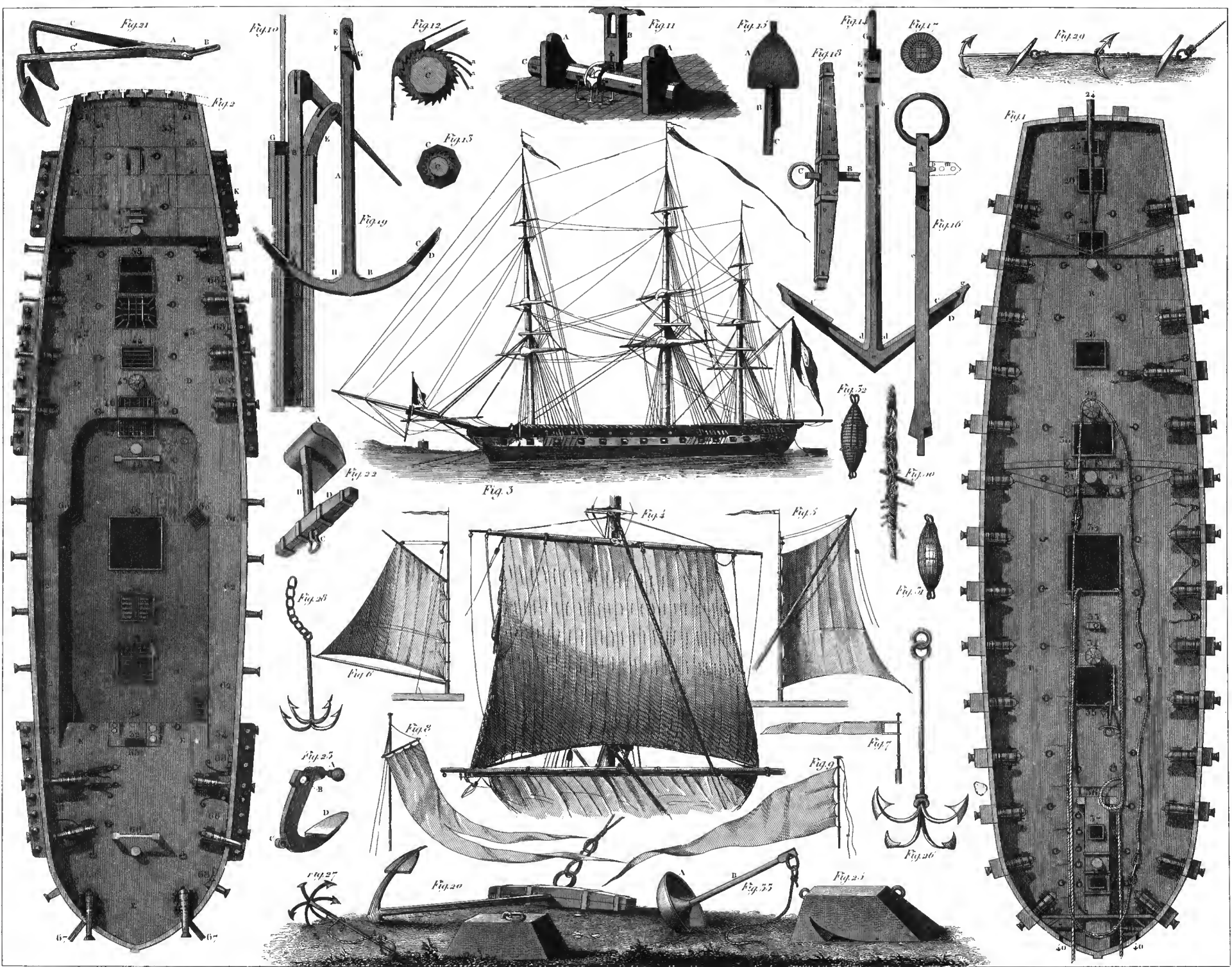












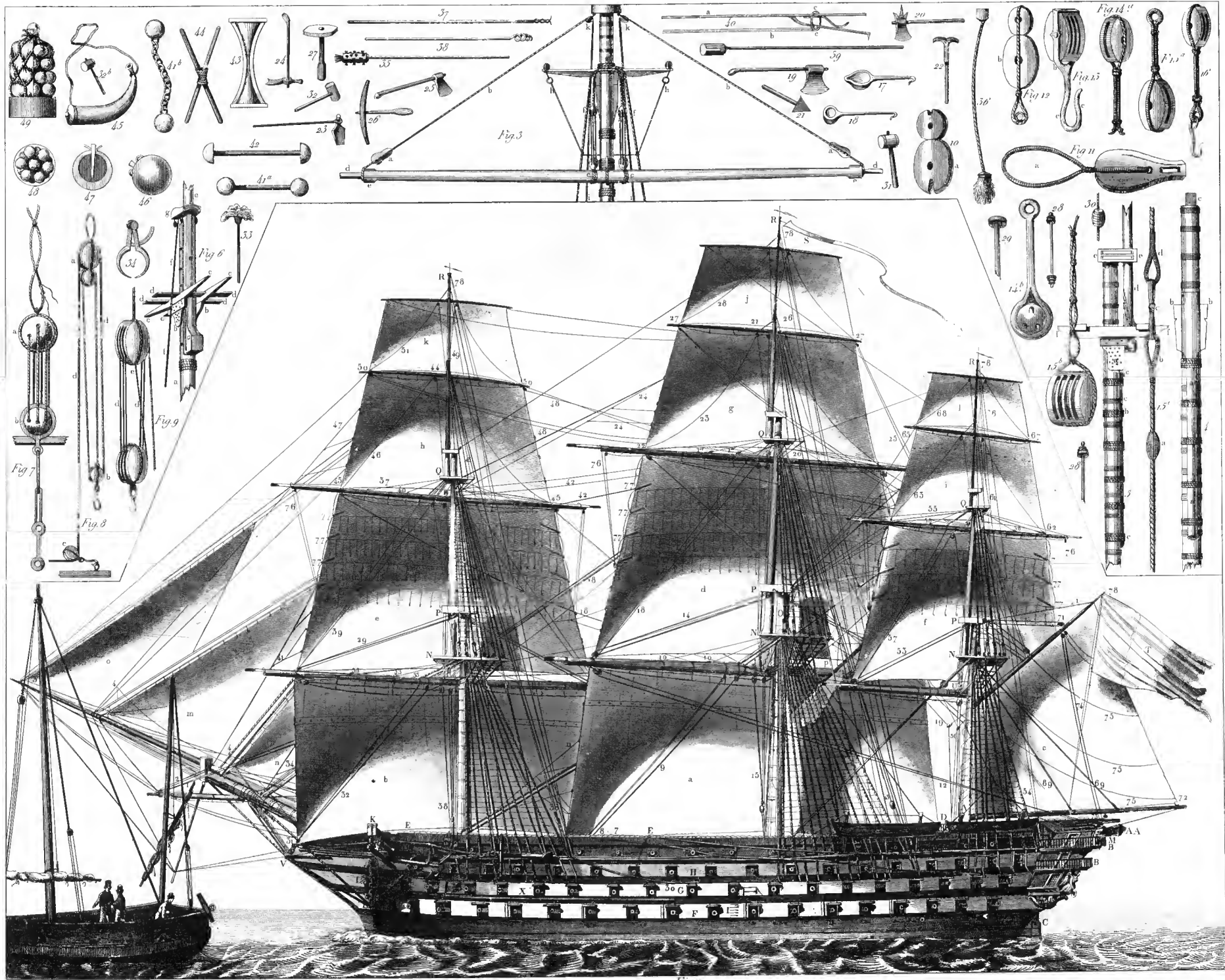
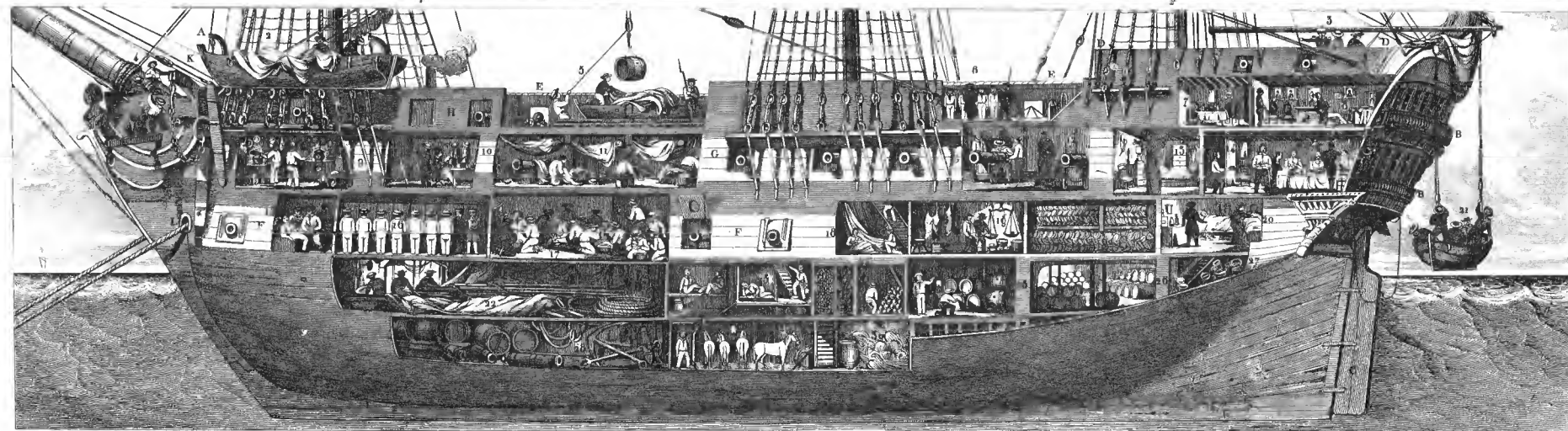
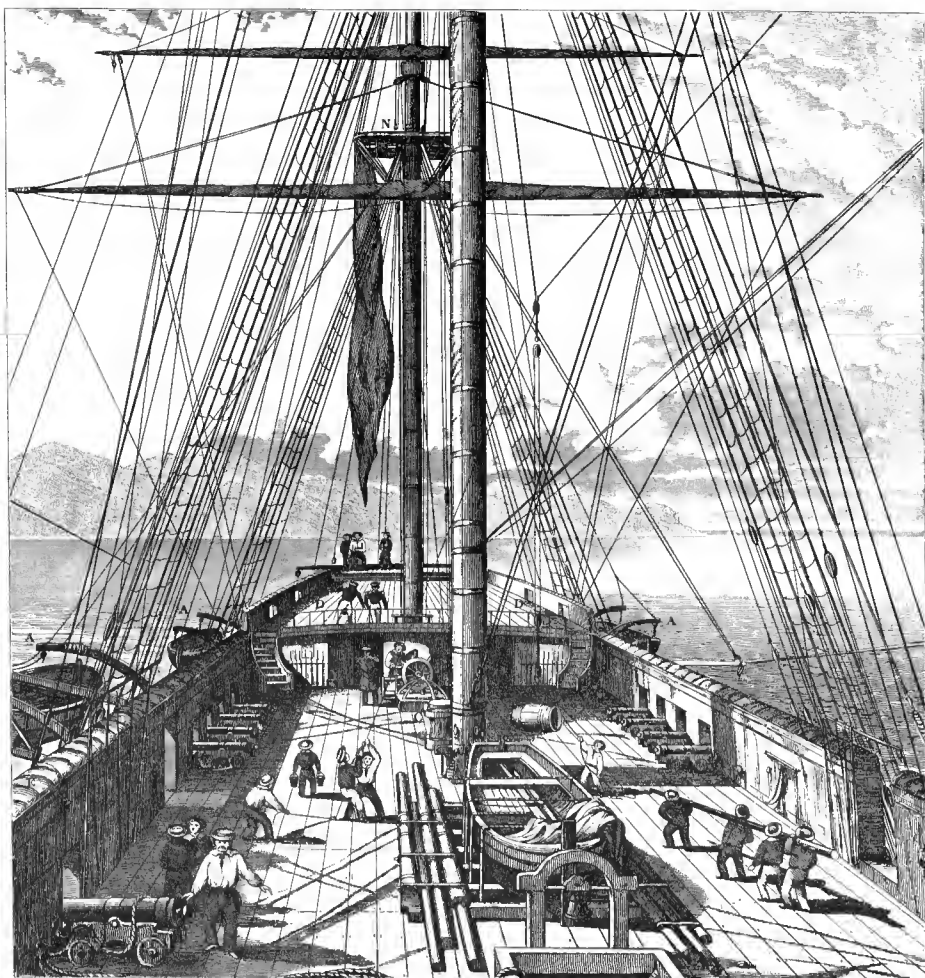
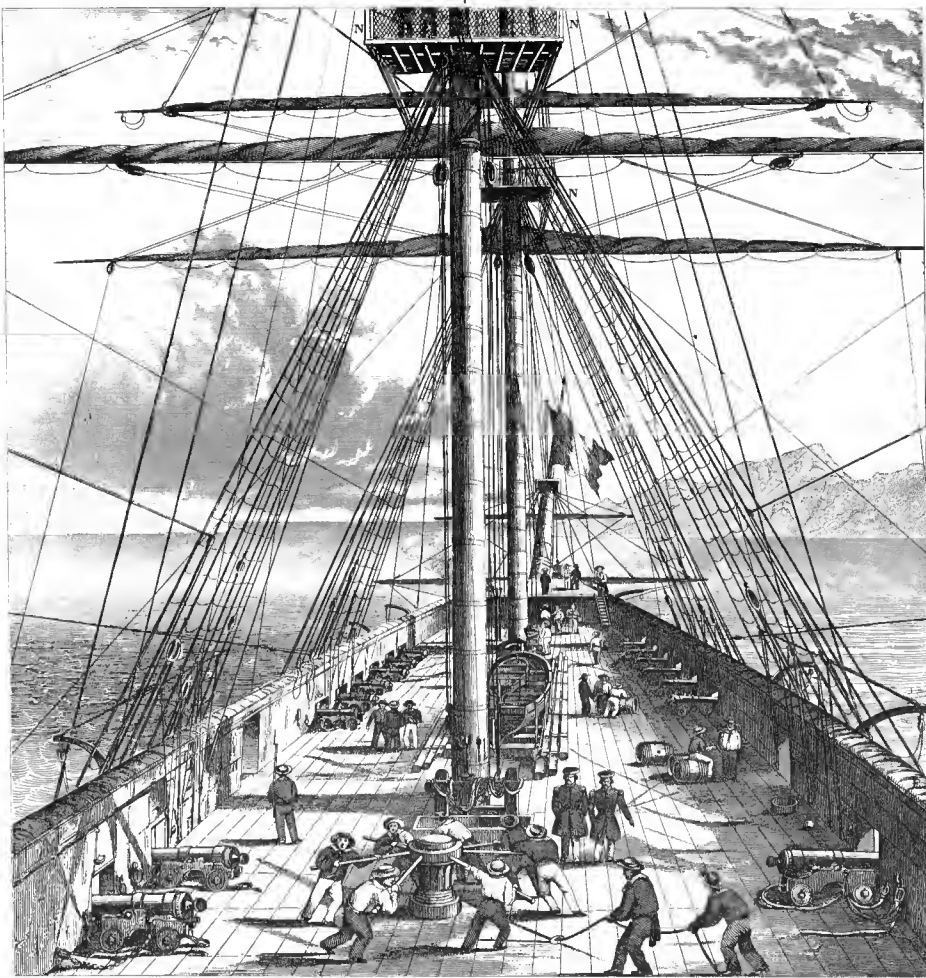
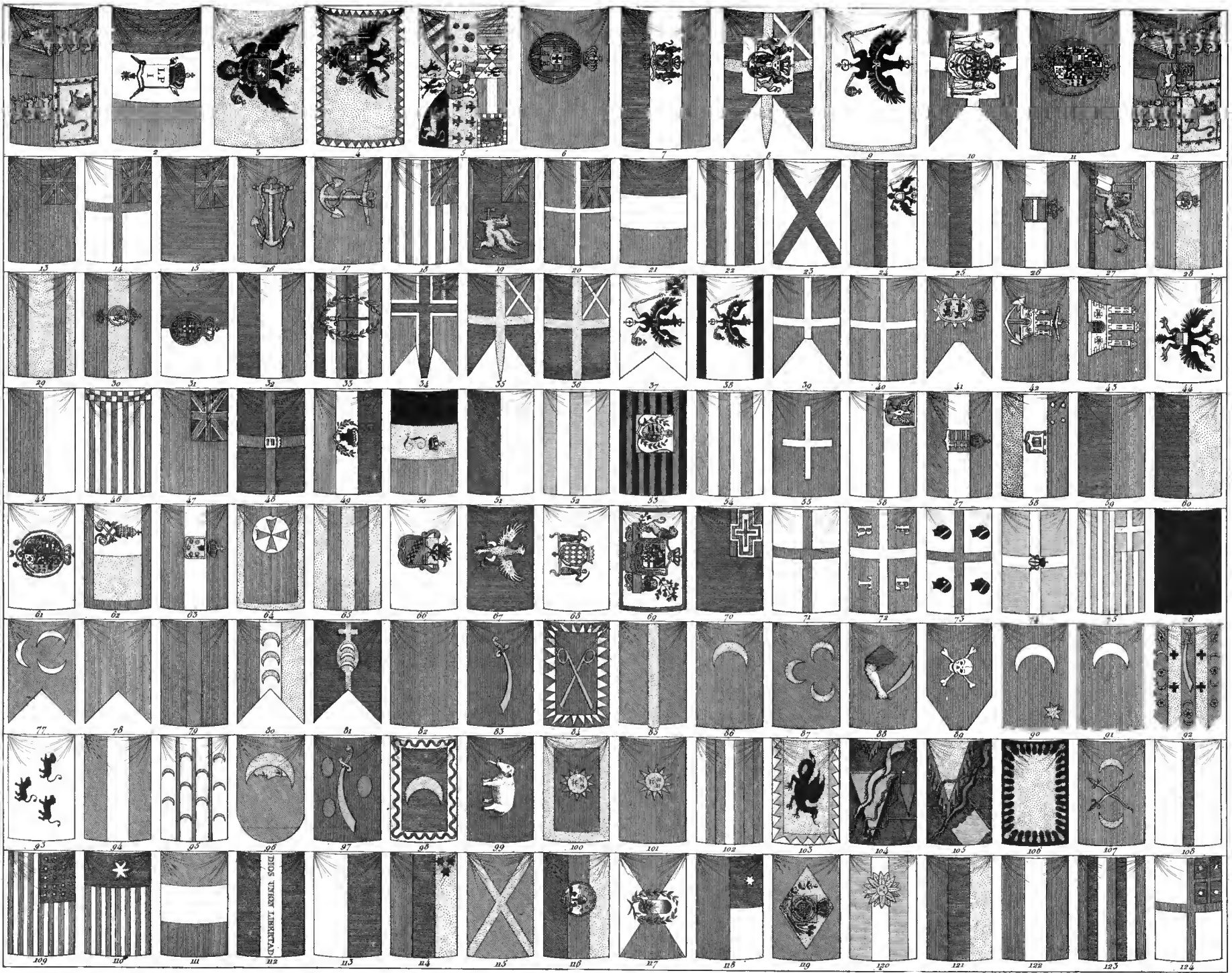


Fig. 1





v. Heck d. r.

Gelb

Koth

Hellblau

Dunkelblau

Schwarz

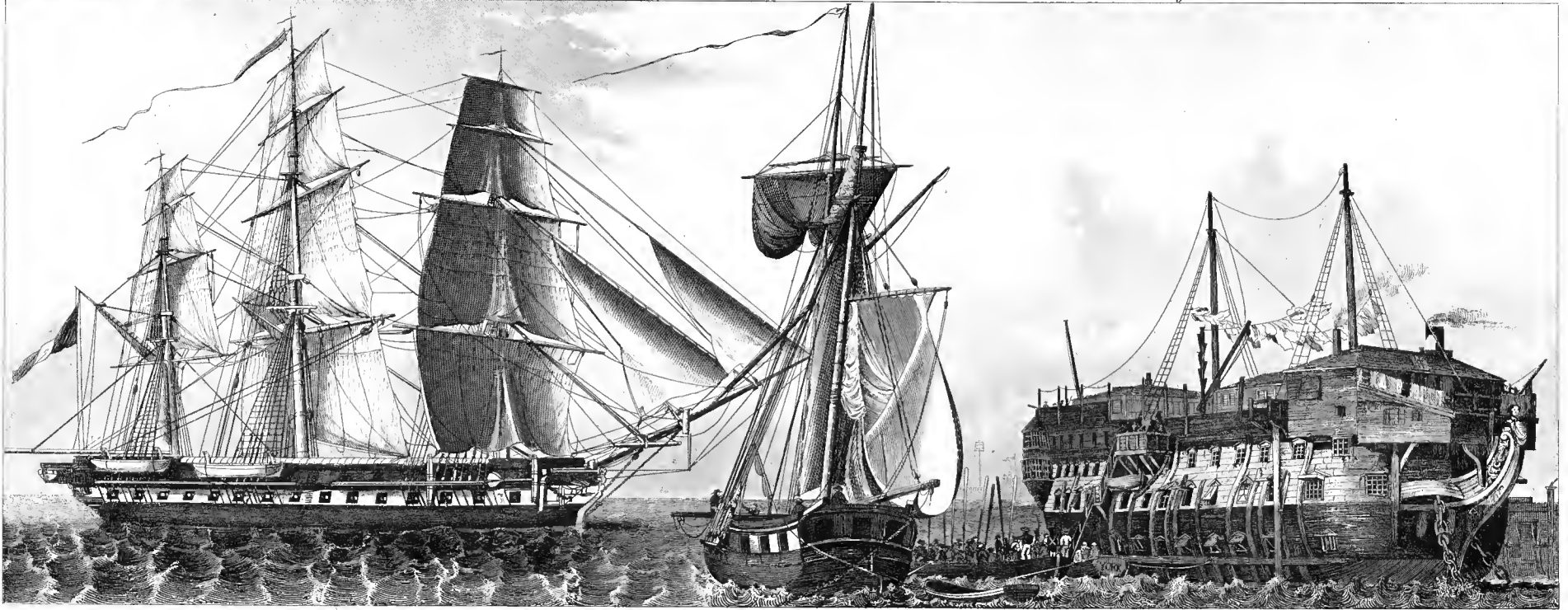
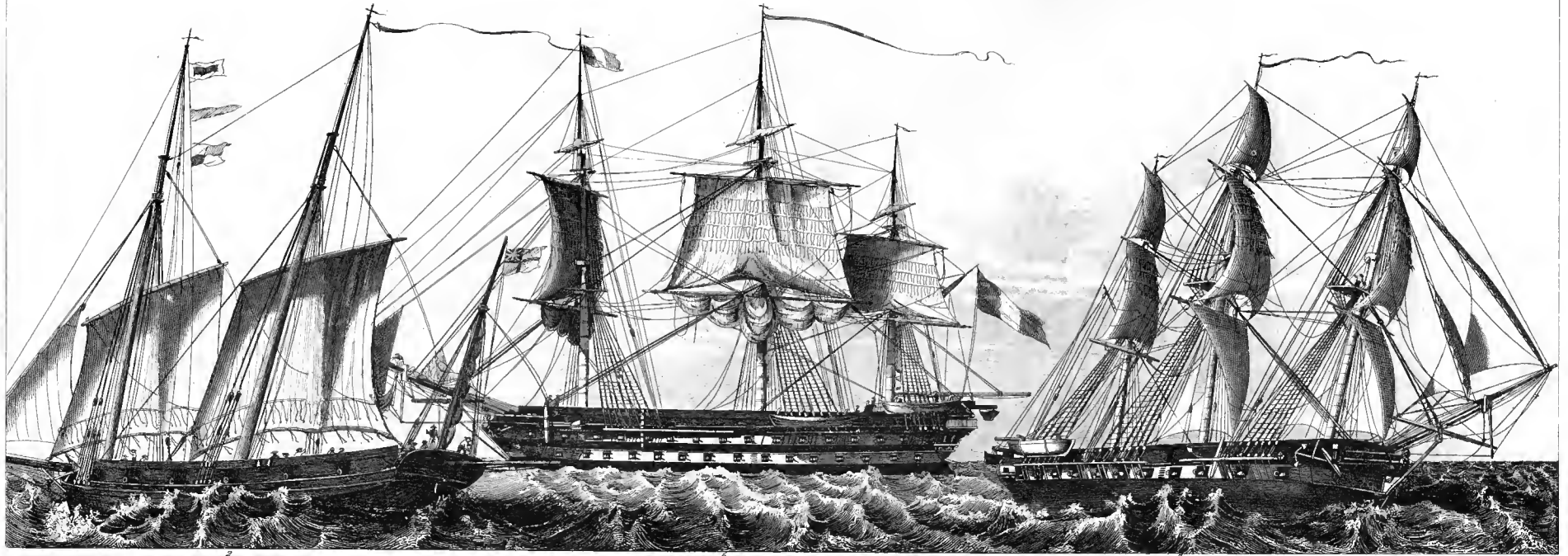
Hellgrün

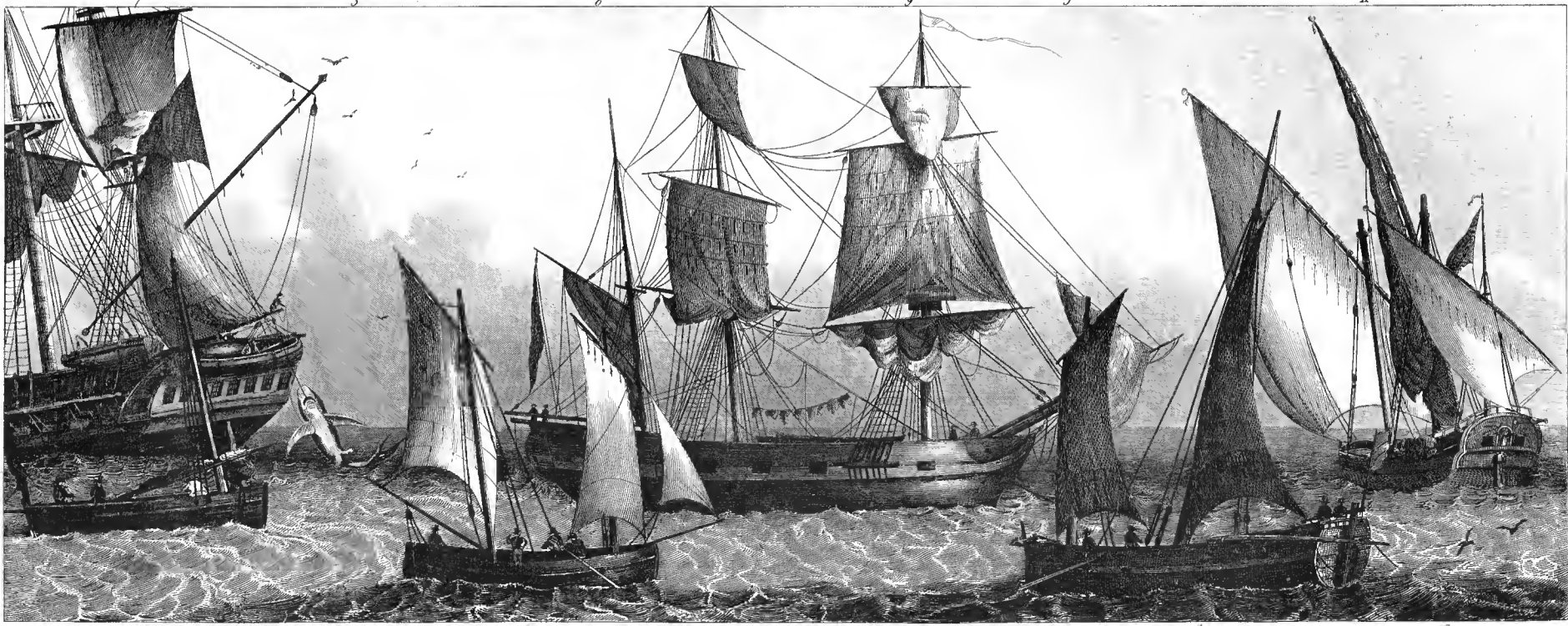
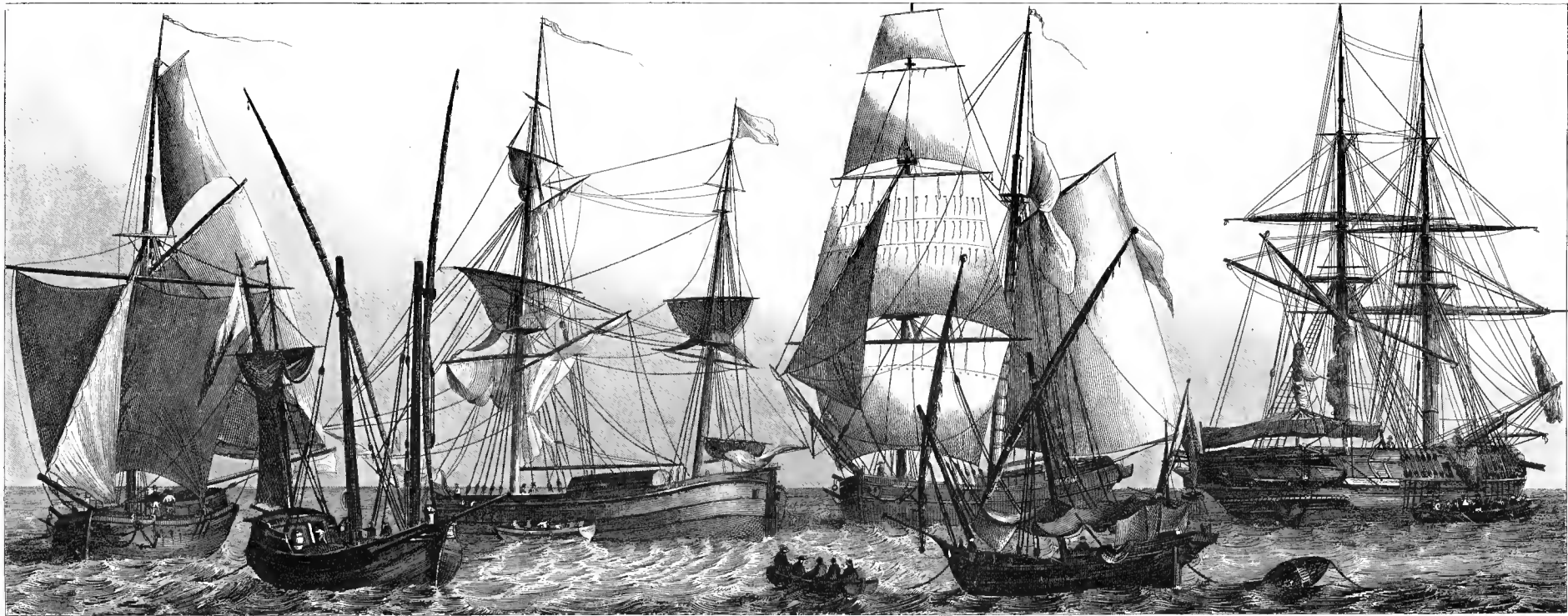
Dunkelgrün

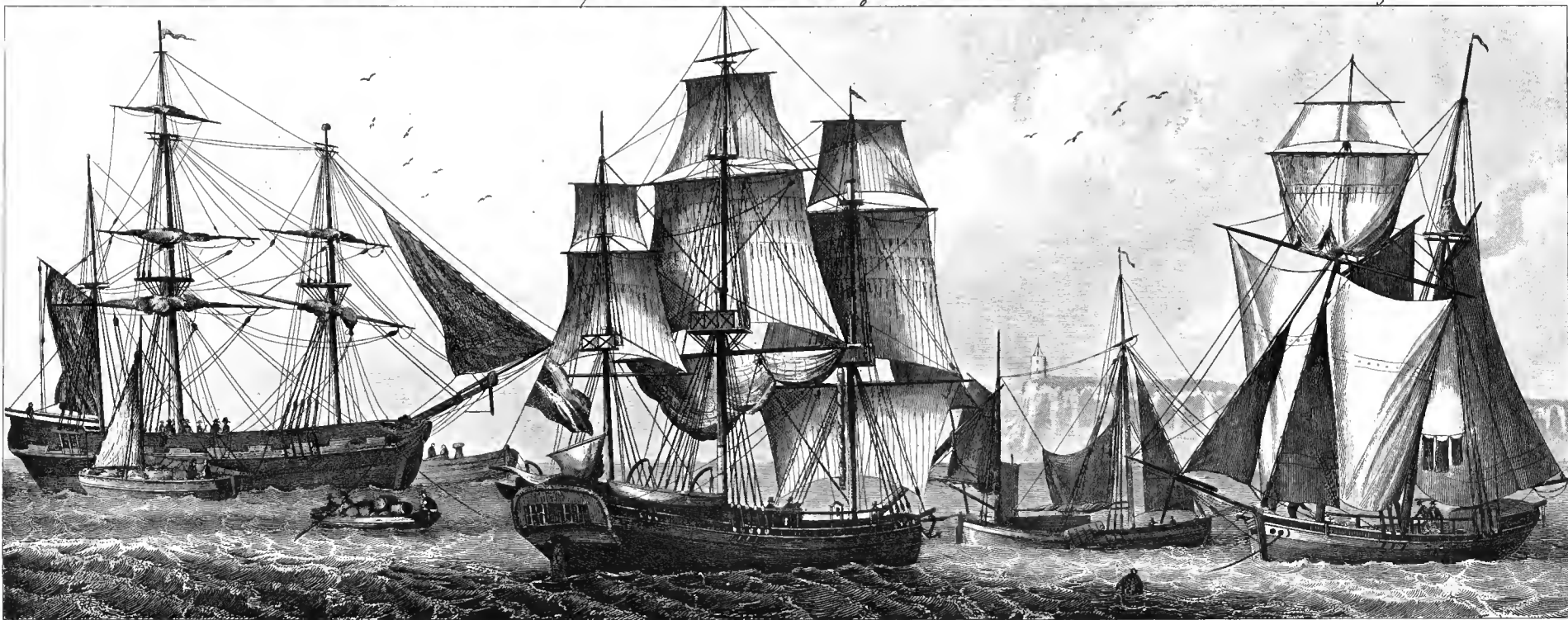
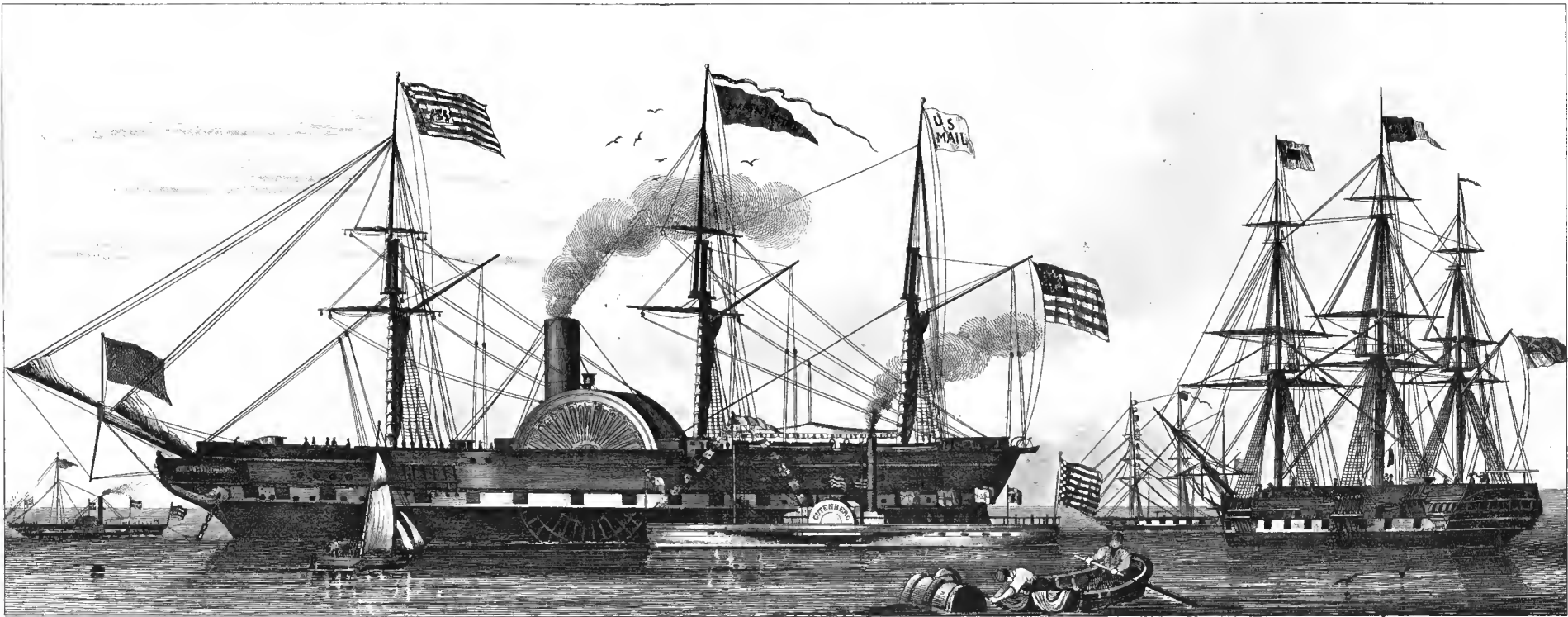
Purpur

Braun

Feldweg sculp





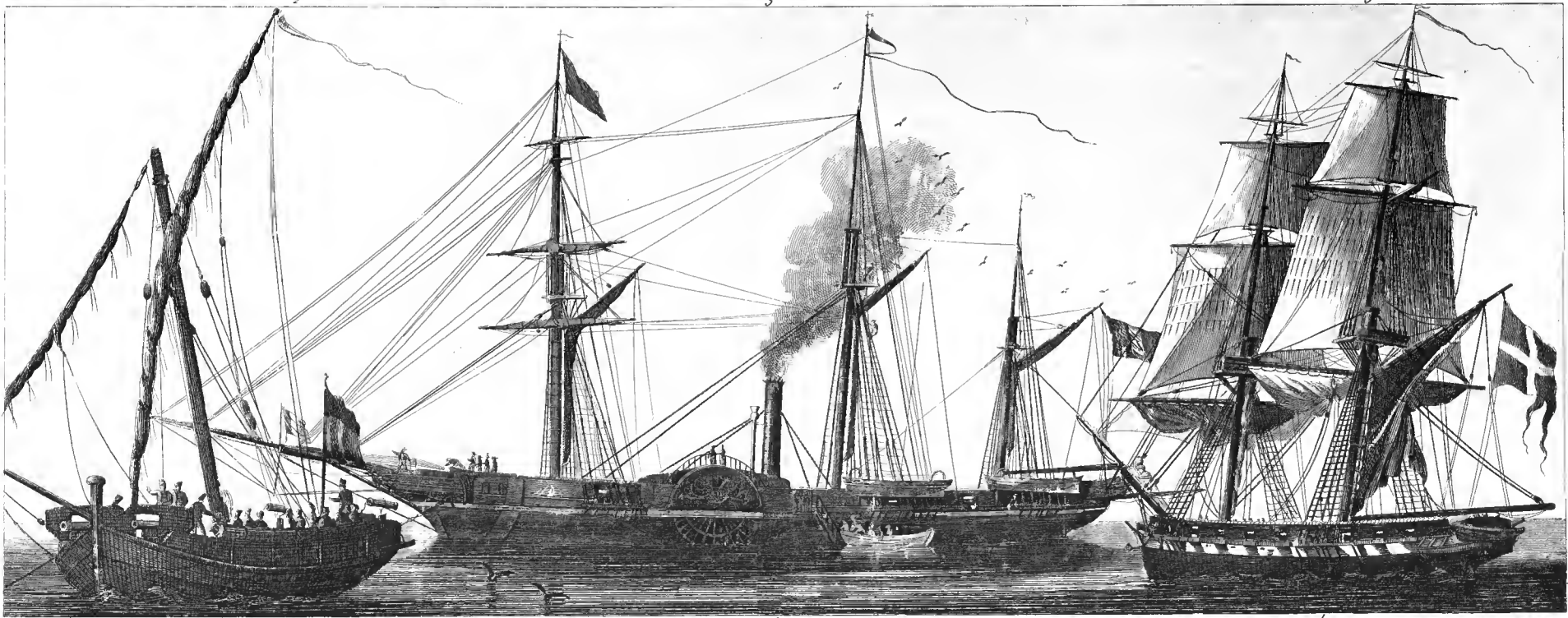
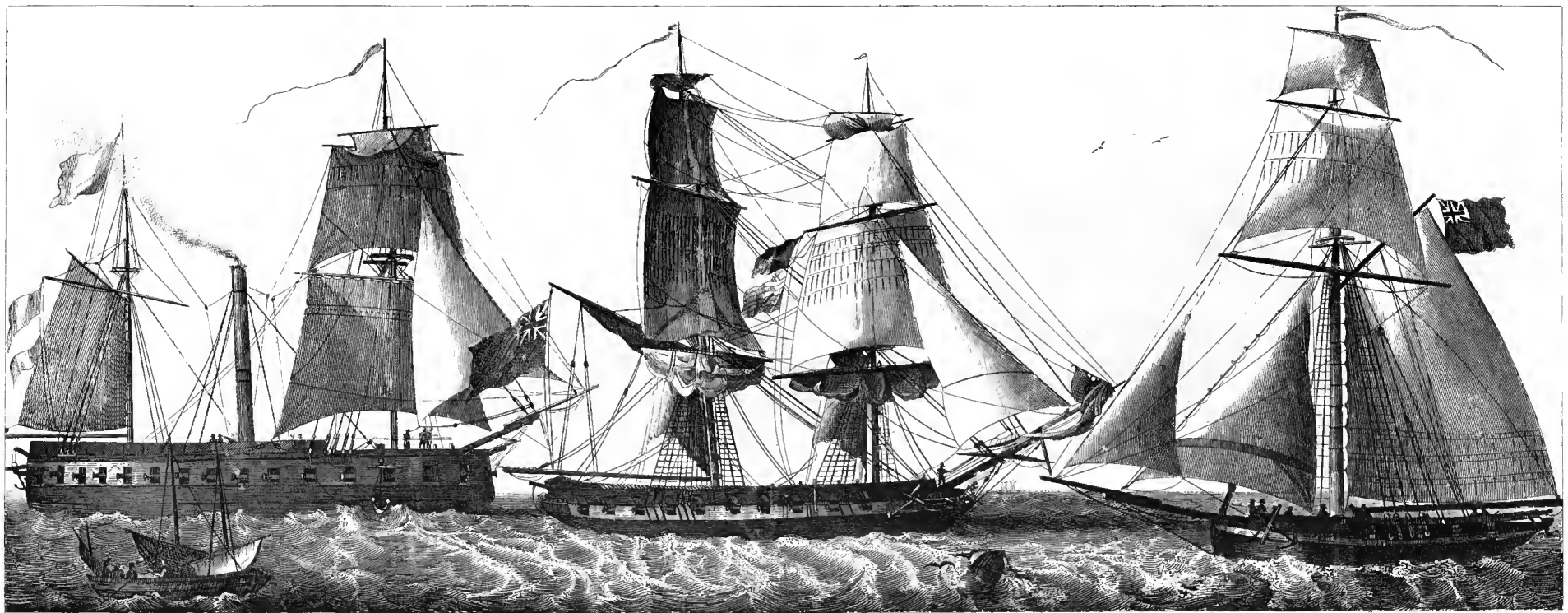


3

4

1

2



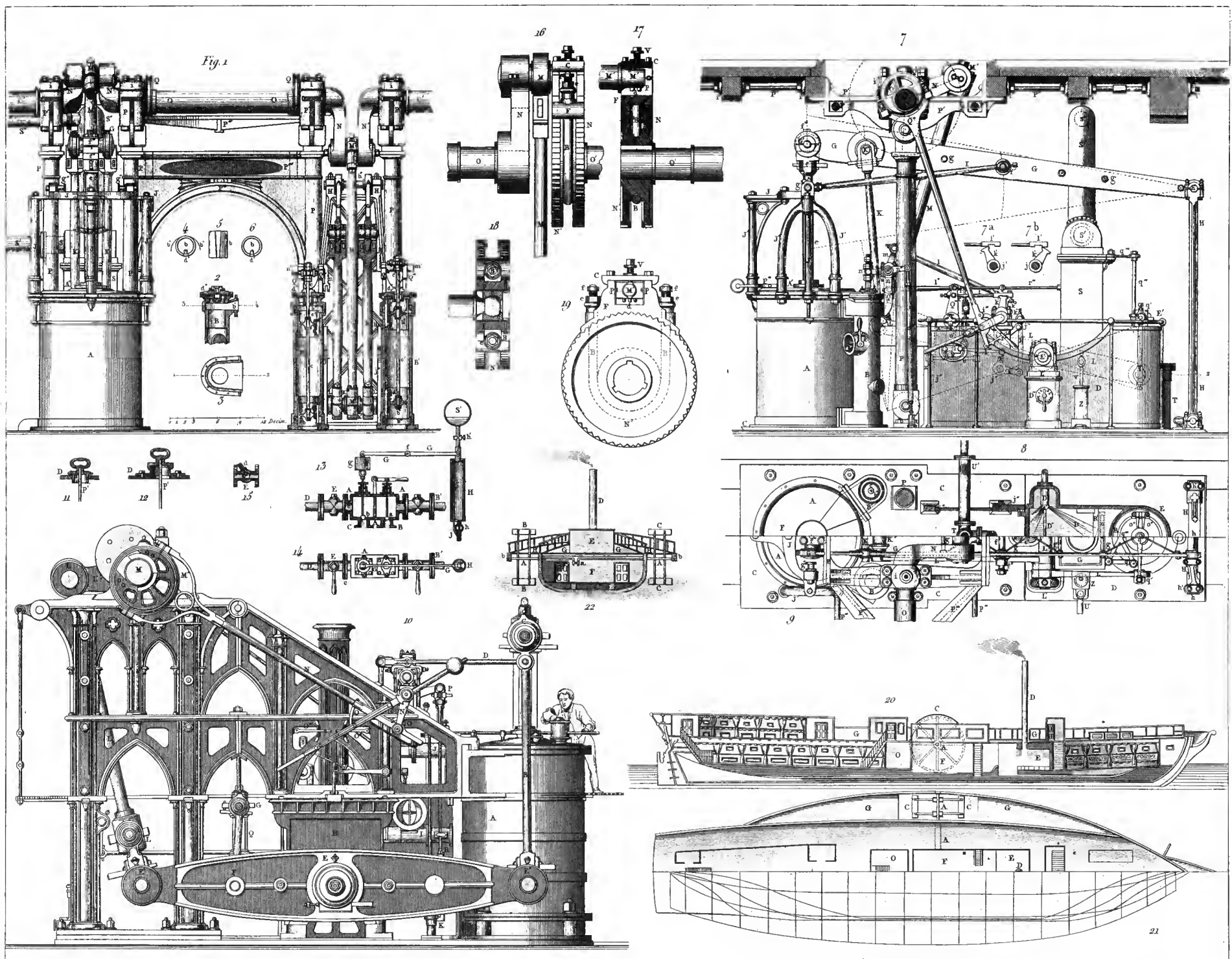


Fig. 1

16

17

7

18

19

8

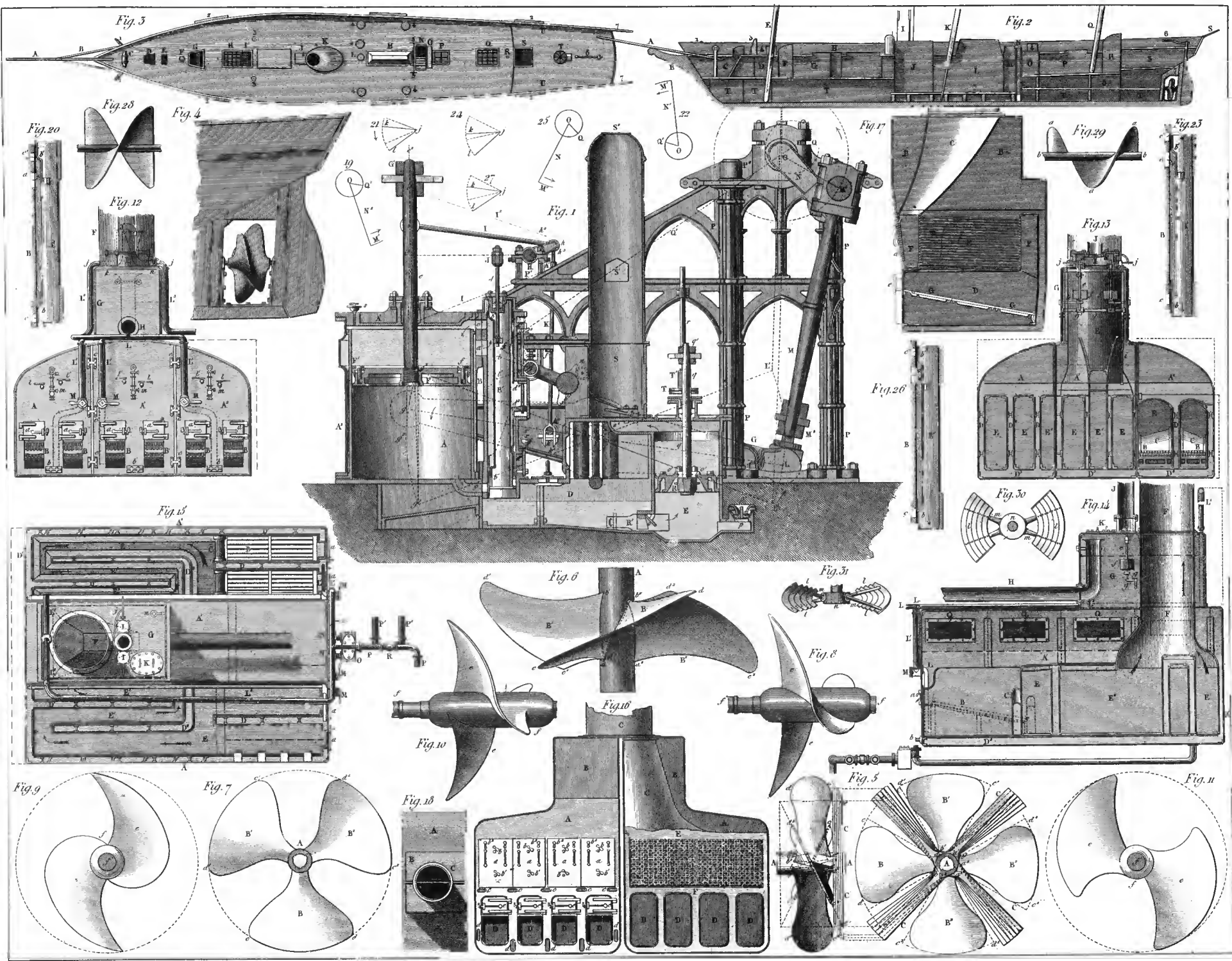
9

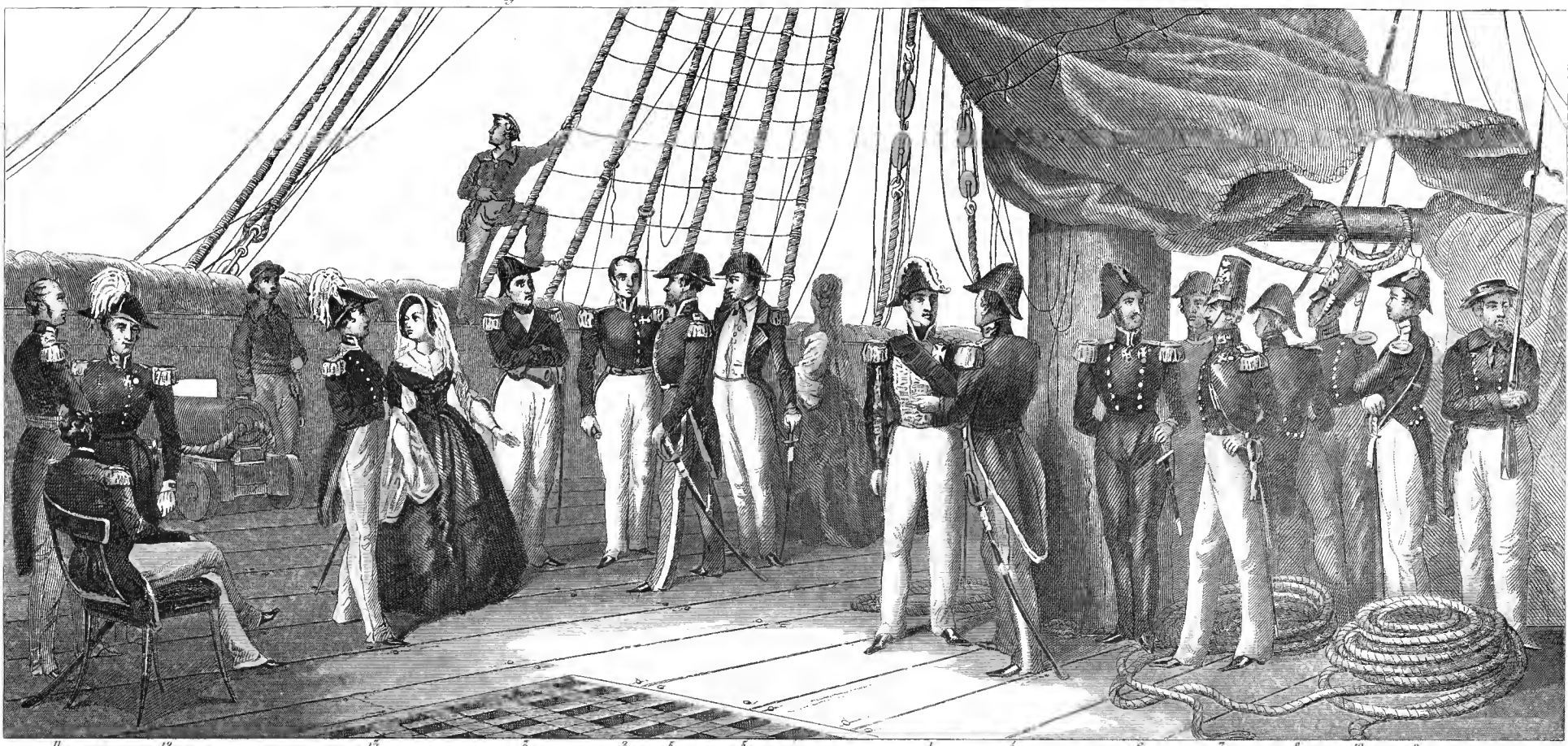
10

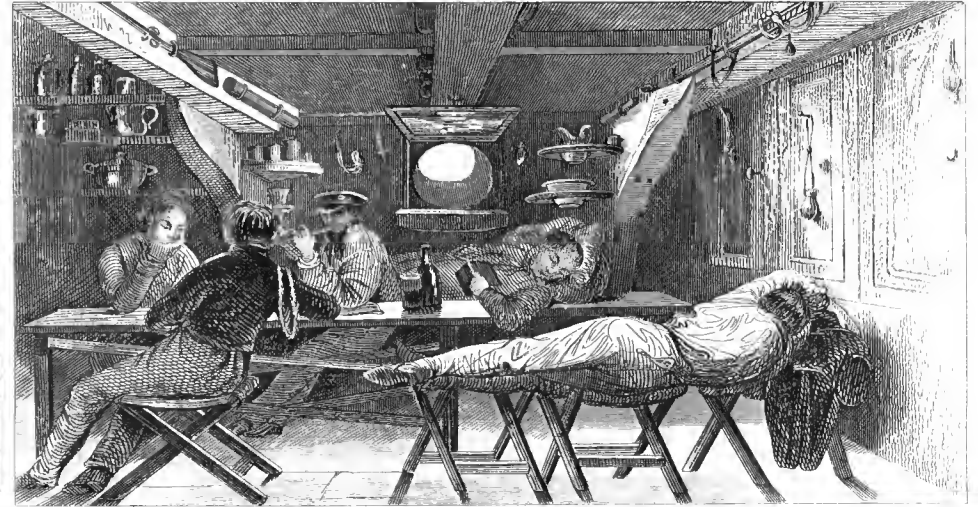
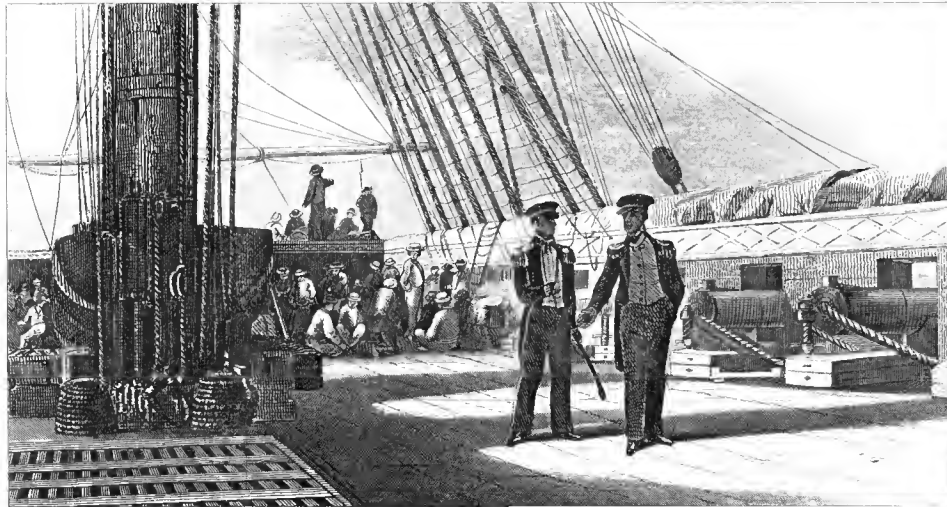
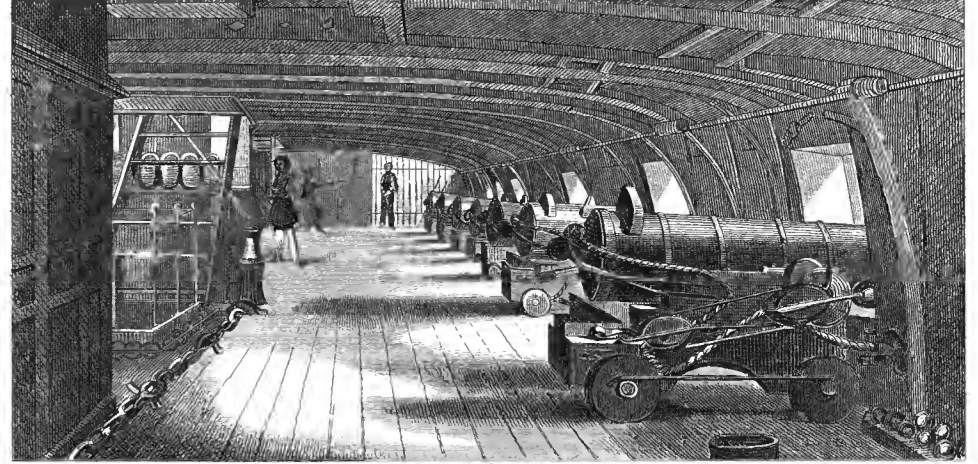
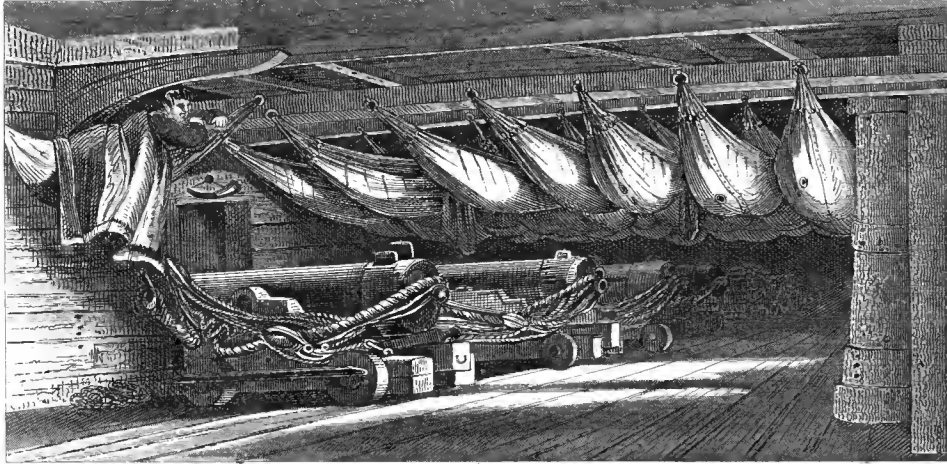
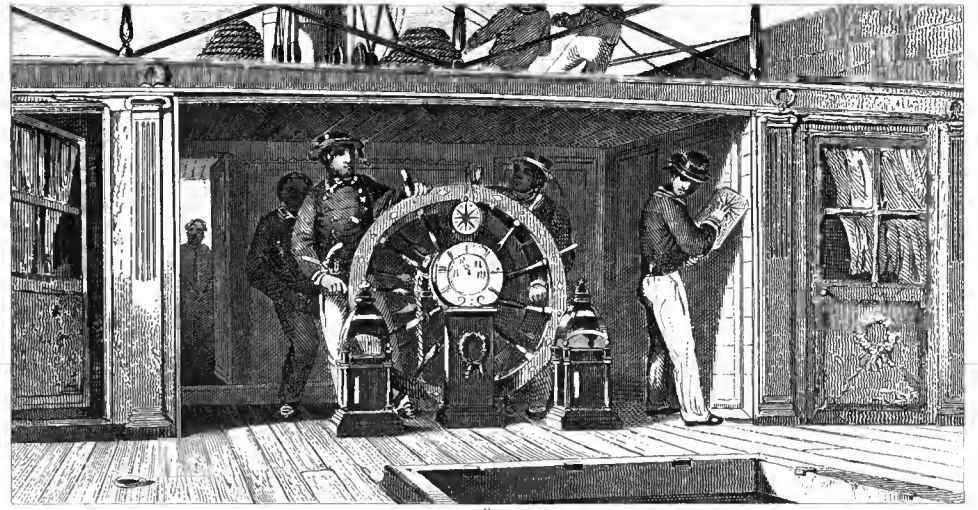
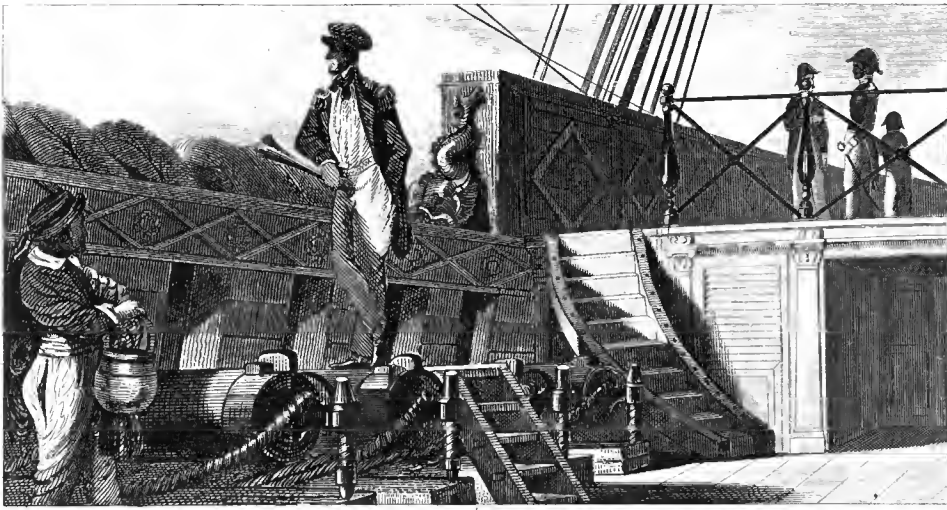
22

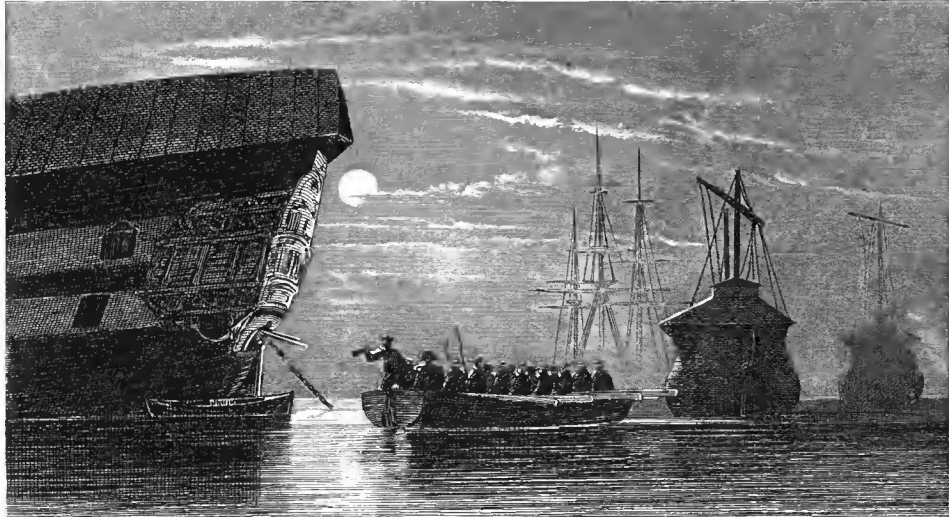
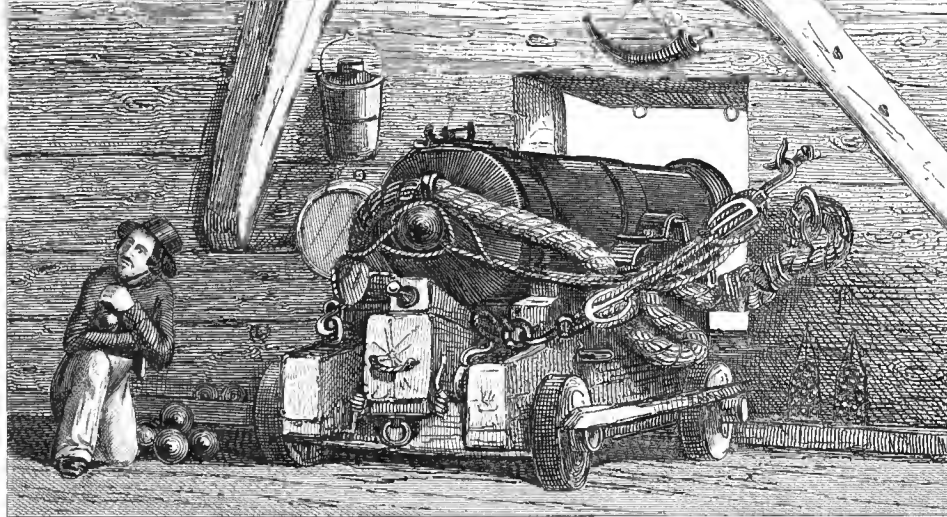
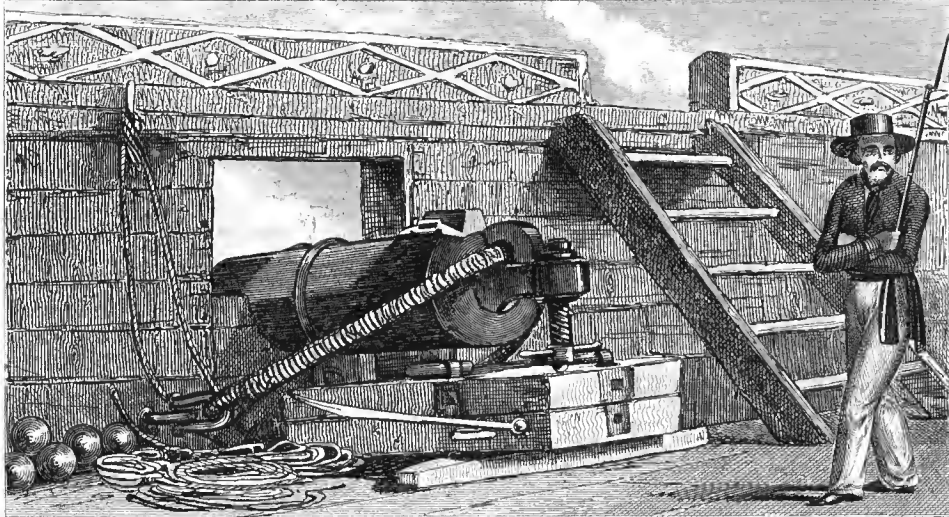
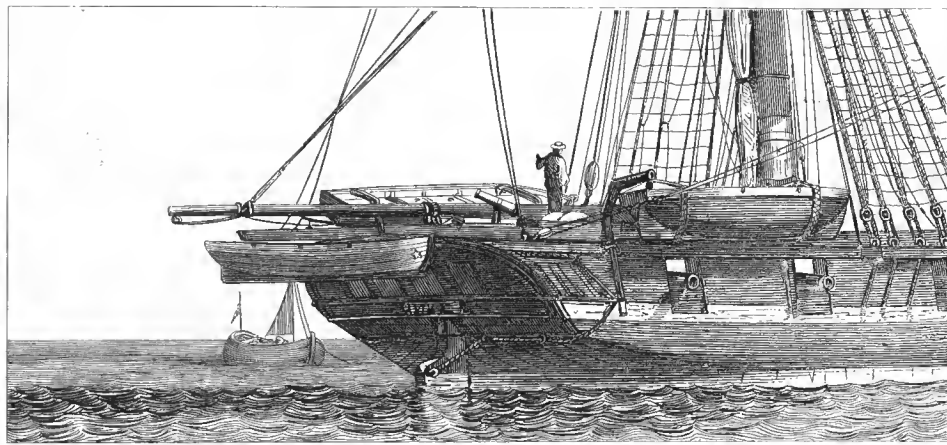
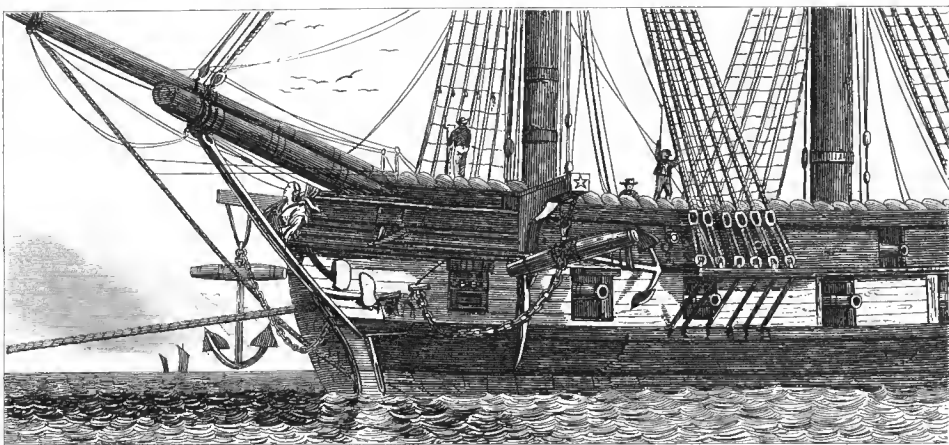
20

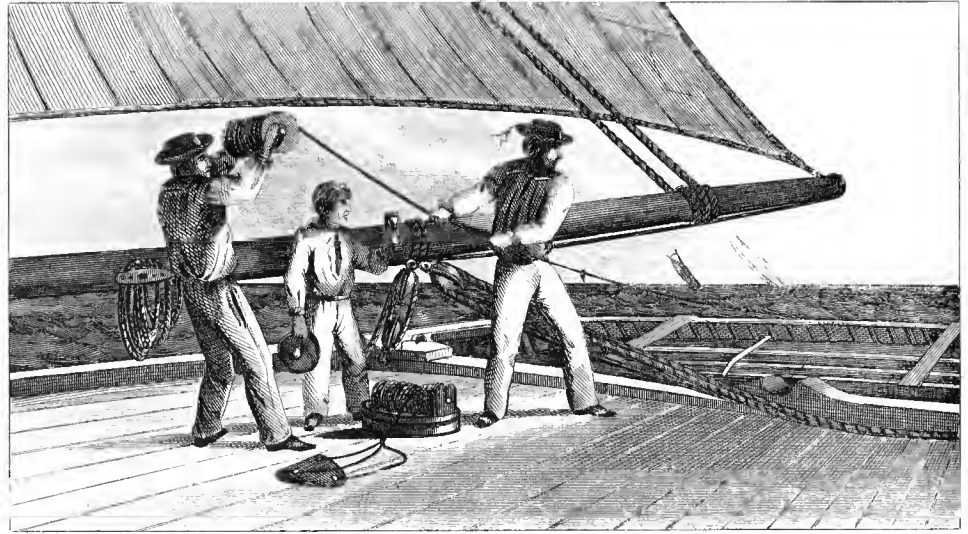
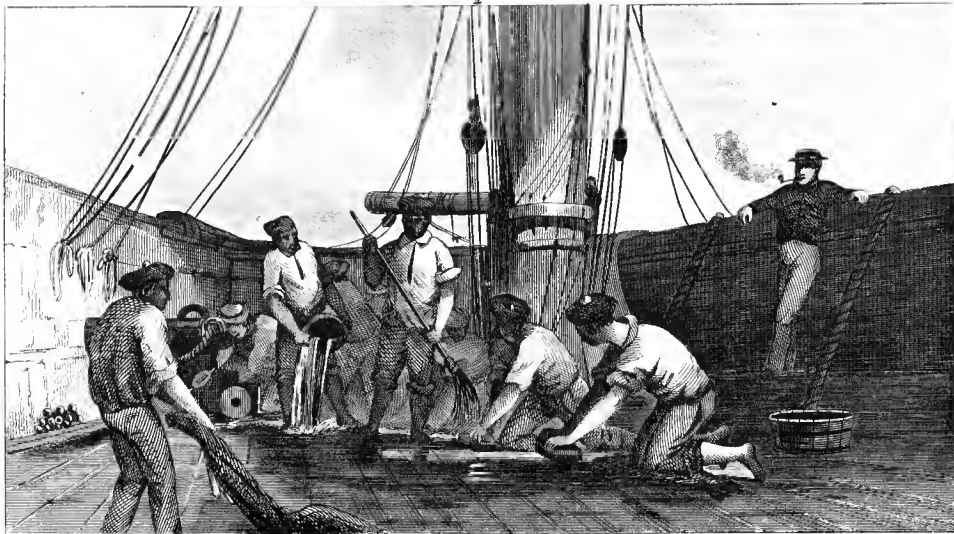
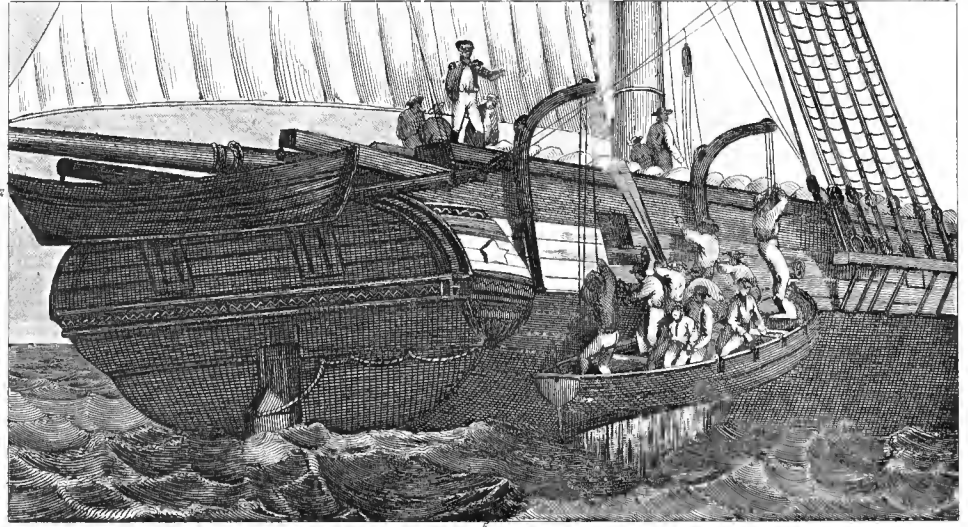
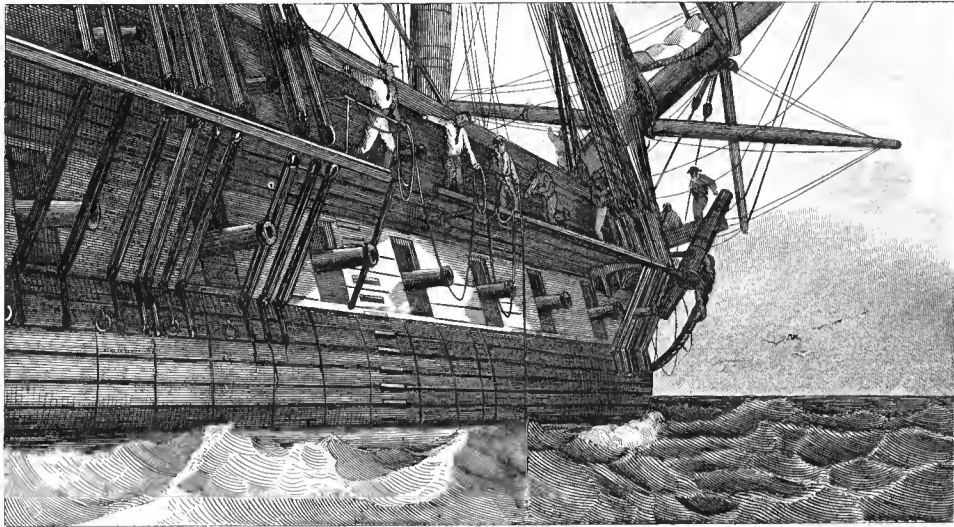
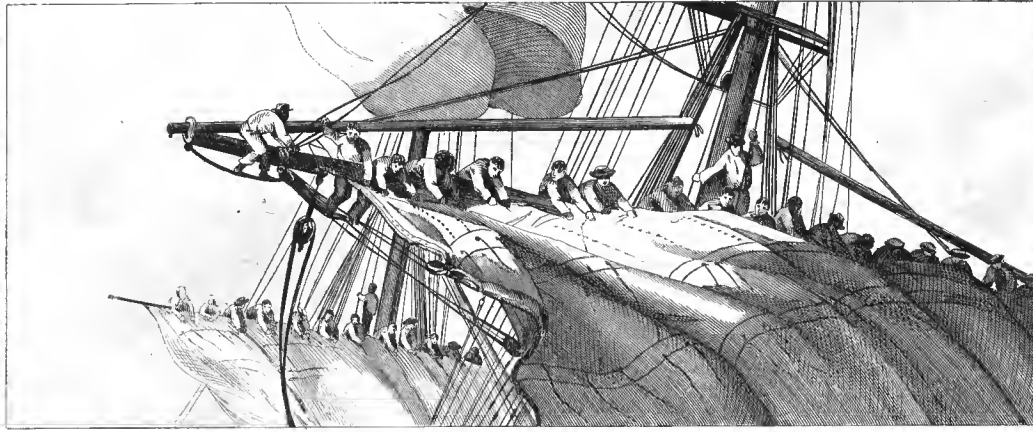
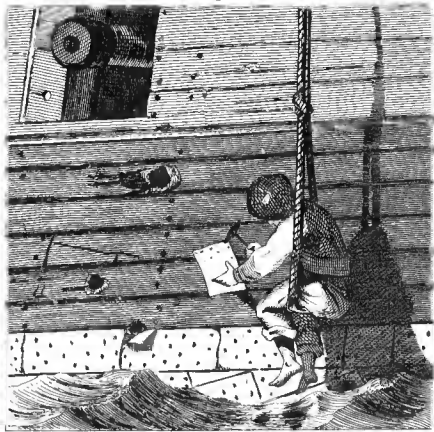
21

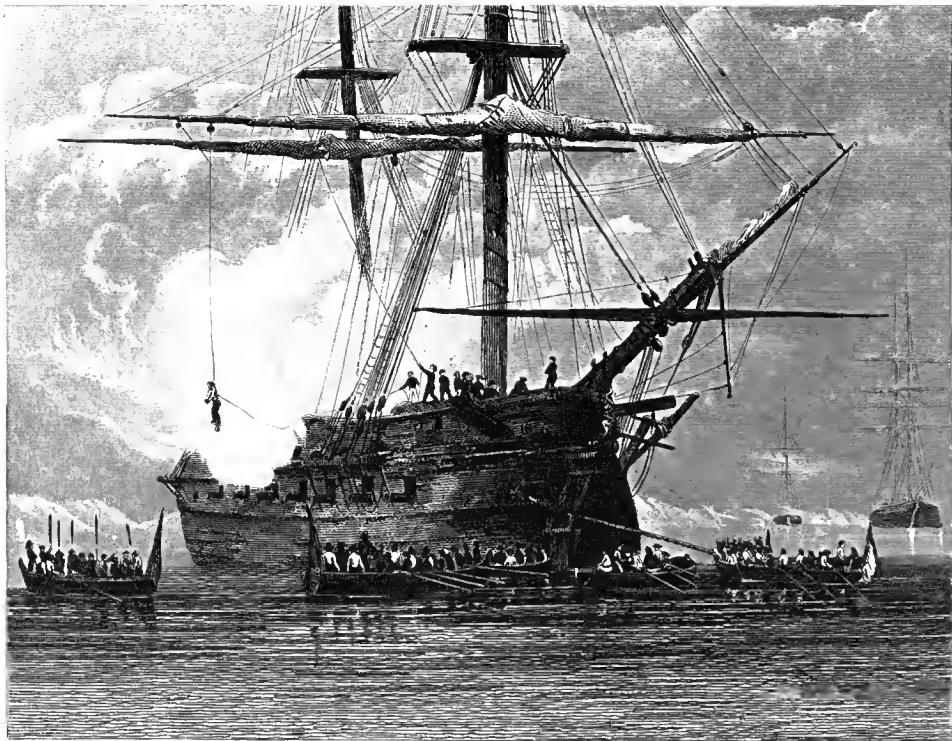




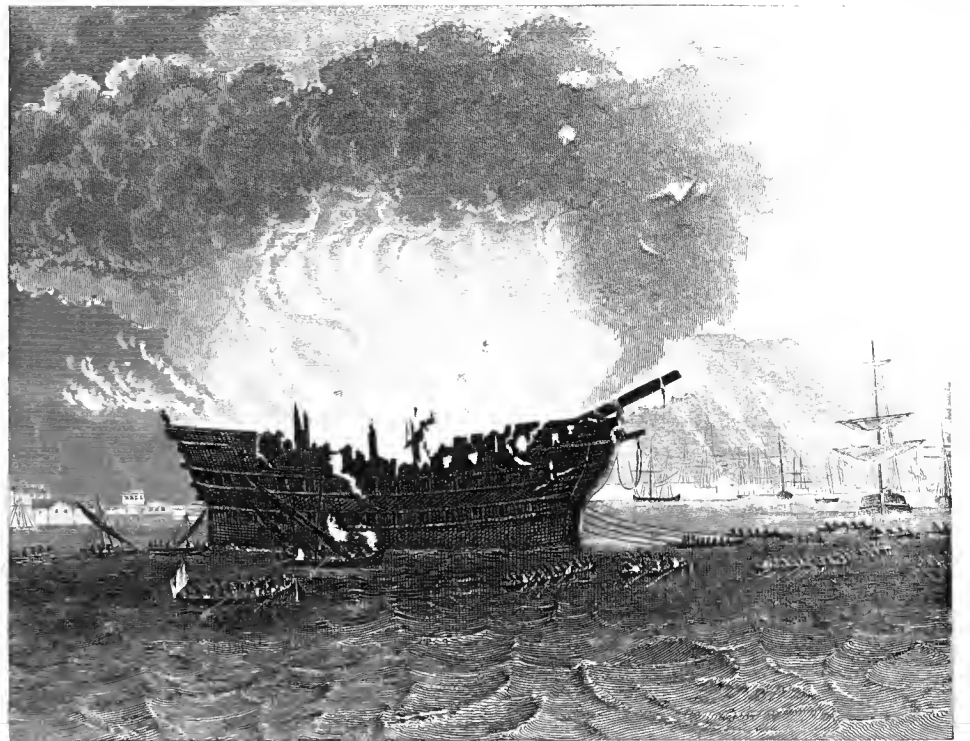




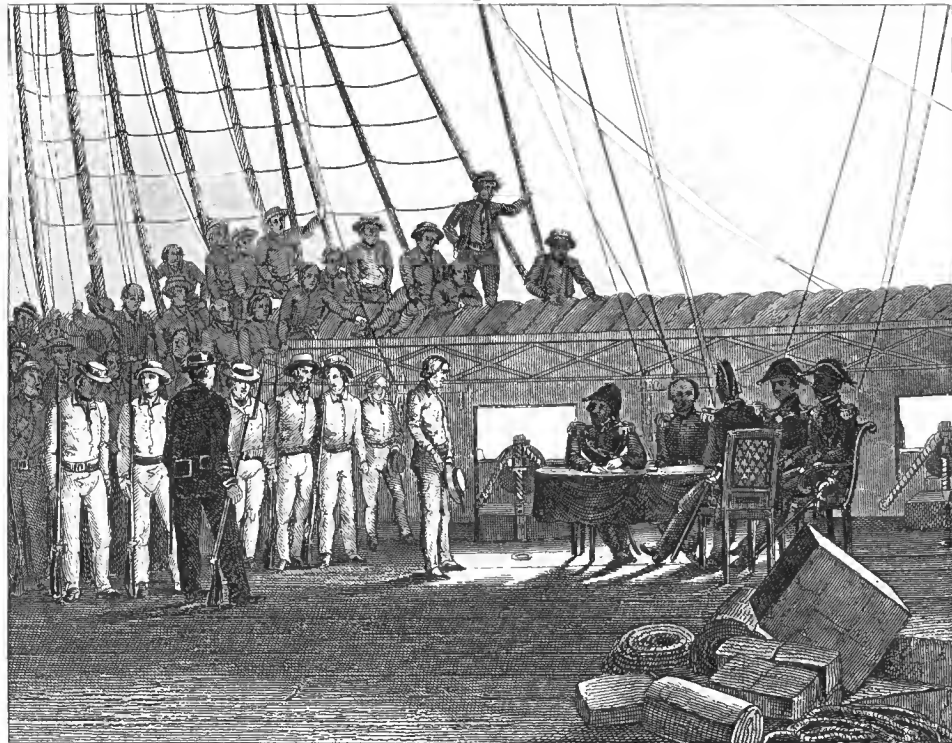




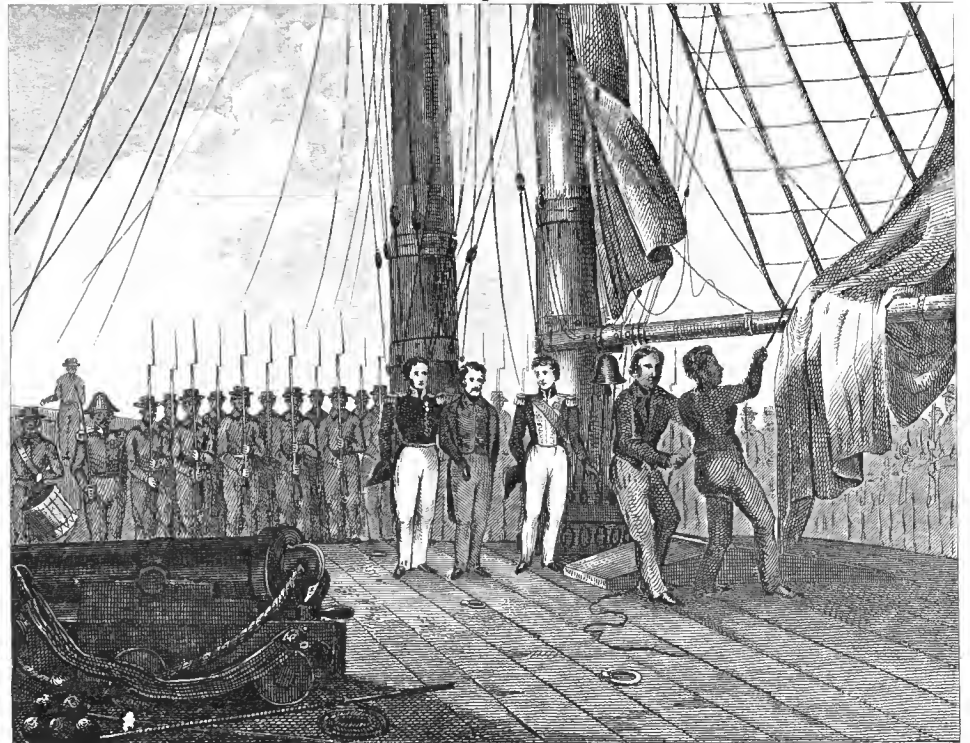
2



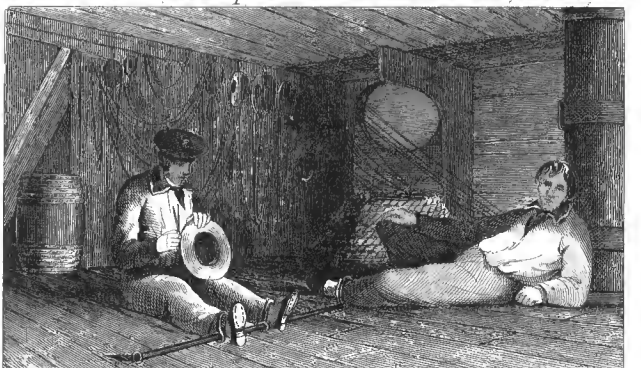
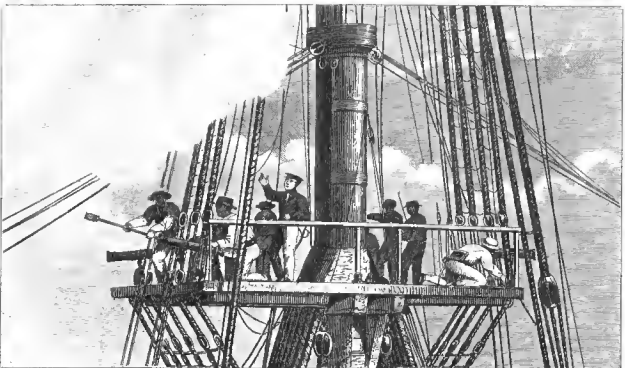
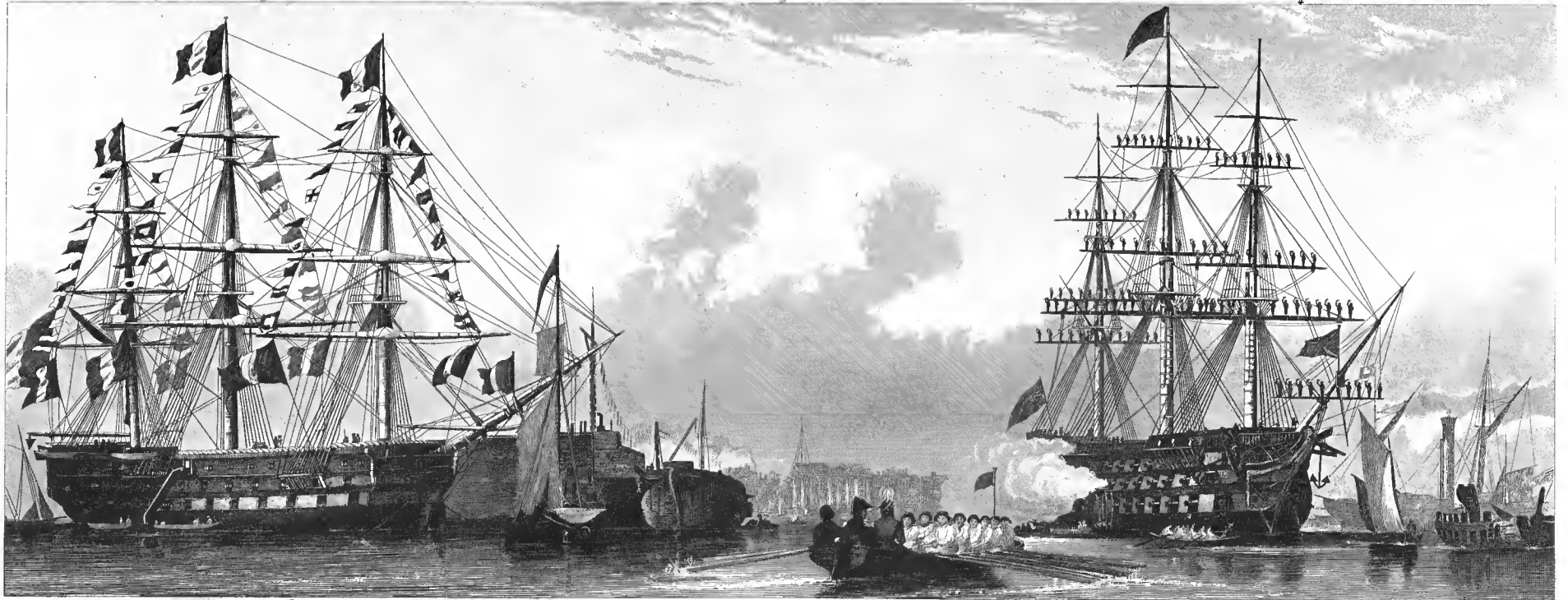
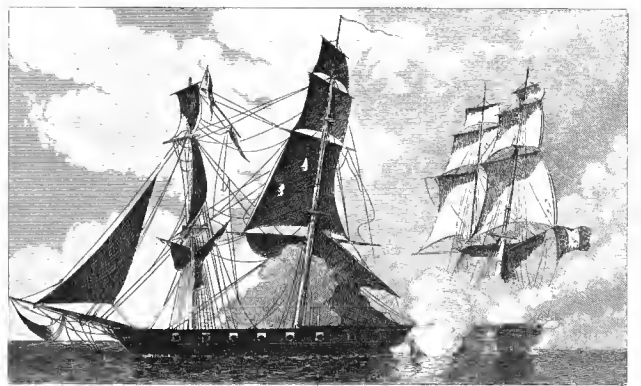
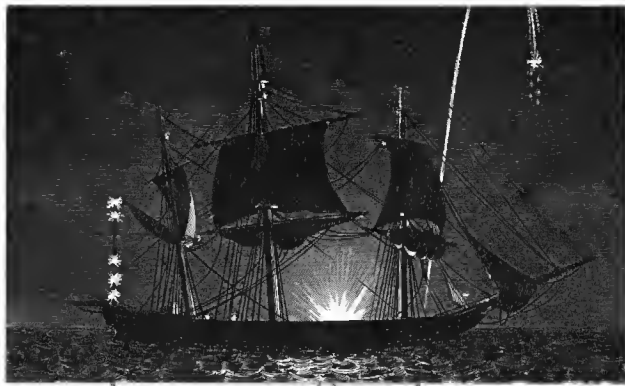
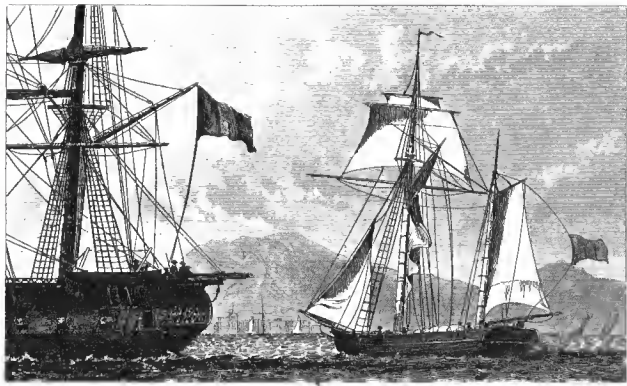
4

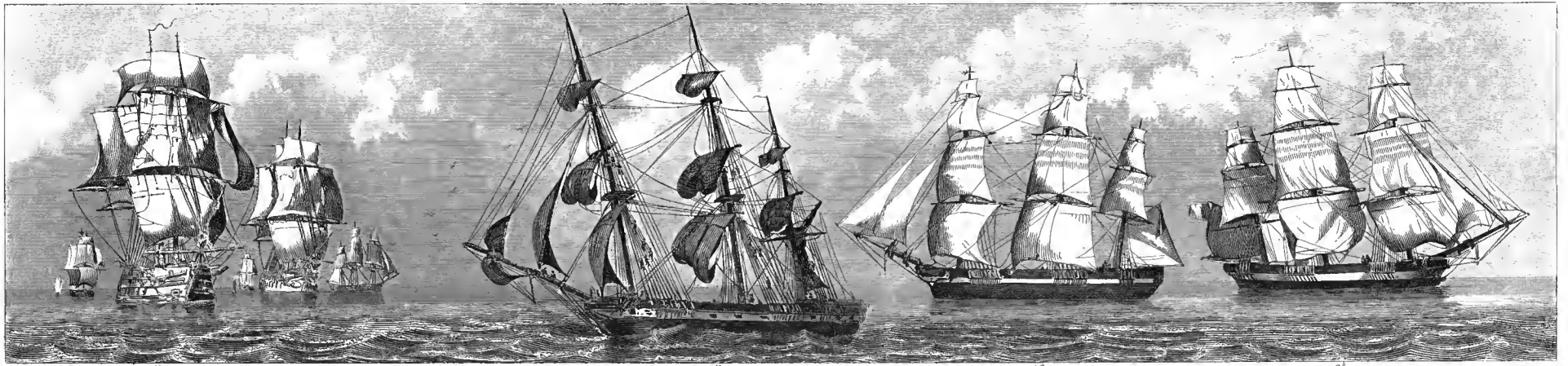


1



3



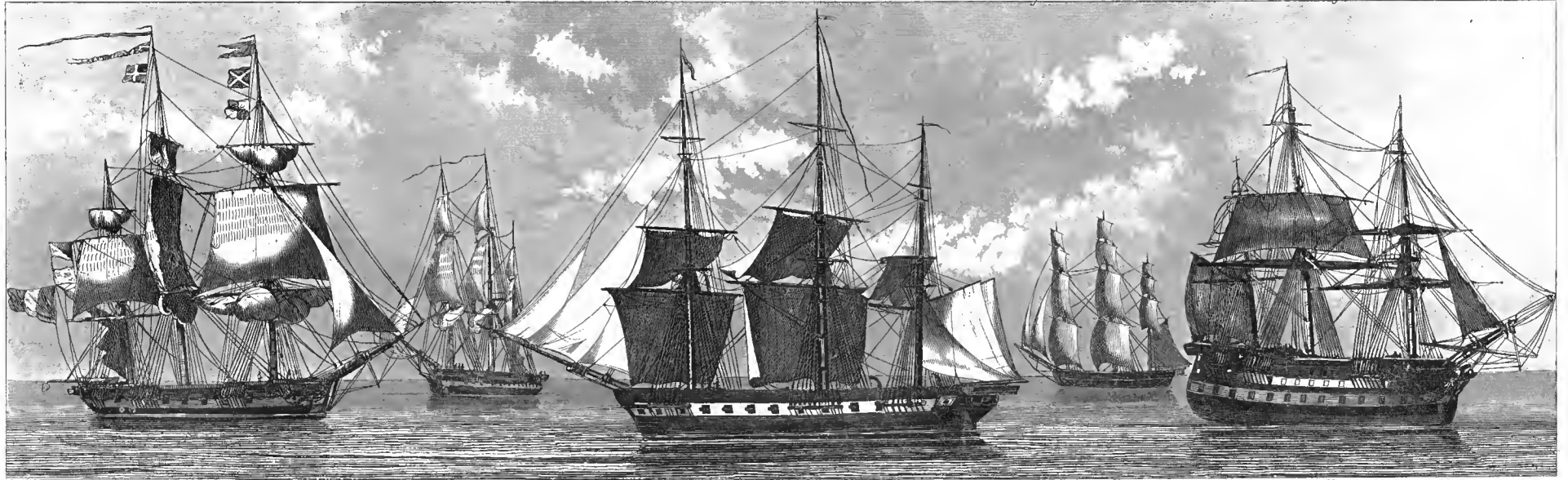


10

11

9^a

9^b



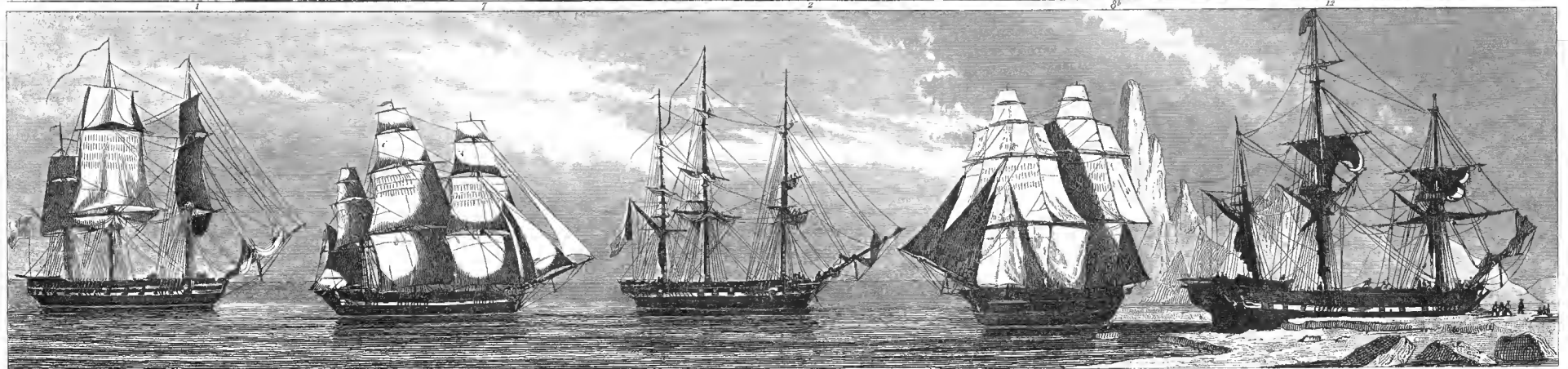
1

7

2

8^a

12



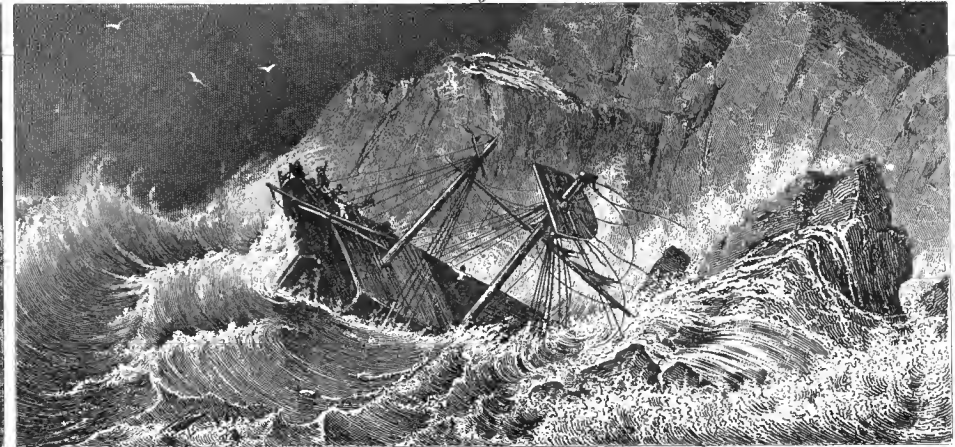
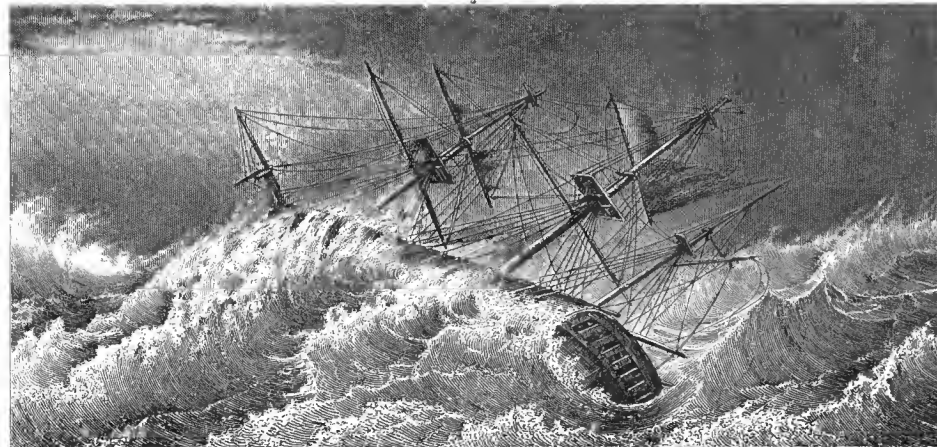
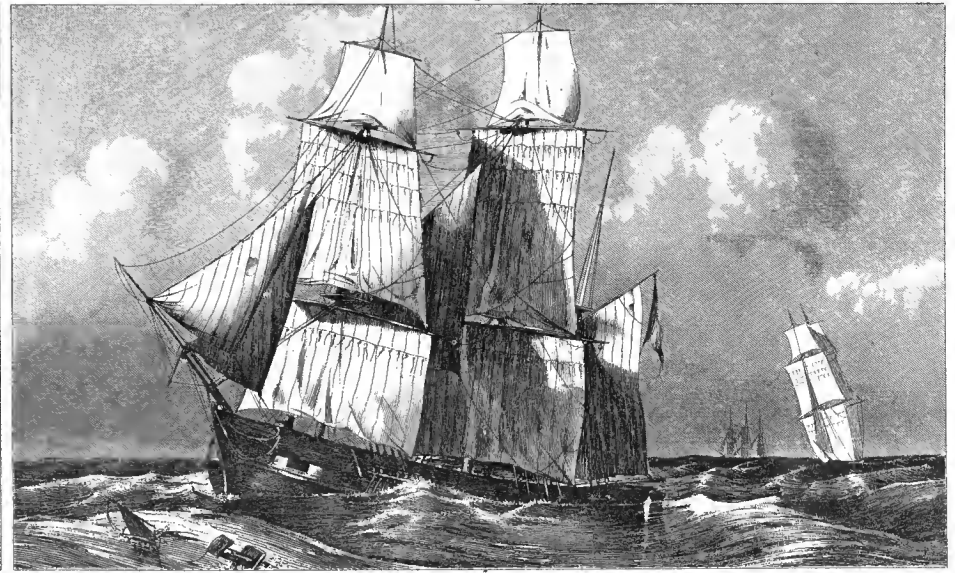
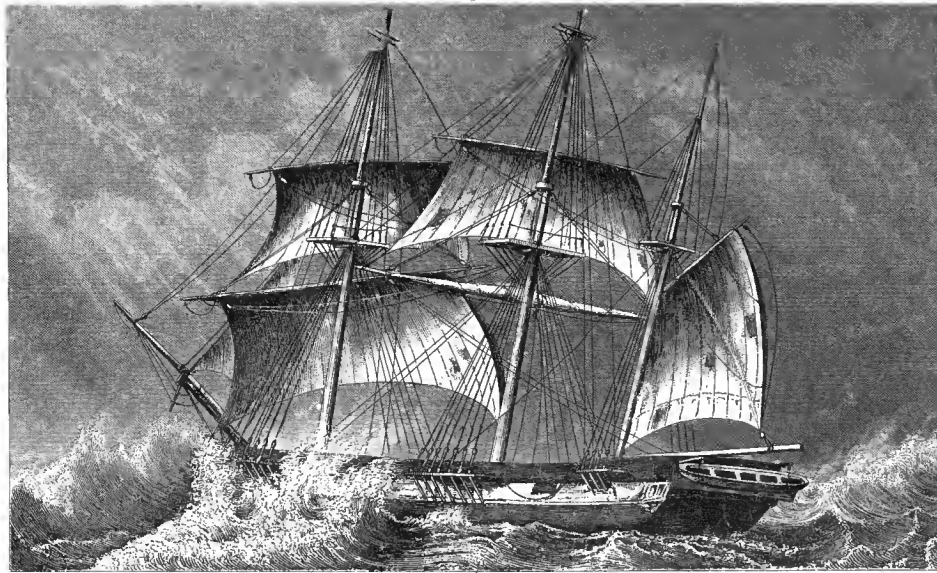
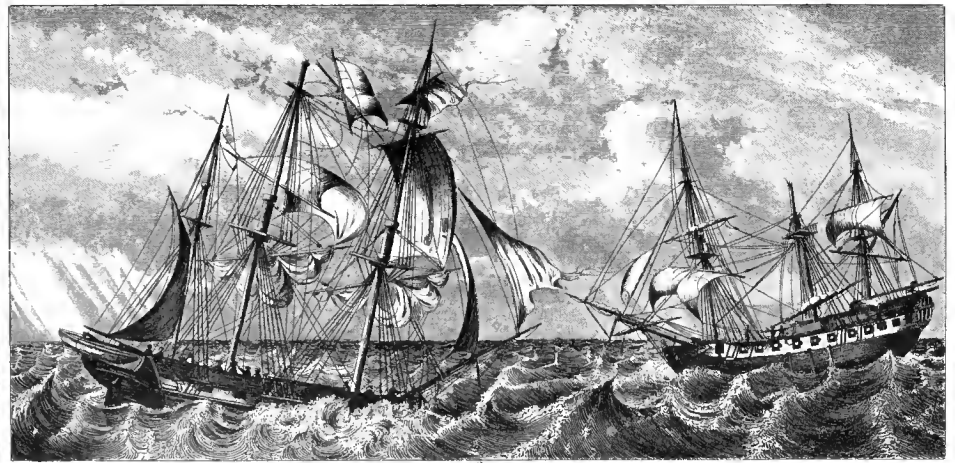
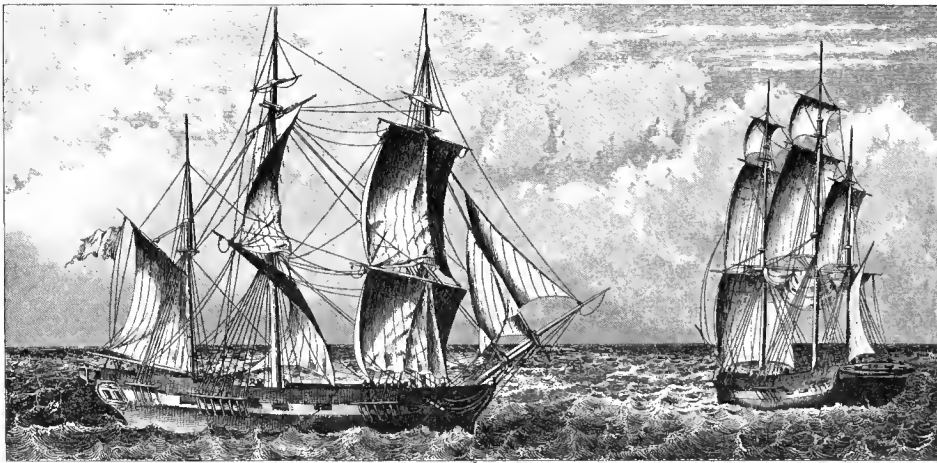
6

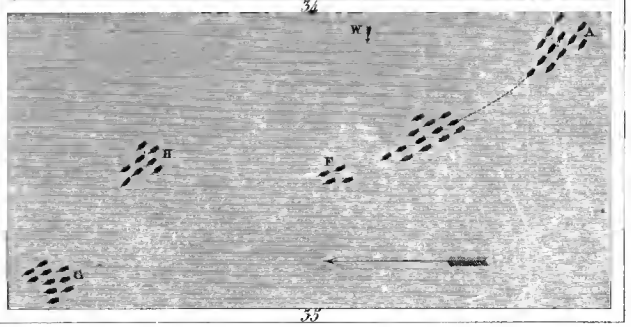
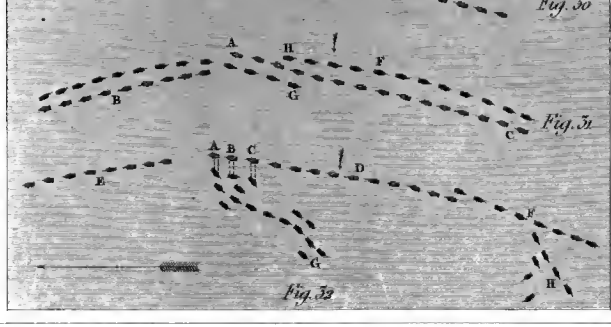
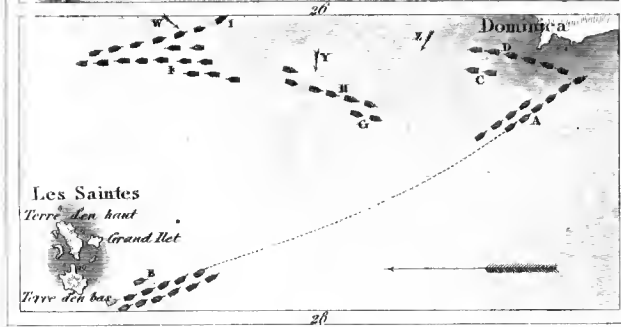
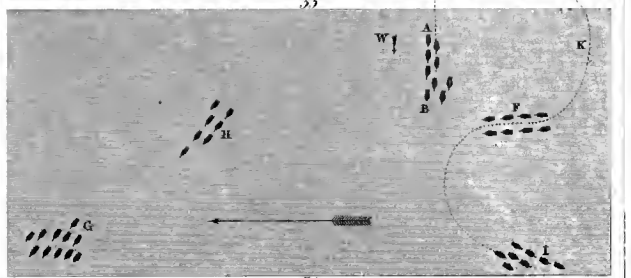
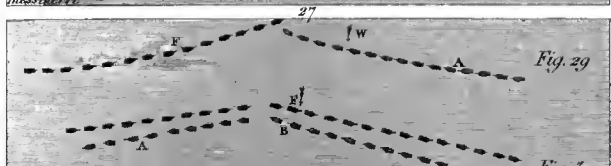
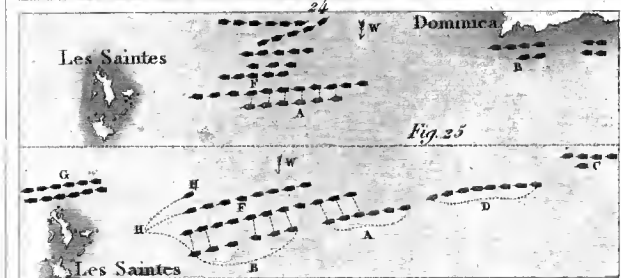
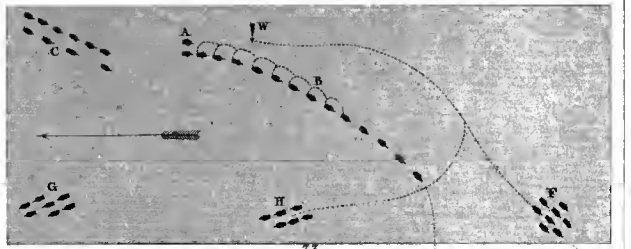
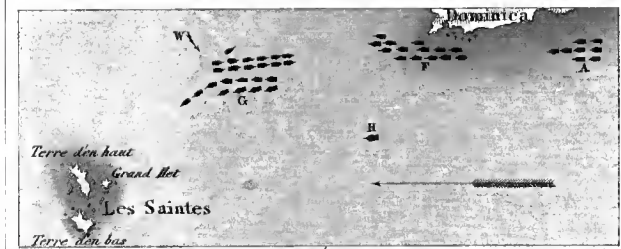
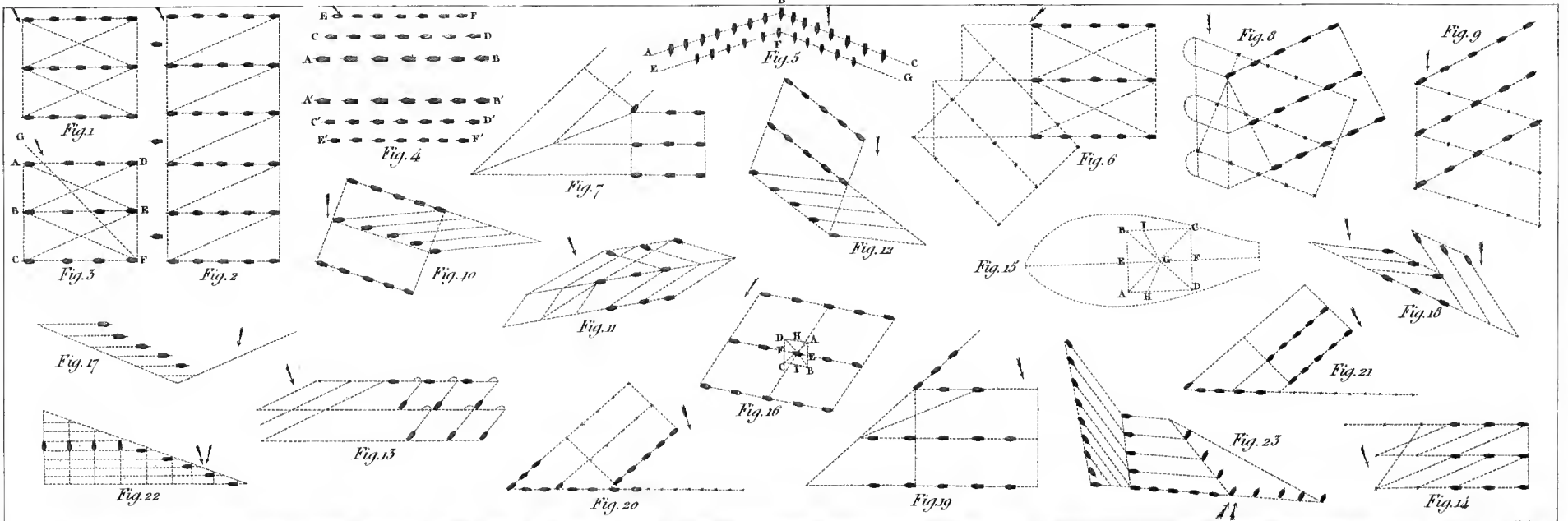
8^a

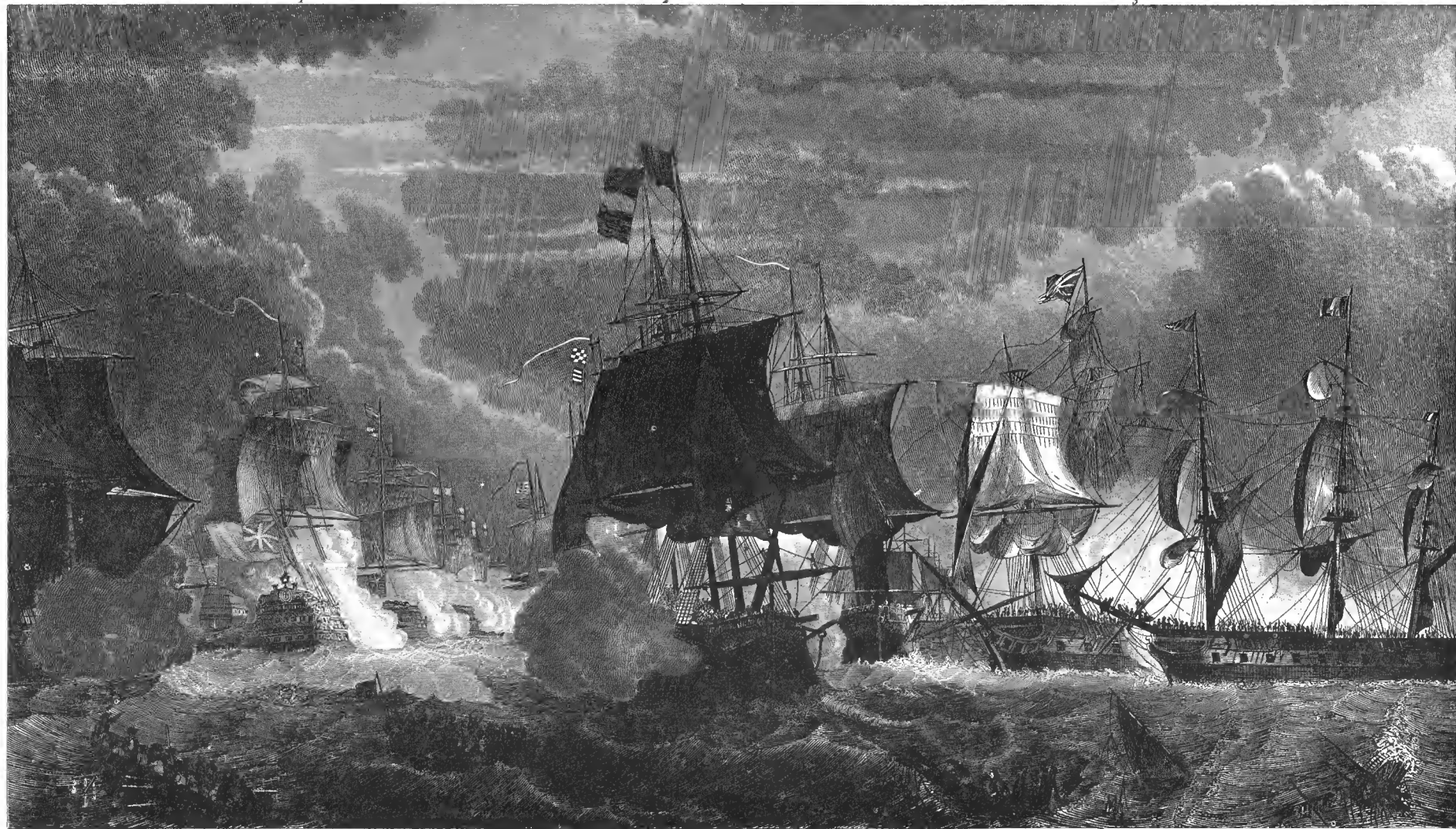
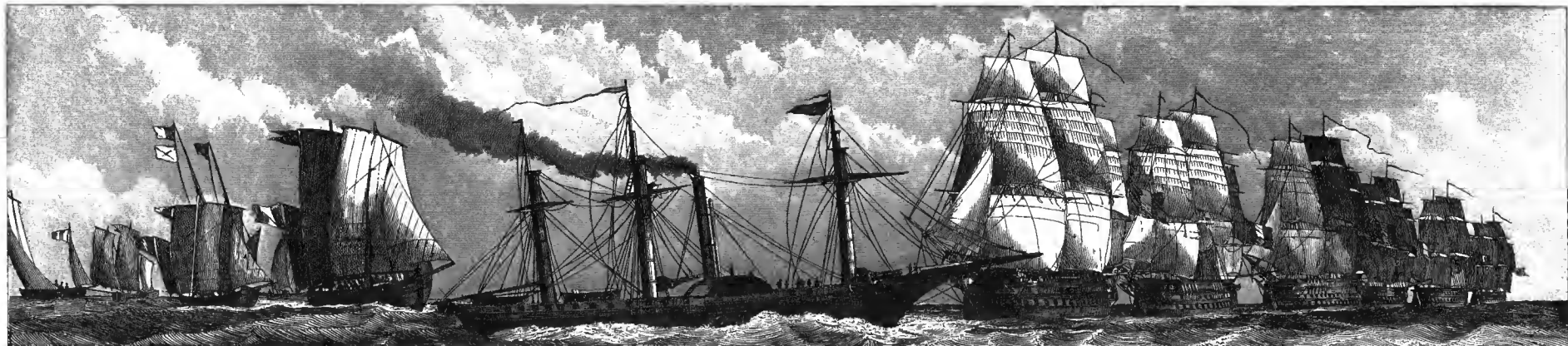
5

4

3



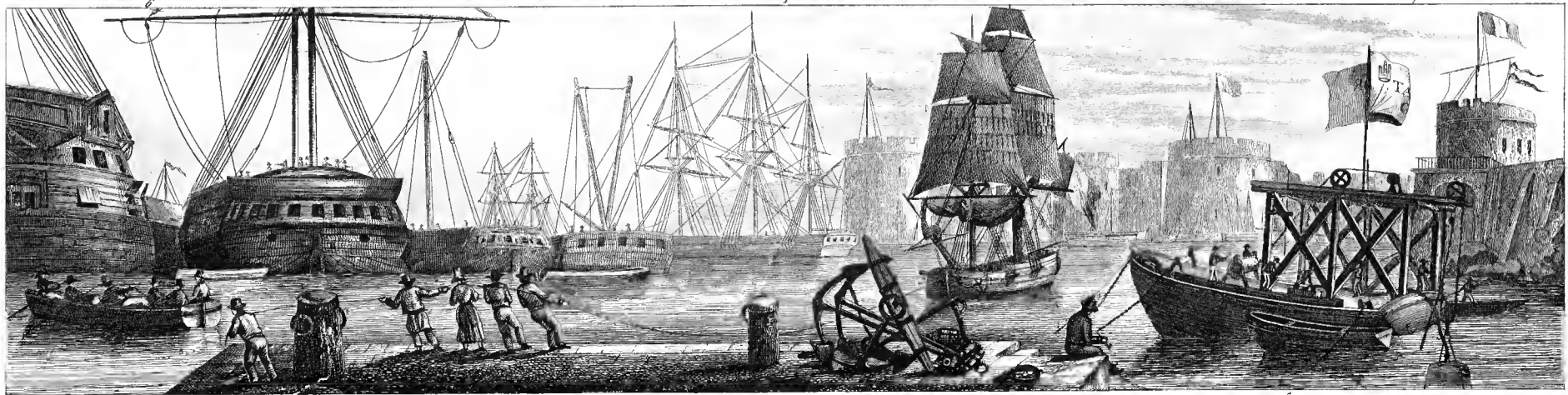
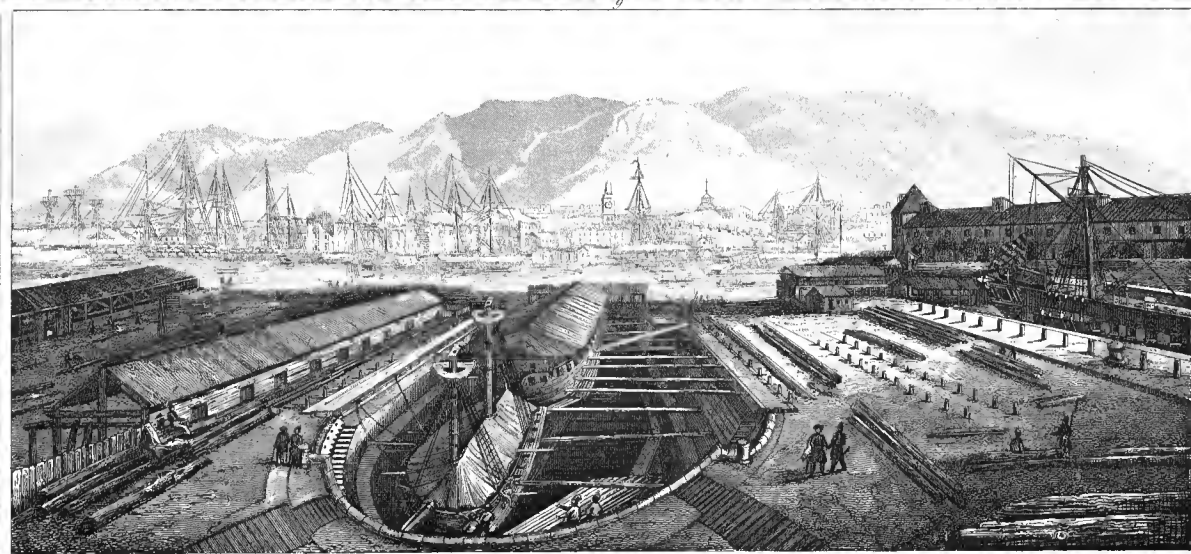
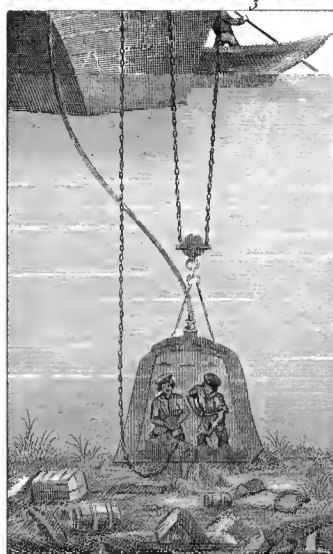
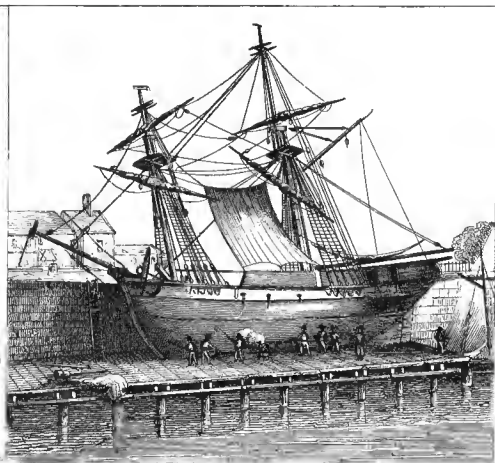
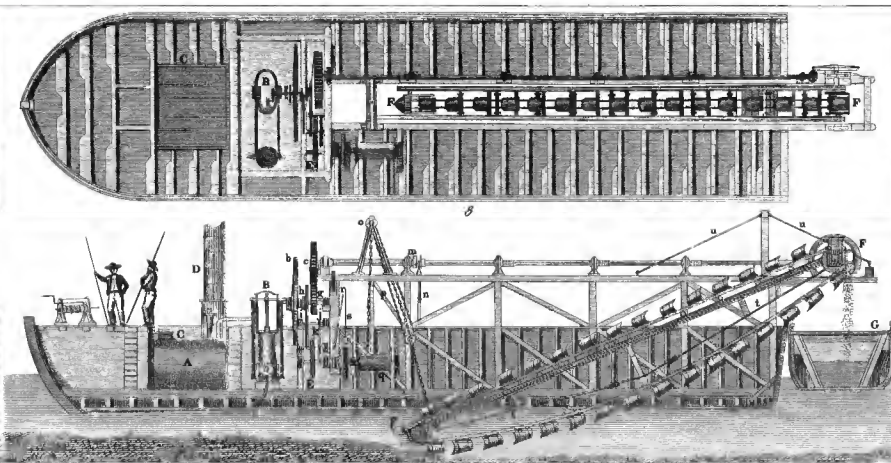
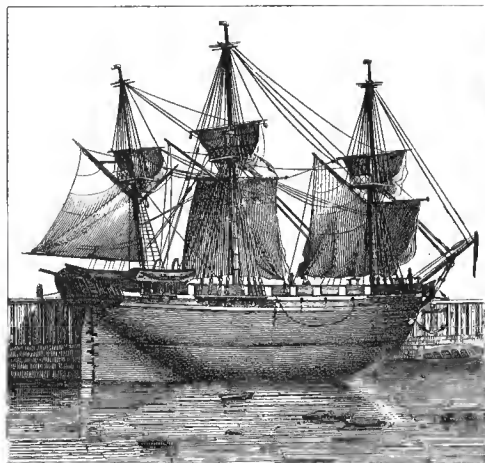


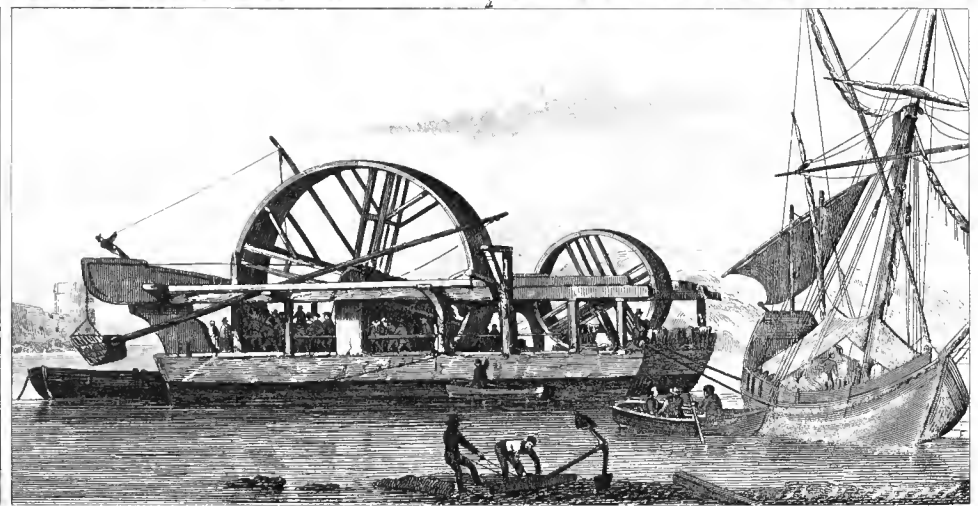
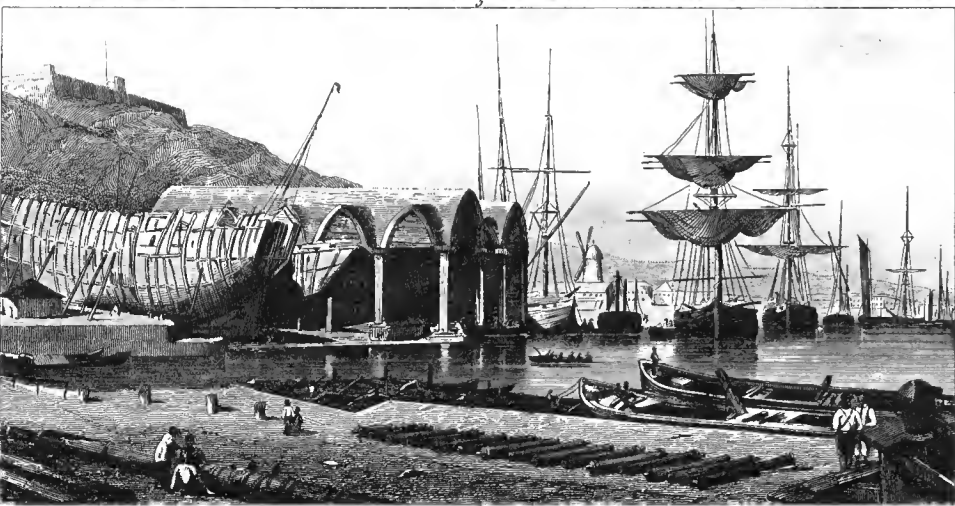
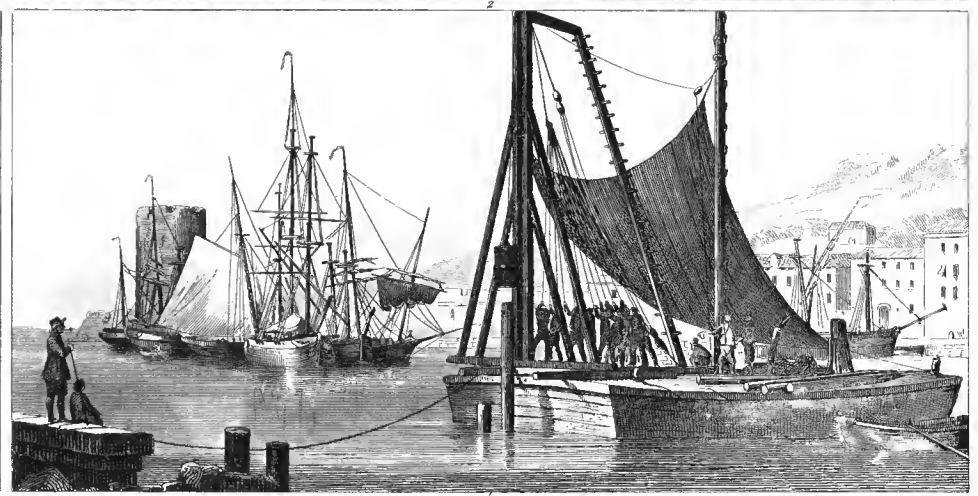
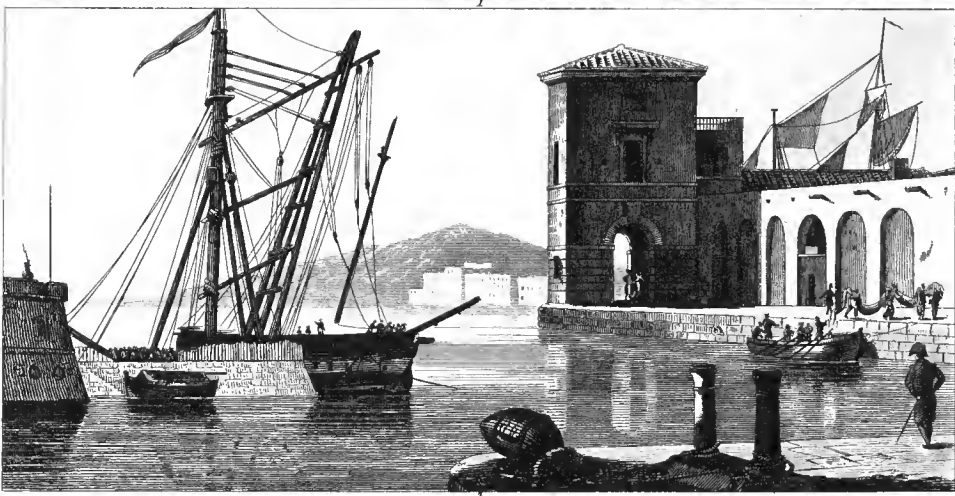
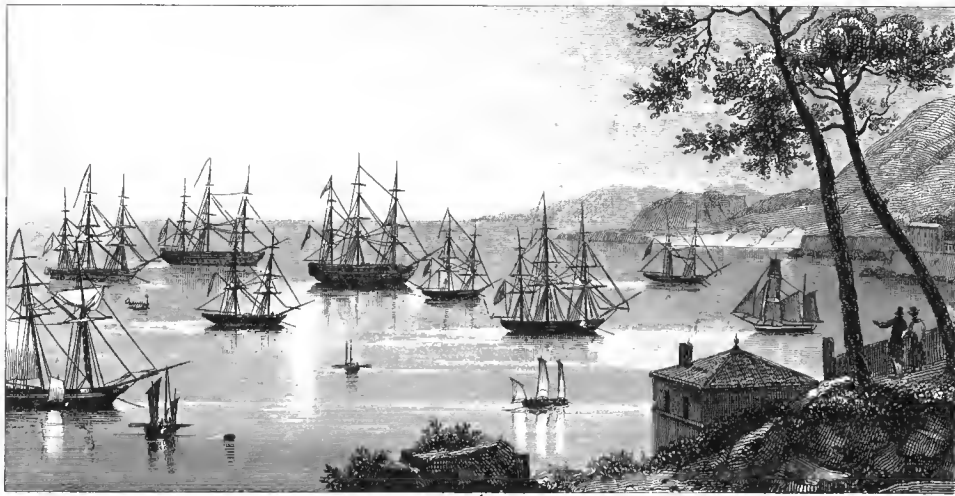



a

b

c







ICONOGRAPHIC
E N C Y C L O P Æ D I A .

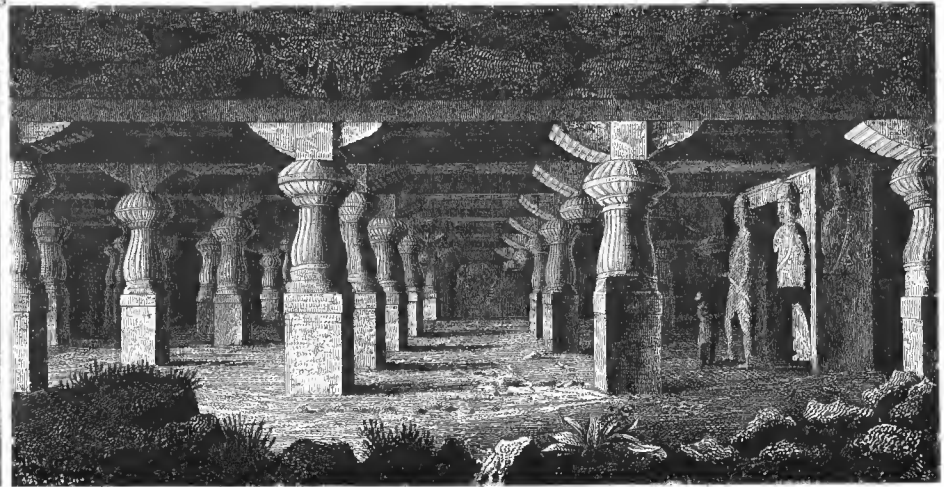
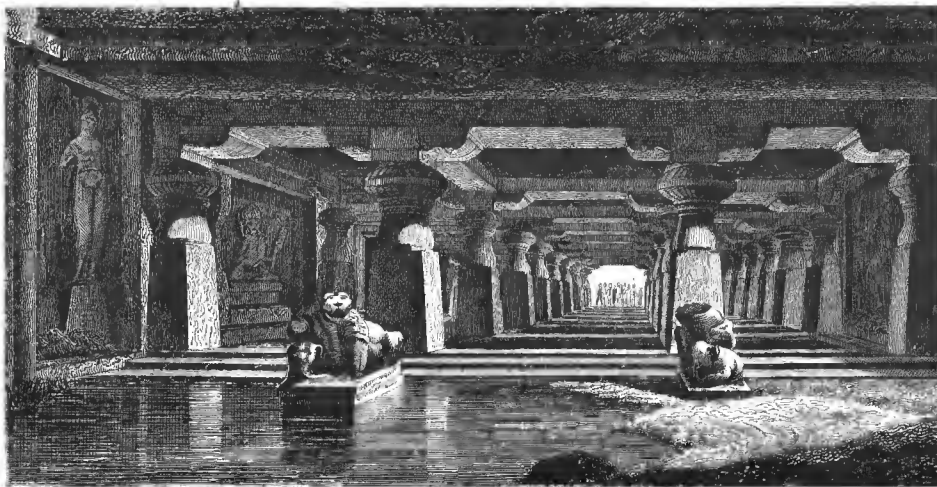
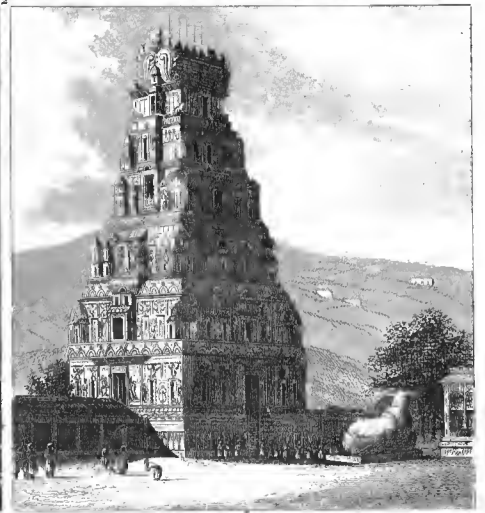
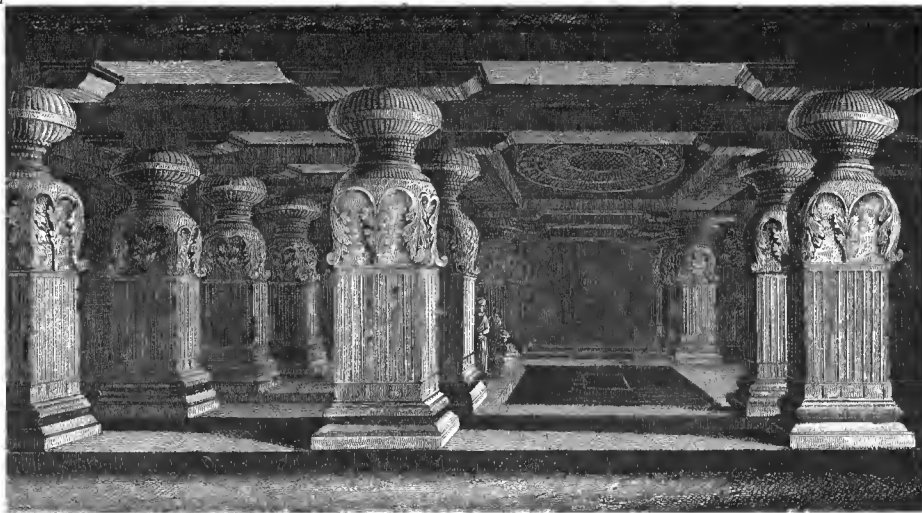
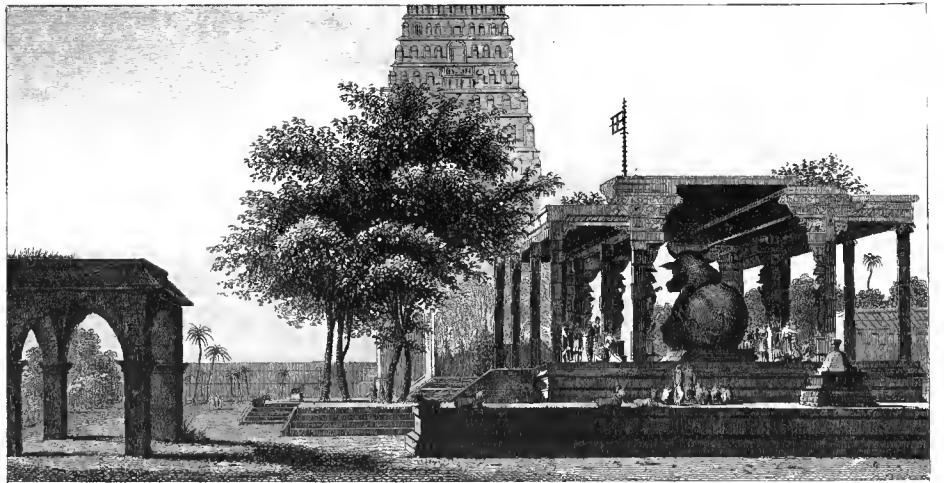
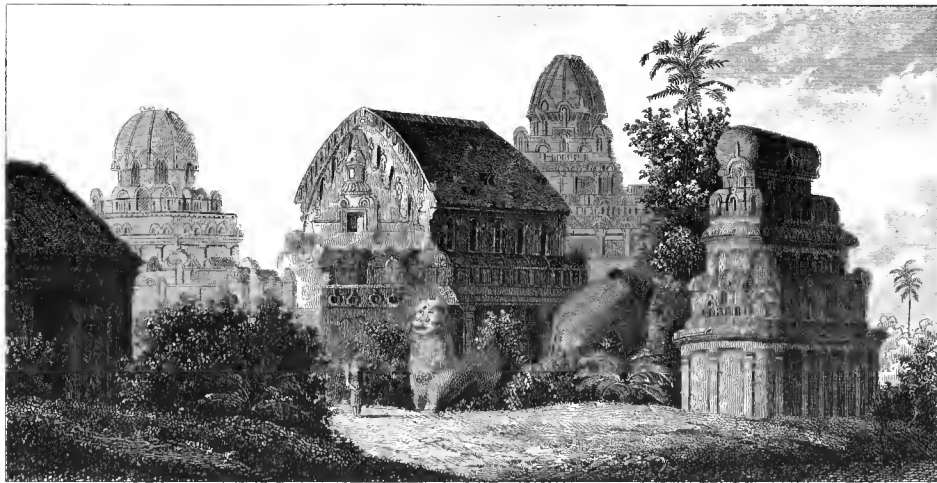
DIVISION VII.

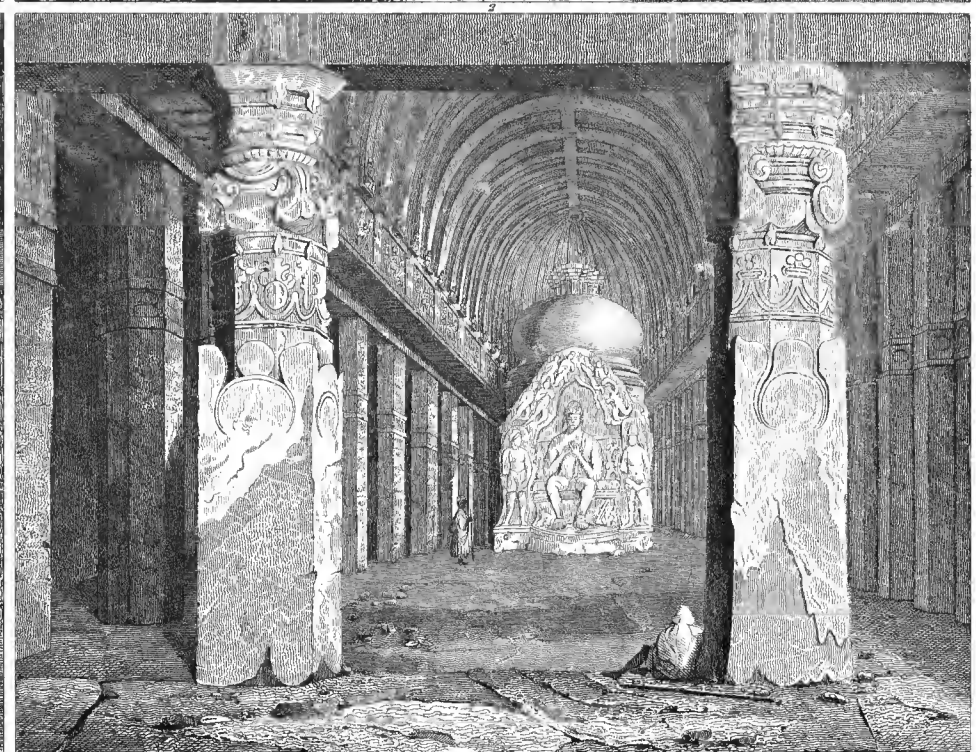
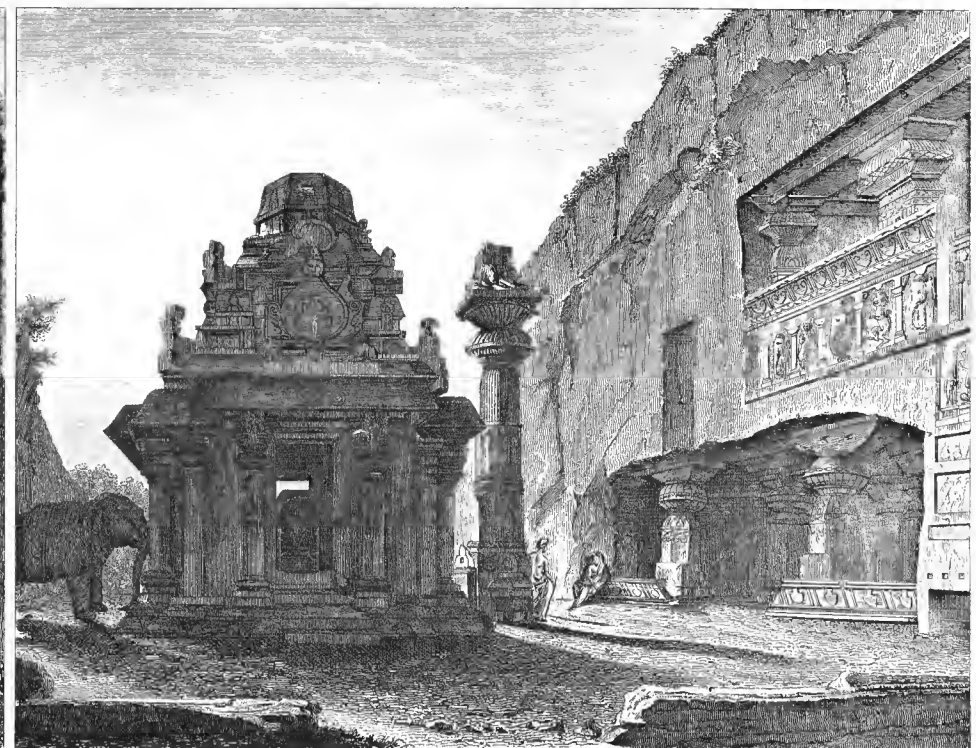
ARCHITECTURE.

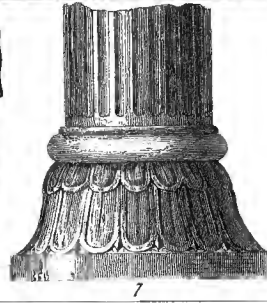
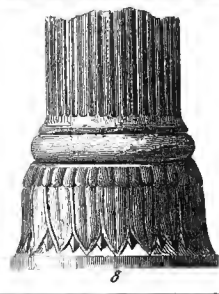
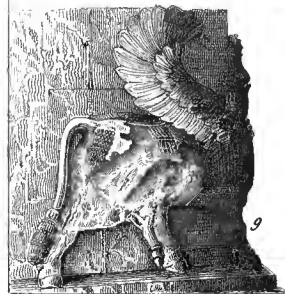
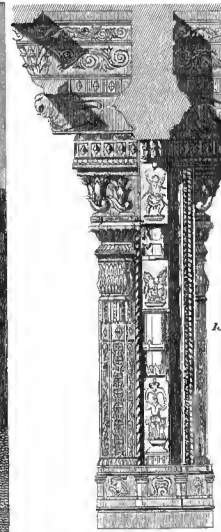
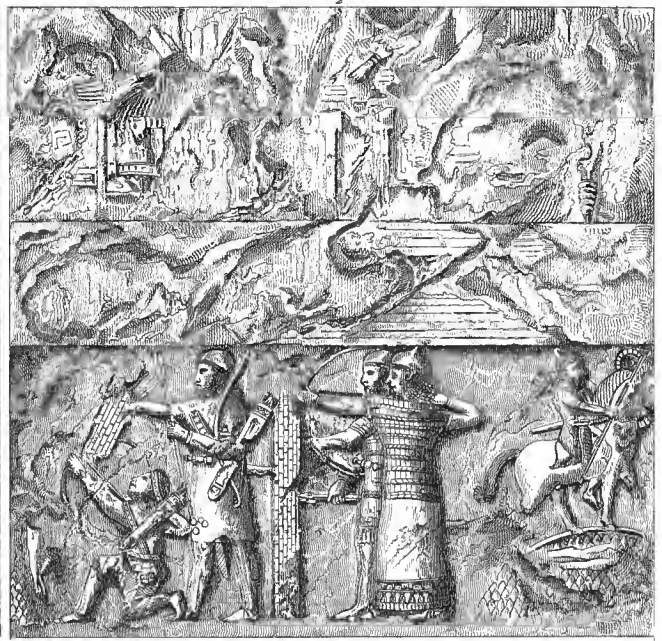
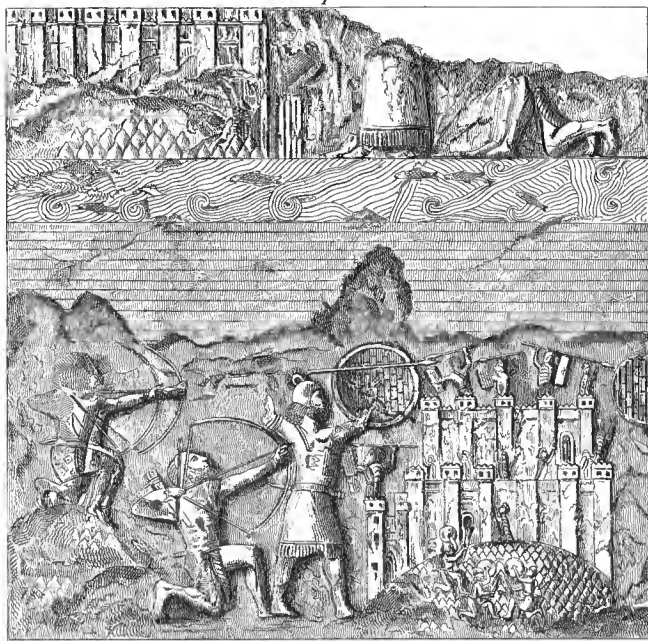
SIXTY PLATES.

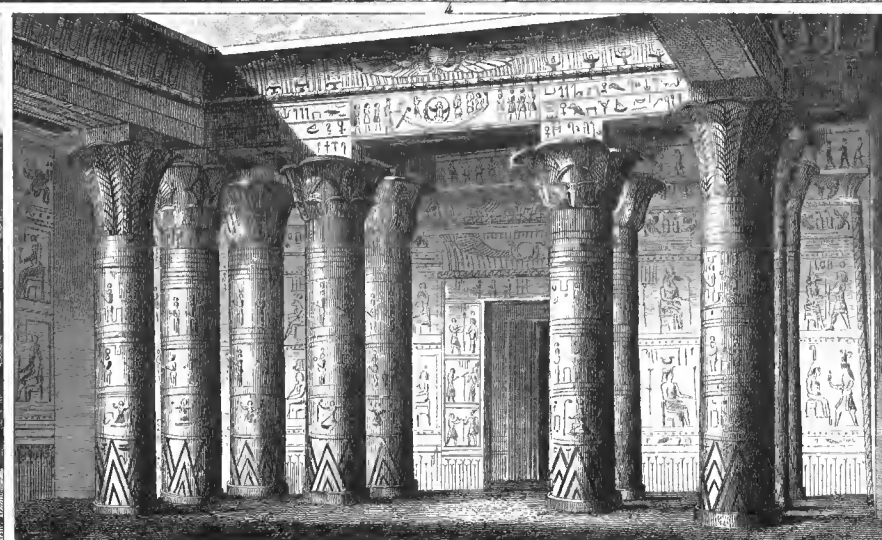
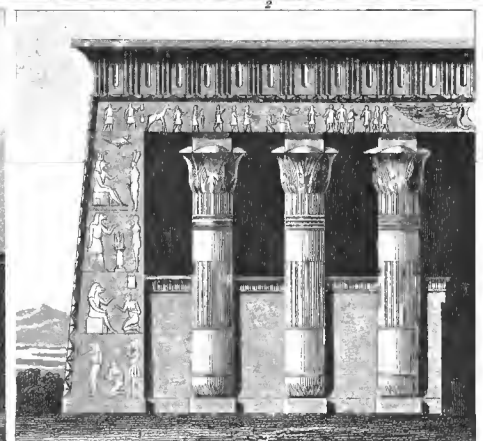
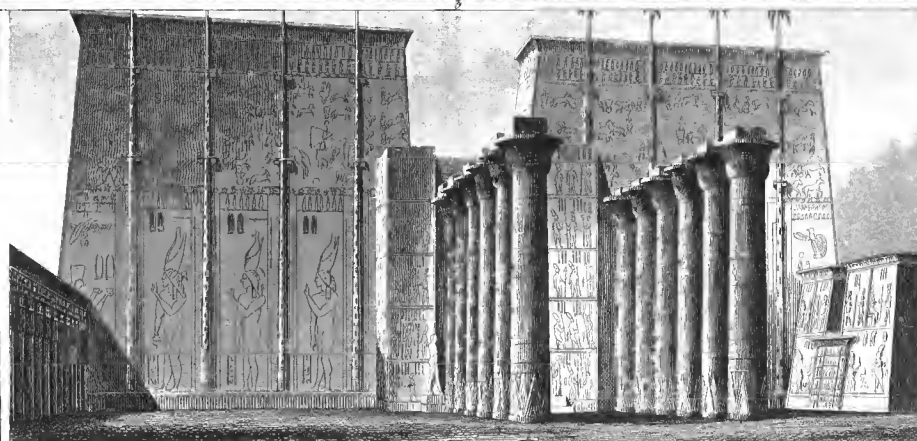
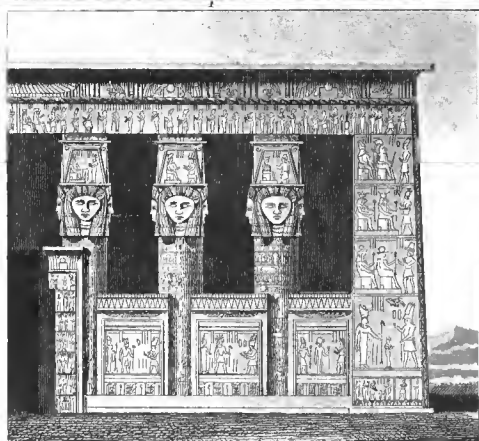
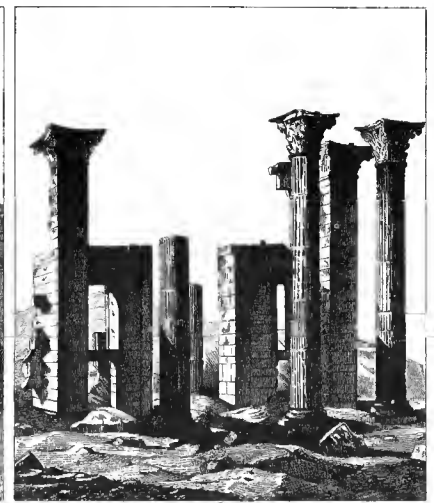
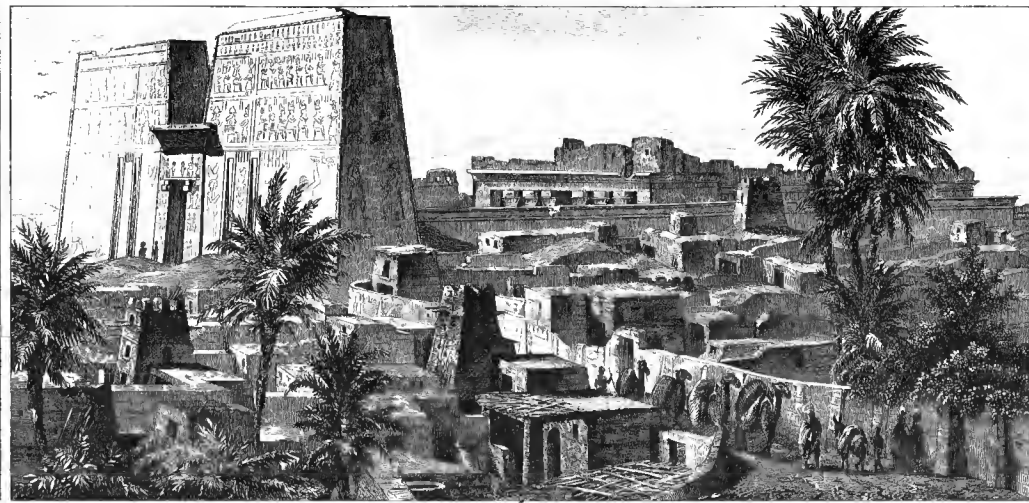
NEW YORK: 1851.
PUBLISHED BY RUDOLPH GARRIGUE,
2 BARCLAY STREET (ASTOR HOUSE).











1

2

3

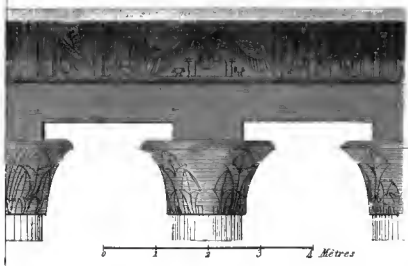
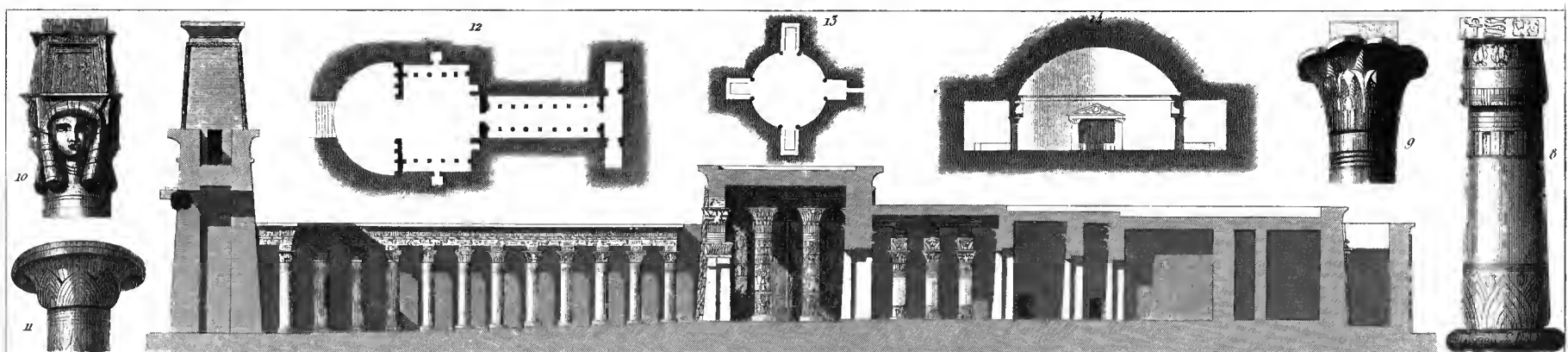


Fig. 5

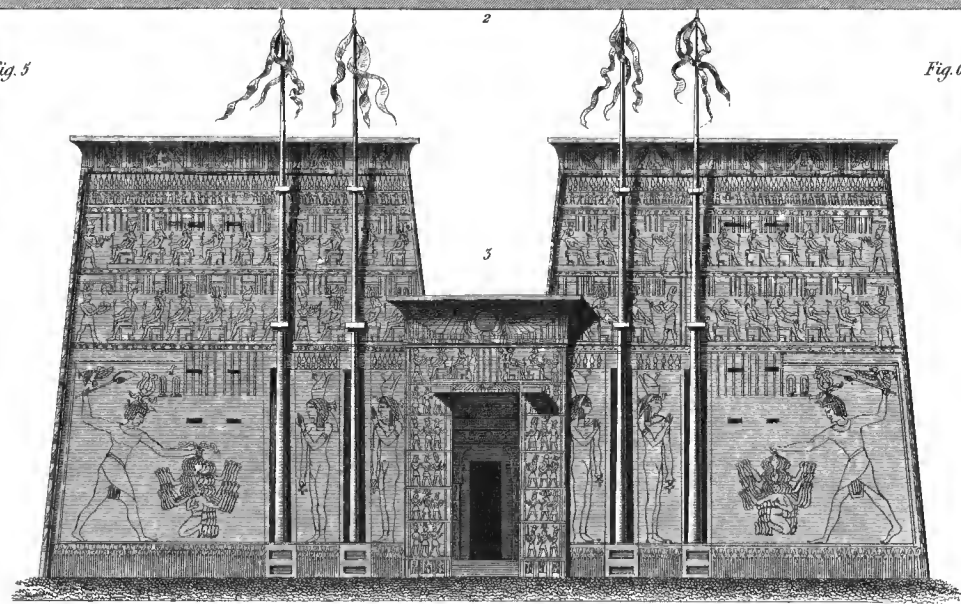
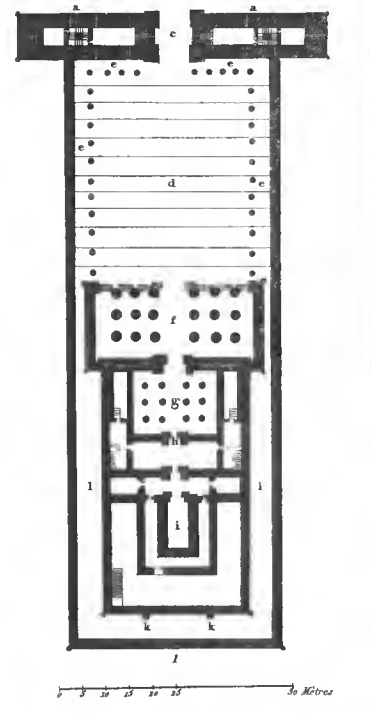
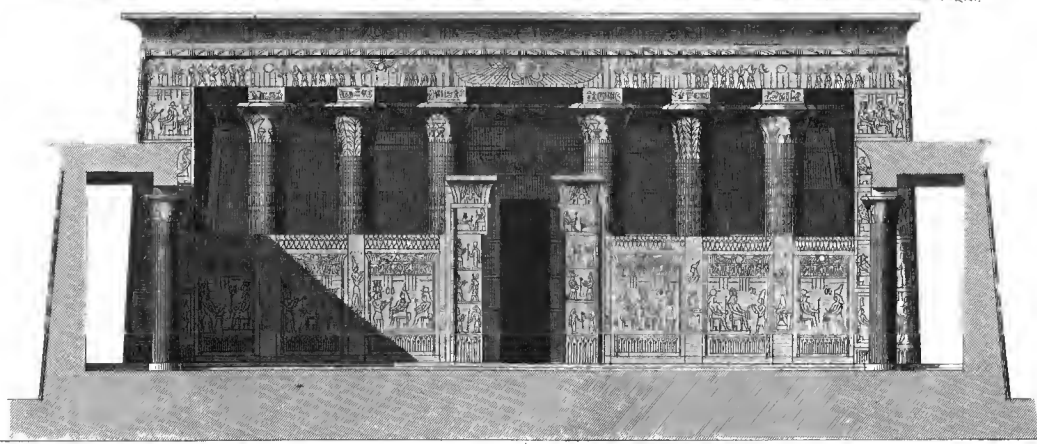
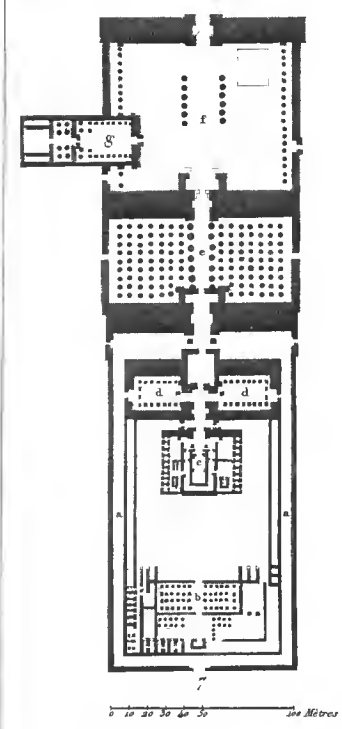
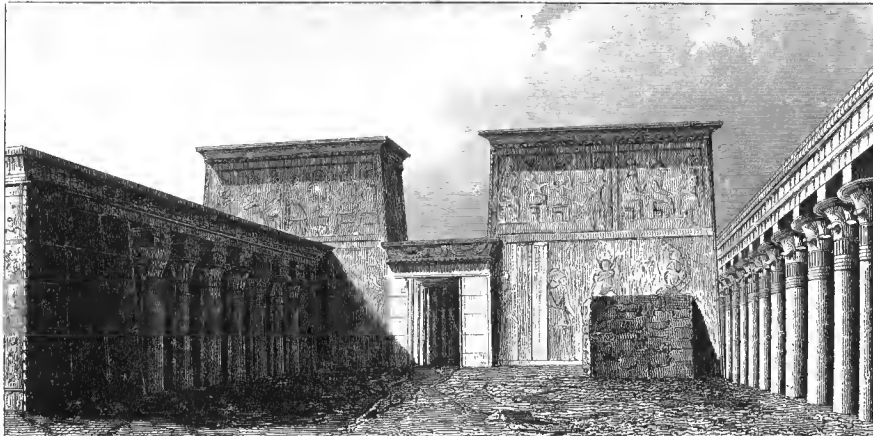
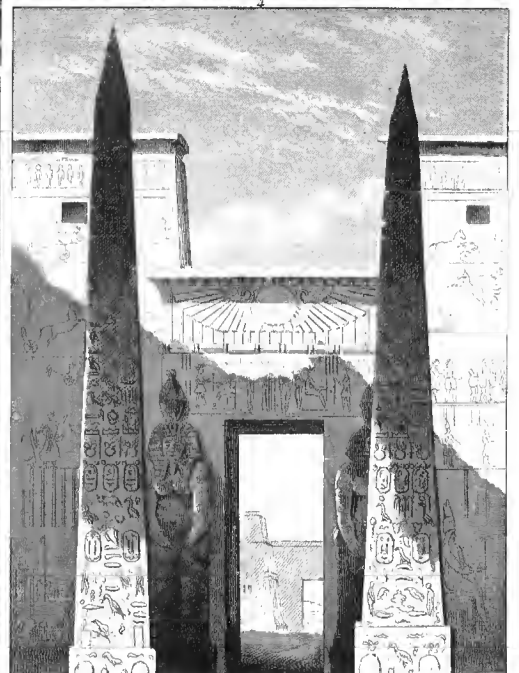
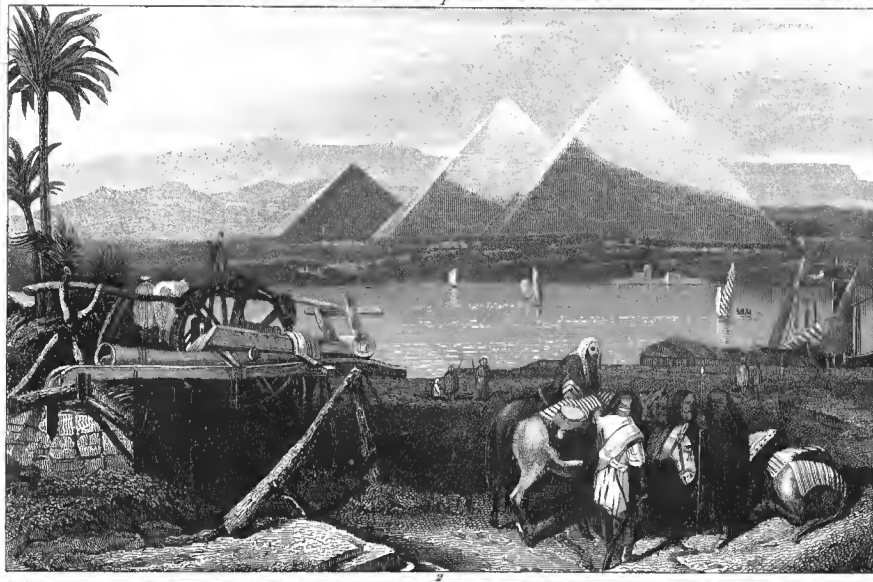
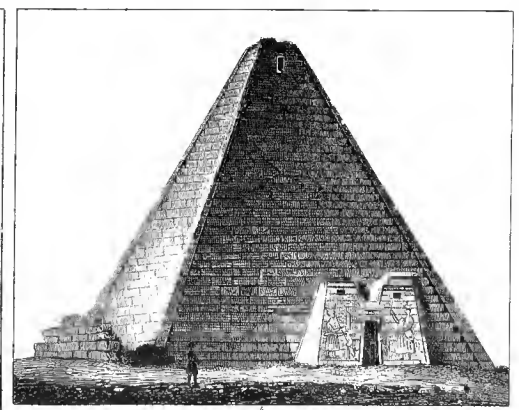
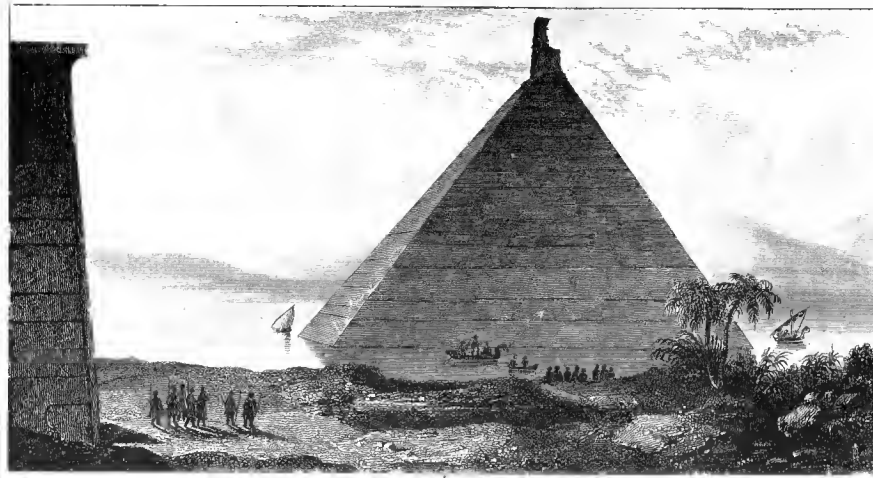
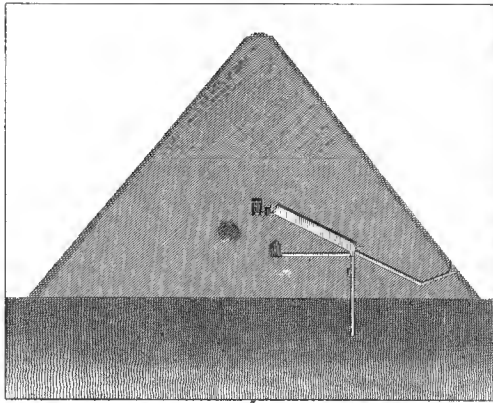


Fig. 6



Maasstab für Figur 2. 0 5 10 20 30 40 Metres

Maasstab für Figur 3 & 4. 0 5 10 15 20 25 30 Metres



6

9

5

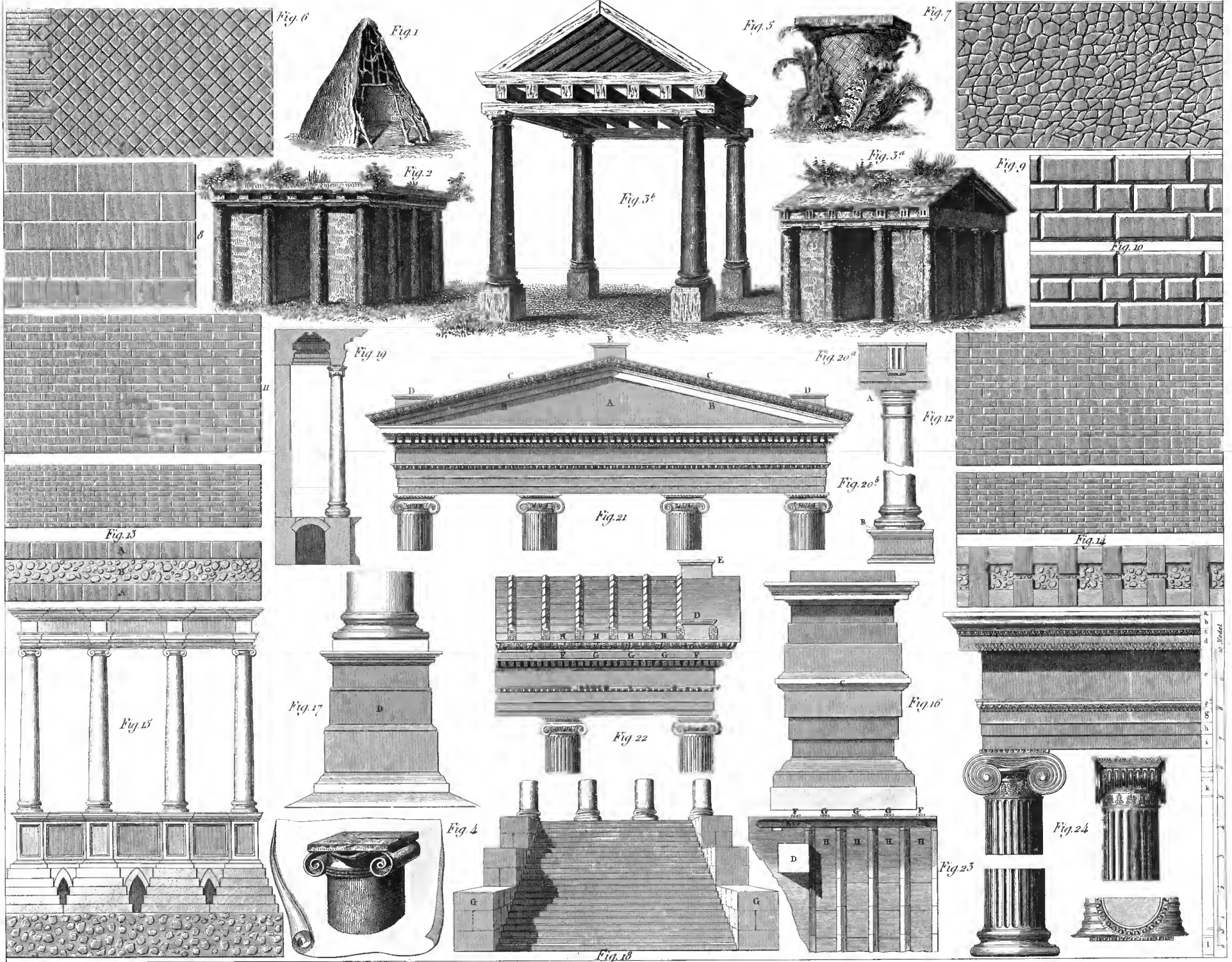


Fig. 6

Fig. 1

Fig. 5

Fig. 7

Fig. 2

Fig. 3^a

Fig. 3^b

Fig. 9

8

Fig. 10

Fig. 19

Fig. 20^a

Fig. 12

Fig. 21

Fig. 20^b

Fig. 13

Fig. 14

Fig. 15

Fig. 17

Fig. 22

Fig. 16

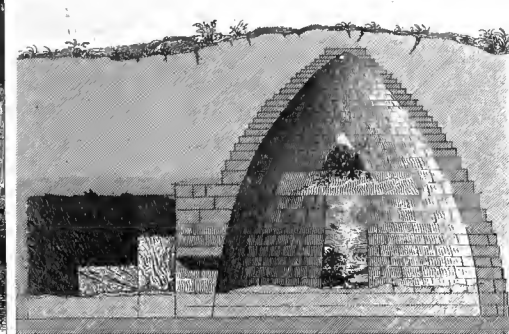
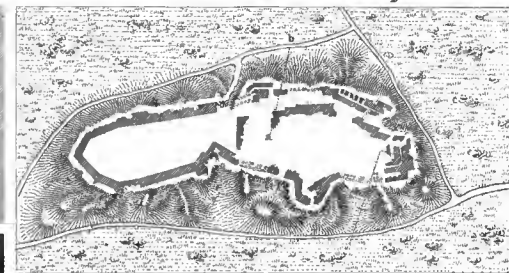
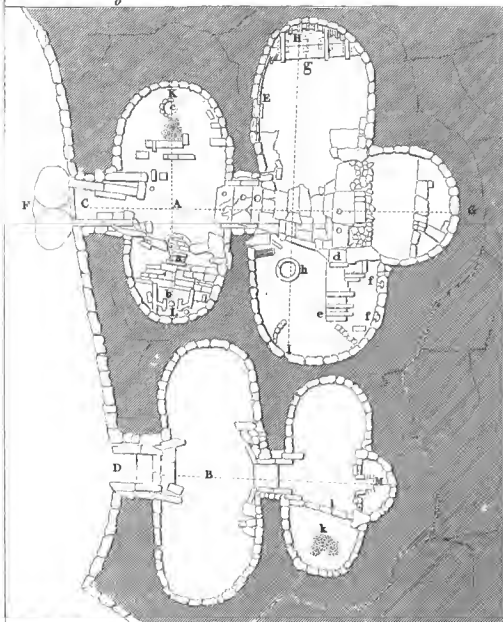
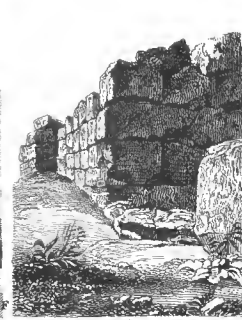
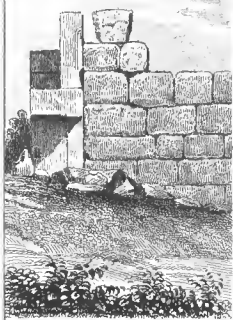
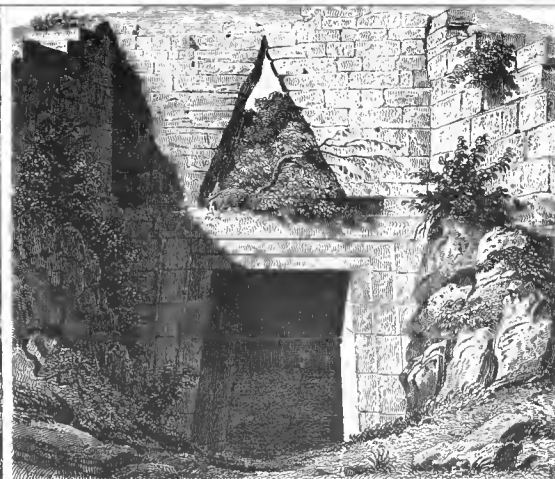
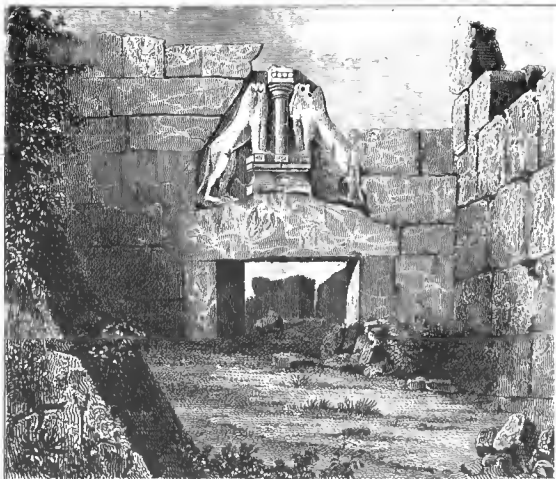
Fig. 4

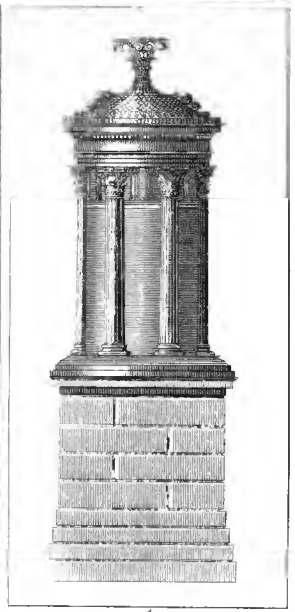
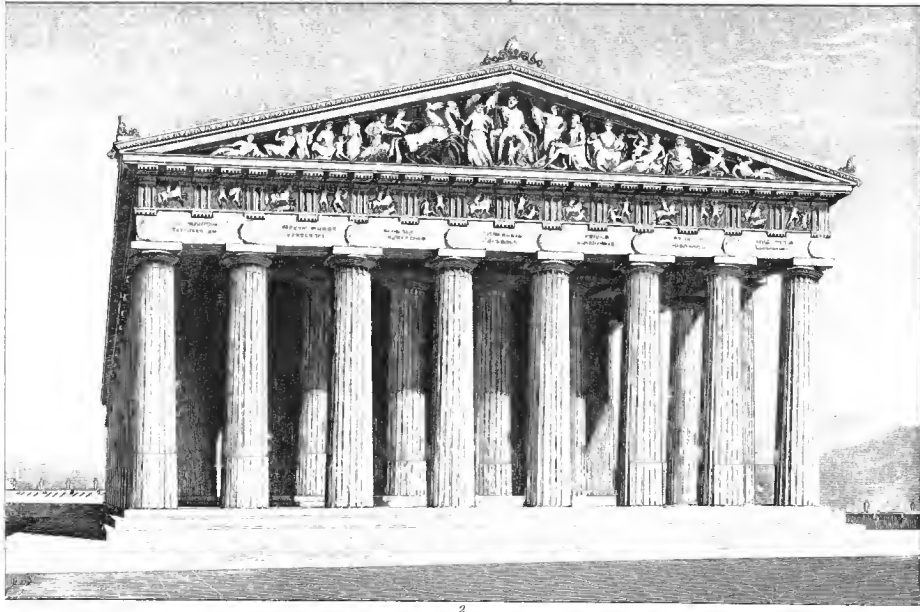
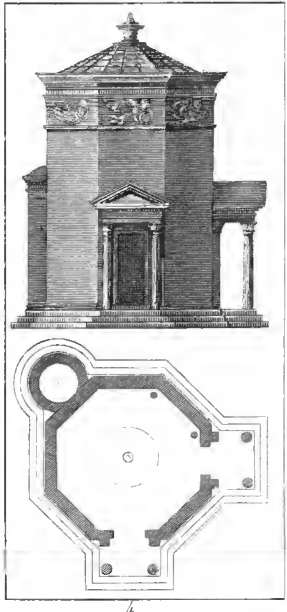
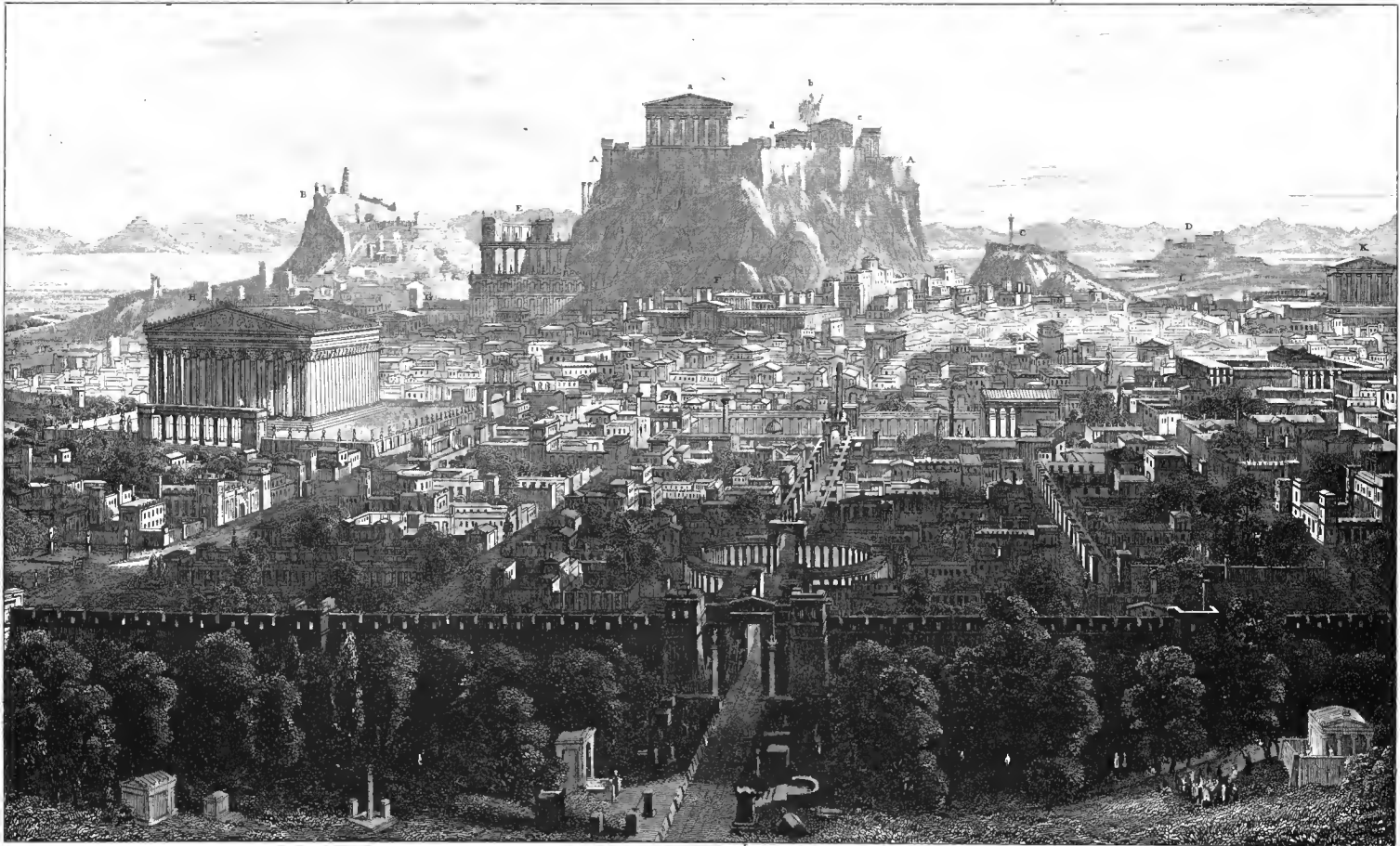
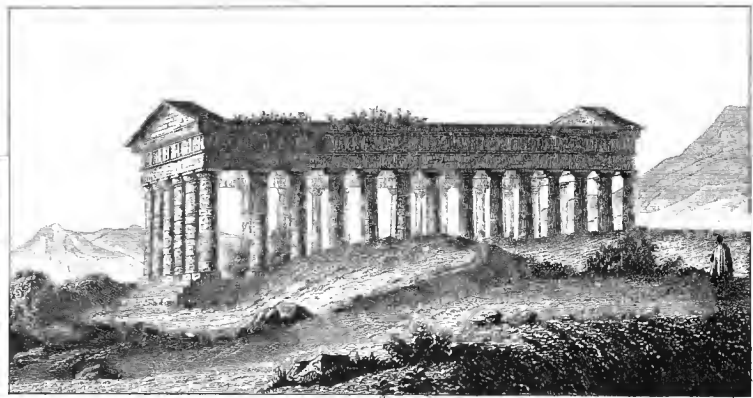
Fig. 18

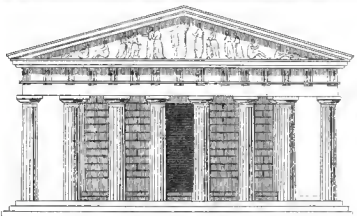
Fig. 23

Fig. 24

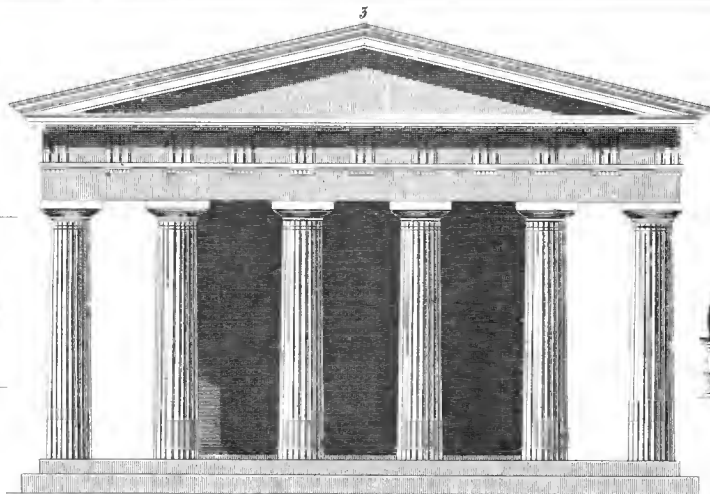
1
2
3
4
5
6
7
8
9
10
11
12
13
14
15
16
17
18
19
20
21
22
23
24
25
26
27
28
29
30
31
32
33
34
35
36
37
38
39
40
41
42
43
44
45
46
47
48
49
50
51
52
53
54
55
56
57
58
59
60
61
62
63
64
65
66
67
68
69
70
71
72
73
74
75
76
77
78
79
80
81
82
83
84
85
86
87
88
89
90
91
92
93
94
95
96
97
98
99
100



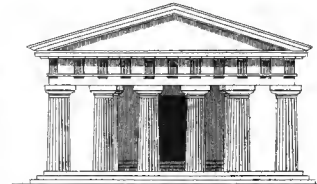




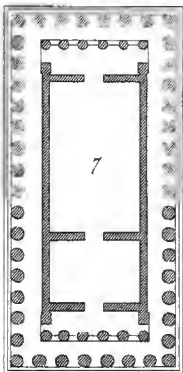
6



b 1 2 3 4 5 6 7 8 9 10 20 30 40 50 60 Engl. Fuss



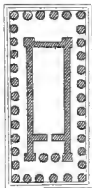
20



7



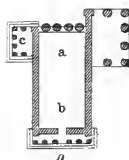
4



5



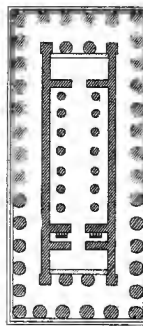
8



a

b

9



21



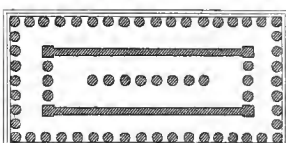
24



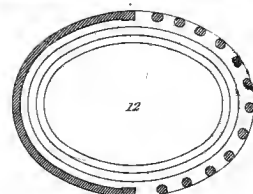
1



17



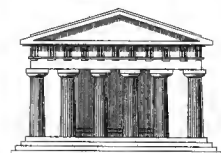
25



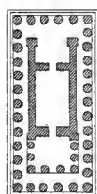
12



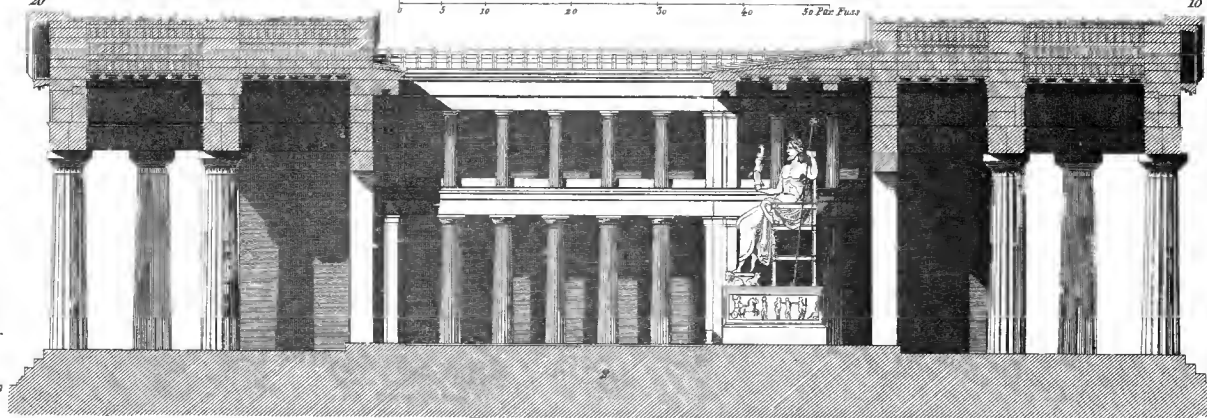
26



18

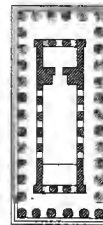


27



3

0 5 10 20 30 40 50 60 80



19



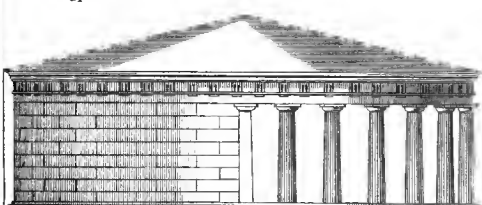
15



25



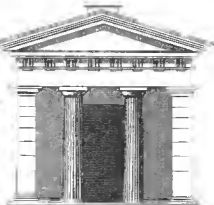
14



11



13



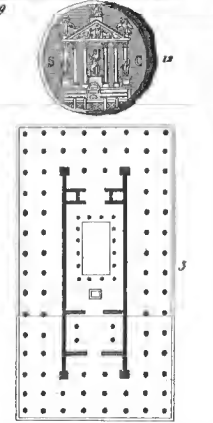
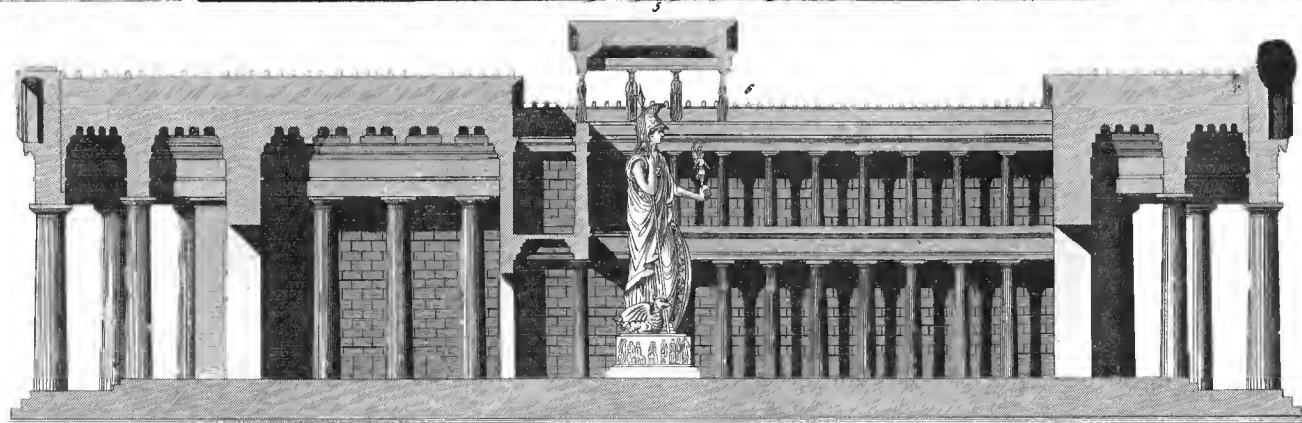
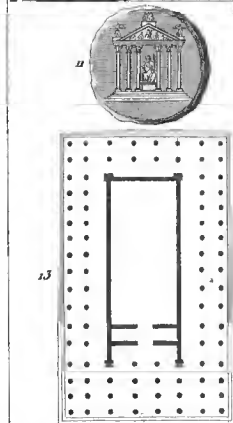
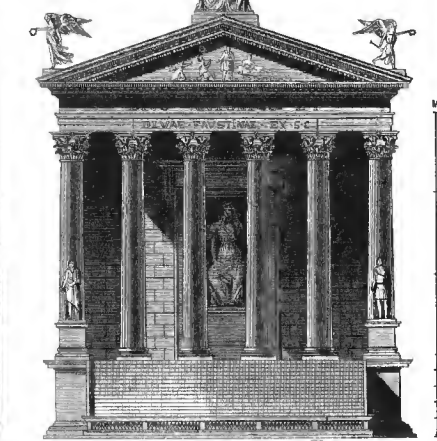
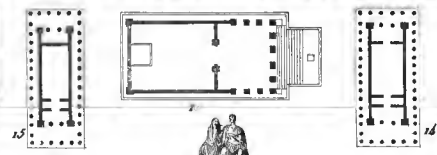
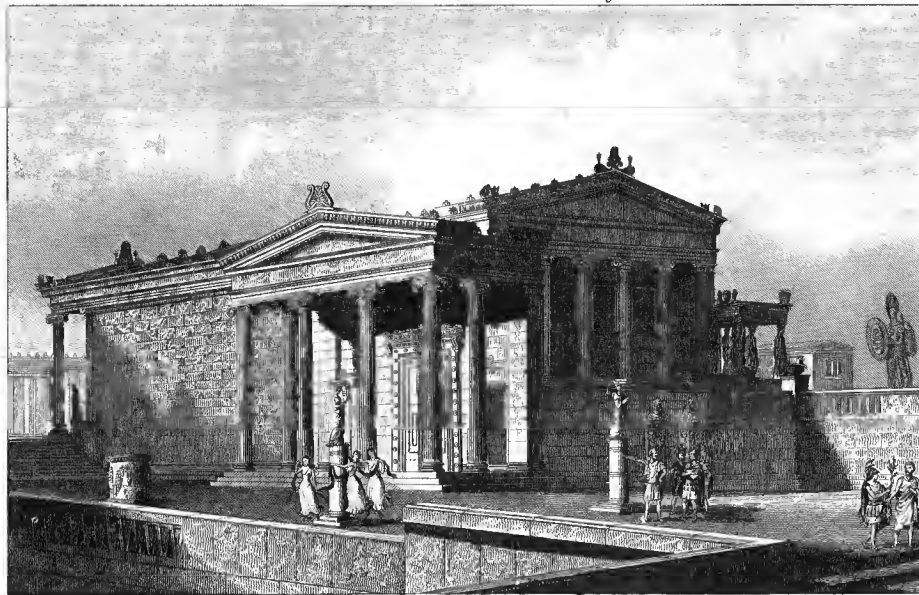
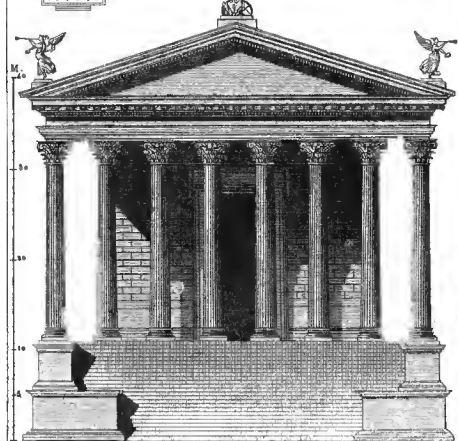
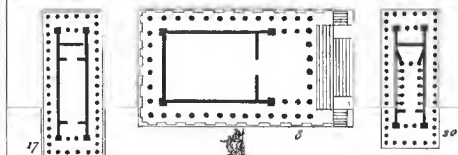
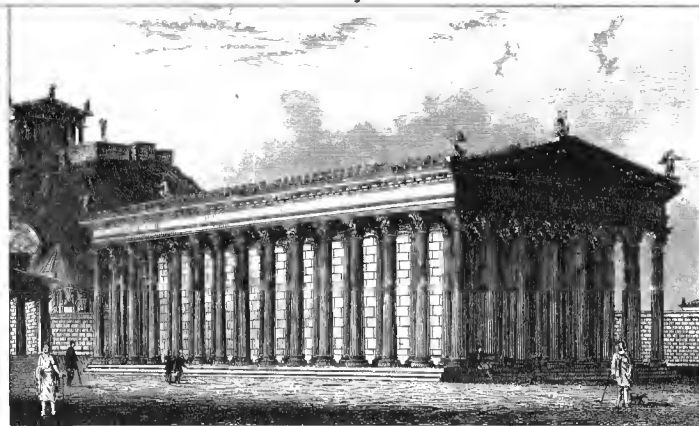
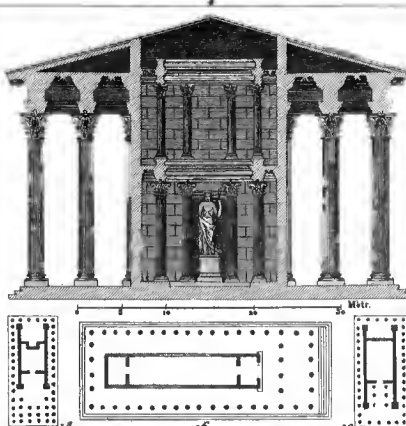
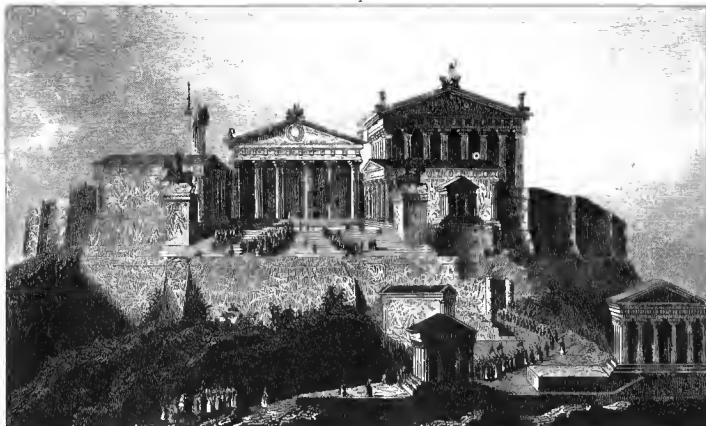
16

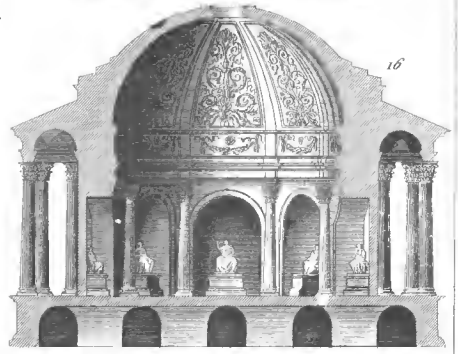
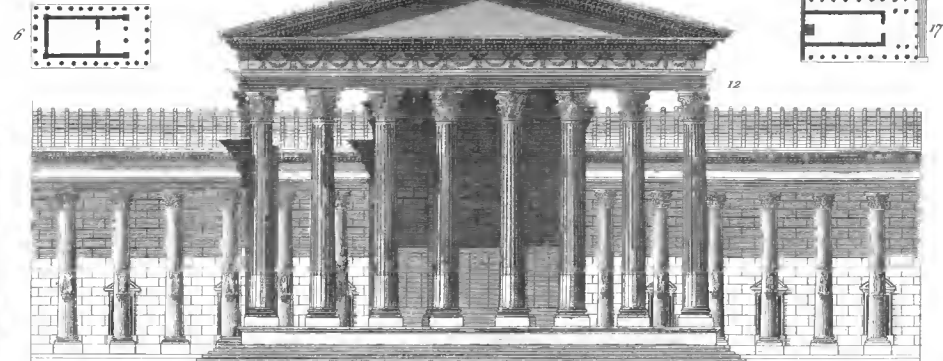
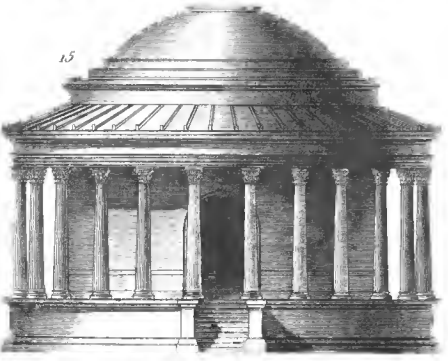
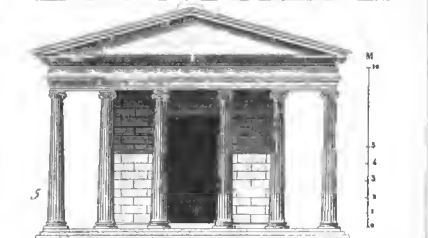
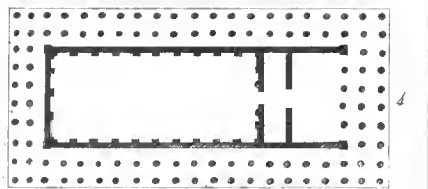
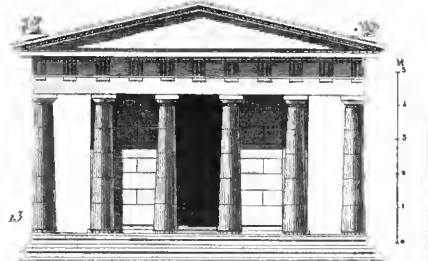
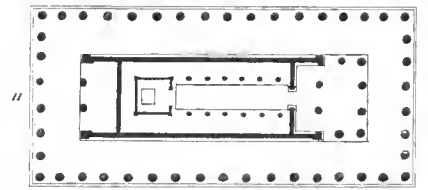
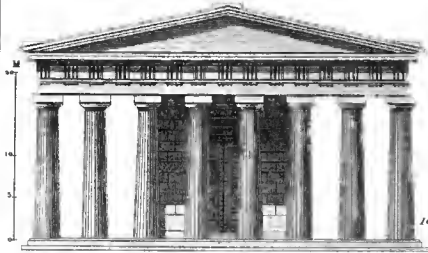
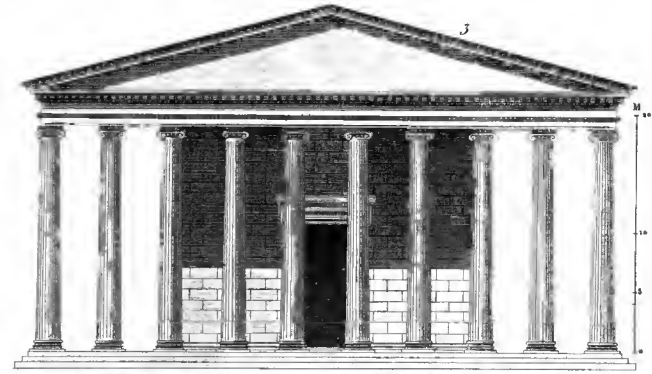
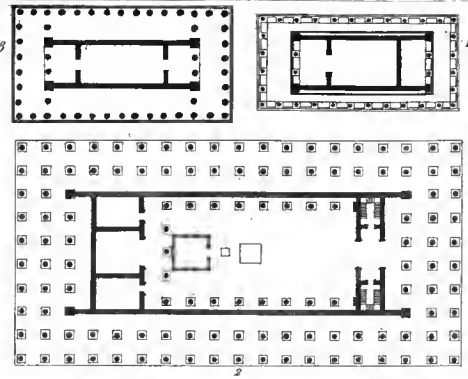
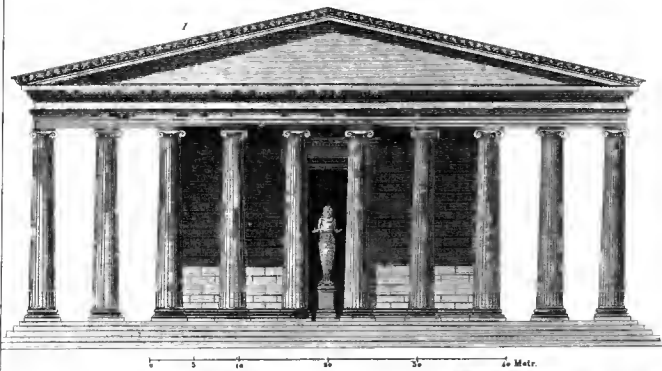


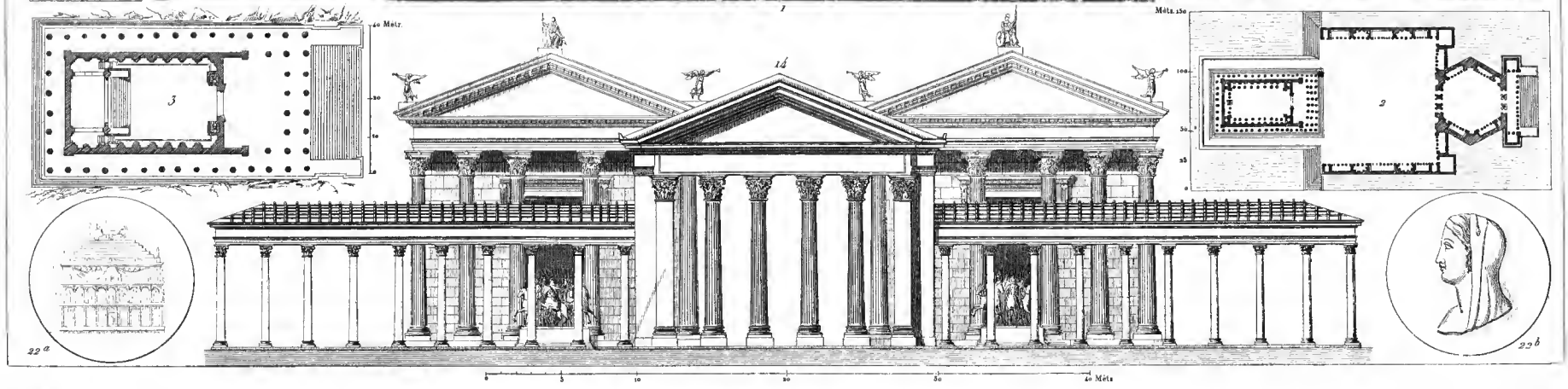
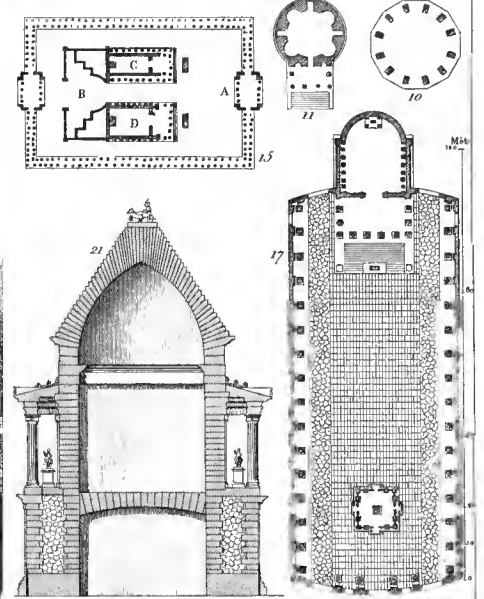
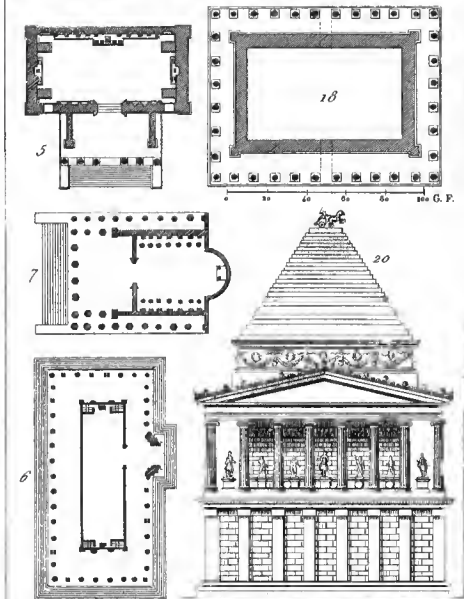
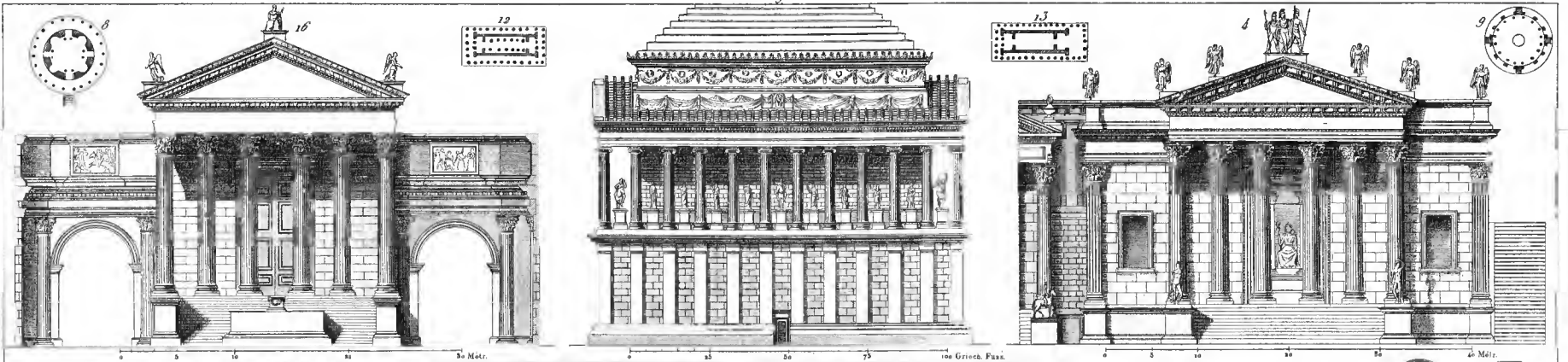
22



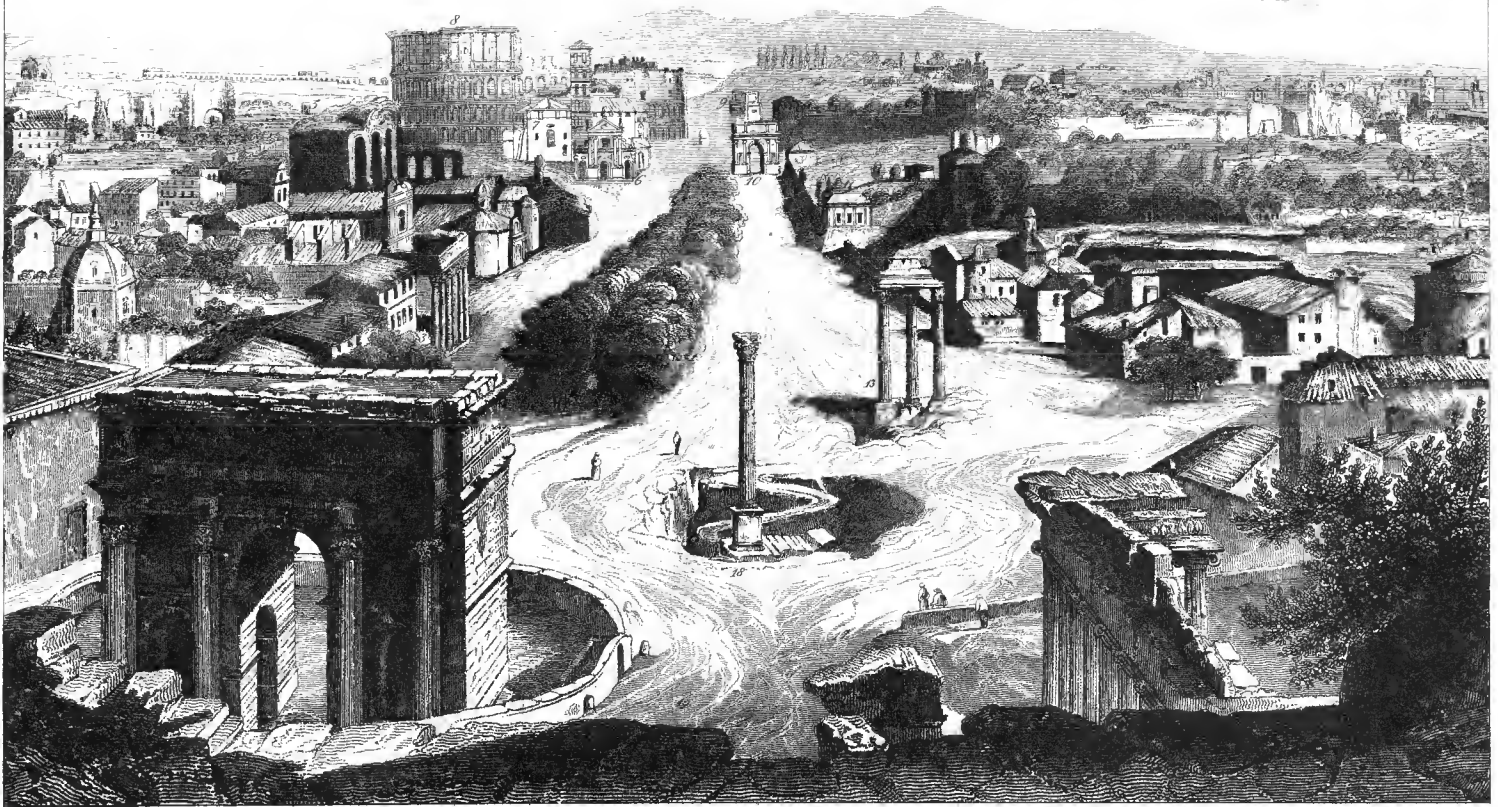
10



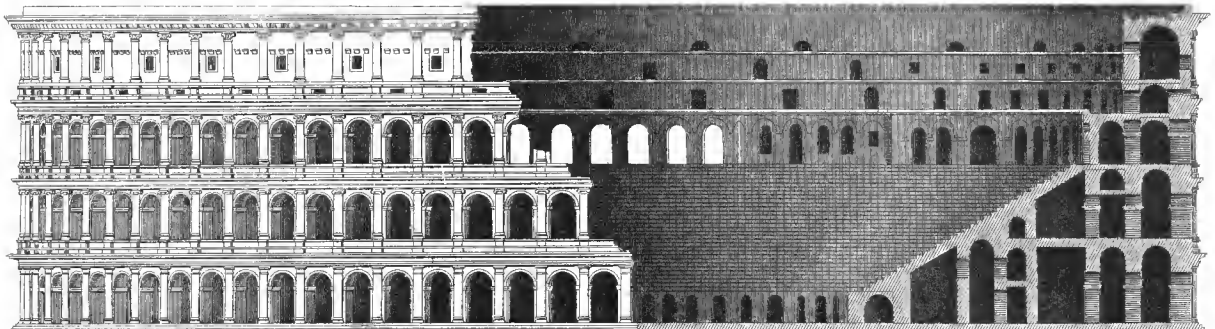




1

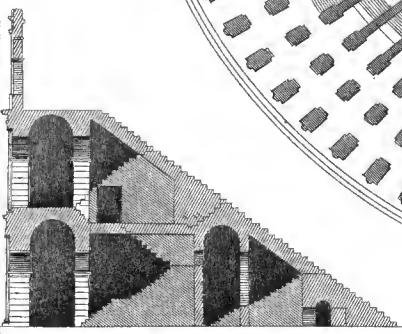
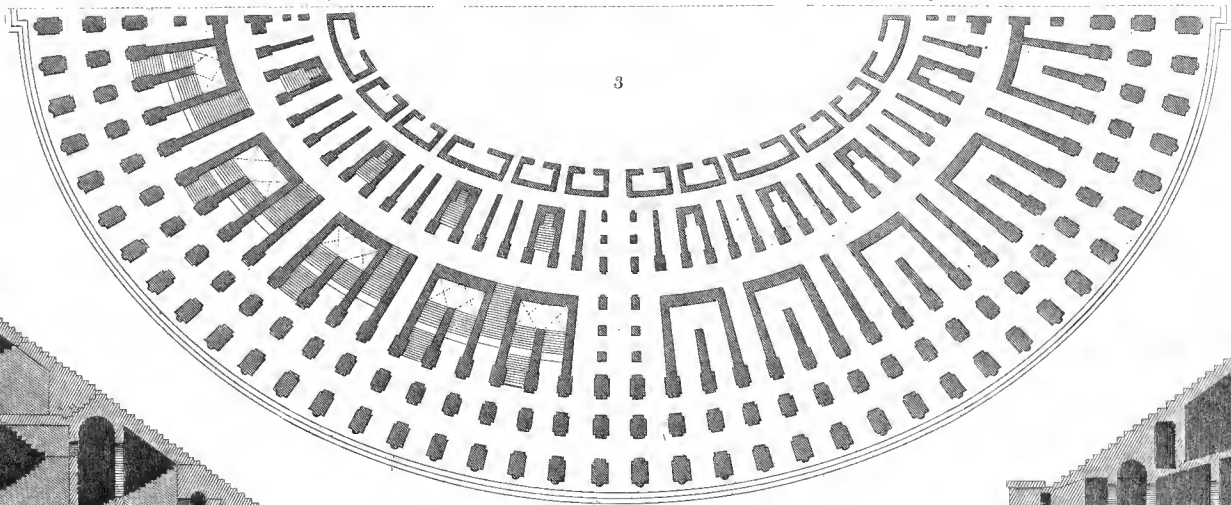


2

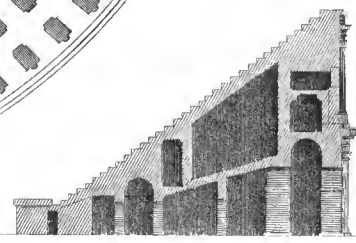


100 200 300 Engl. Fuss.

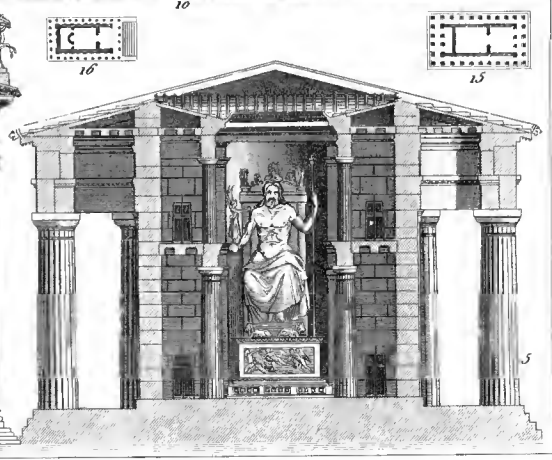
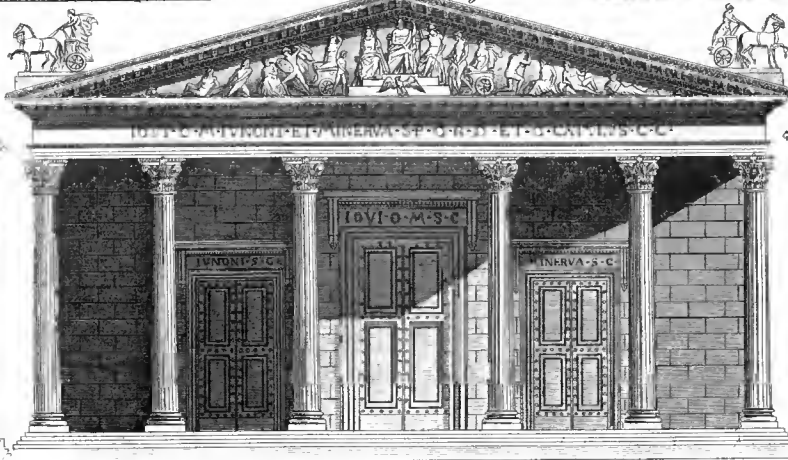
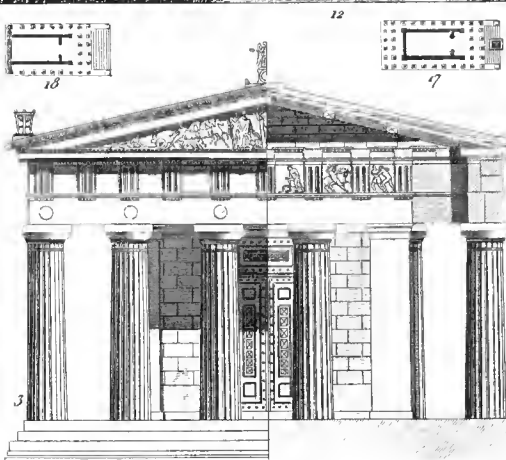
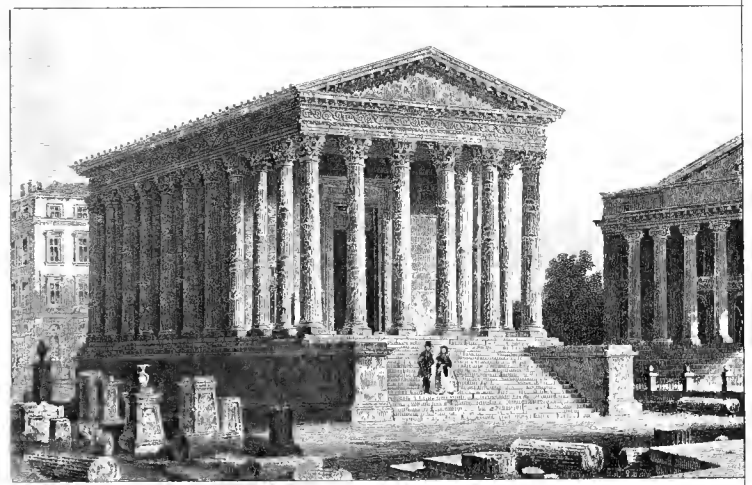
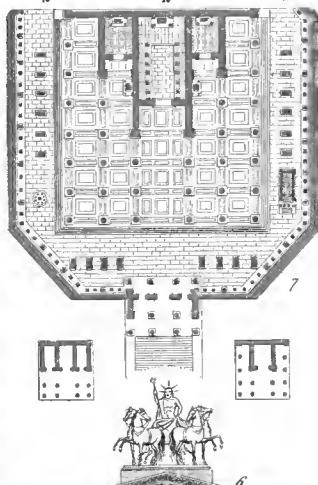
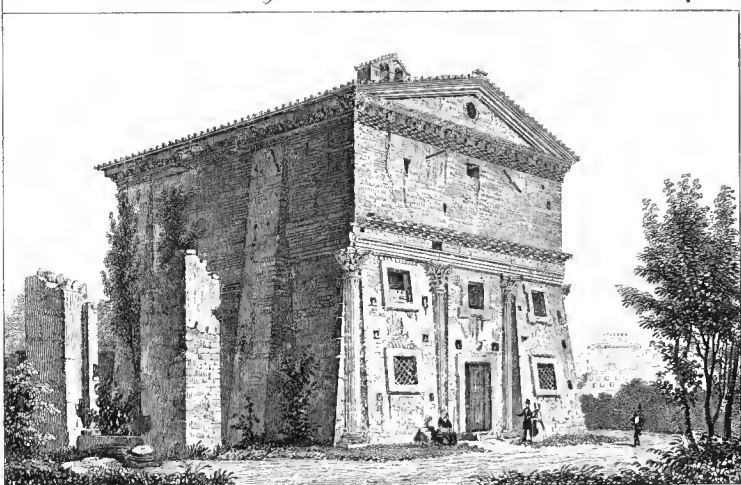
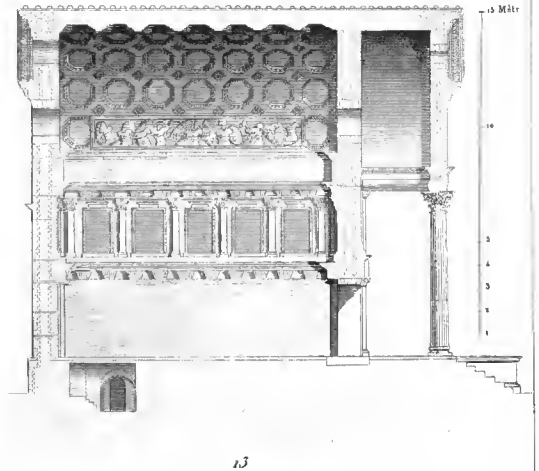
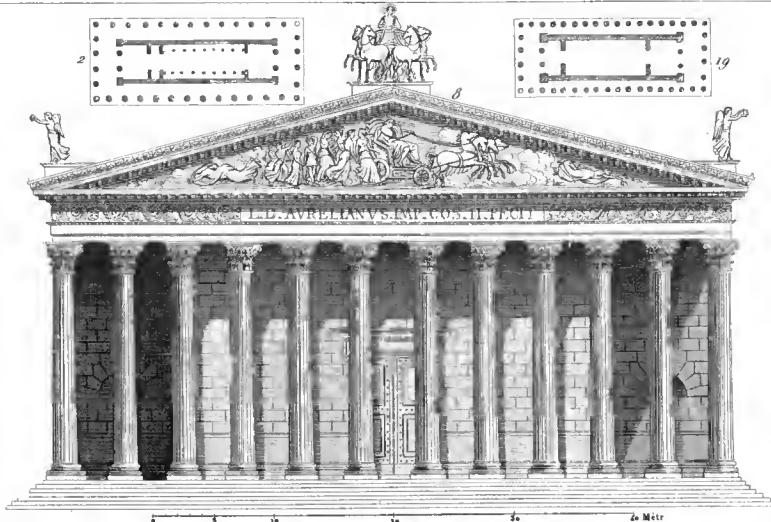
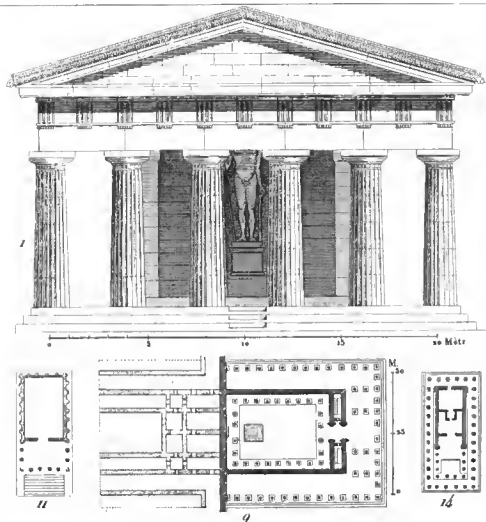
3

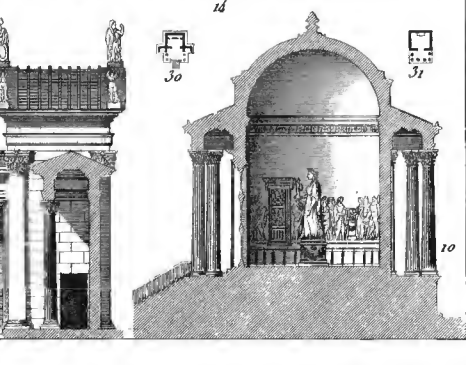
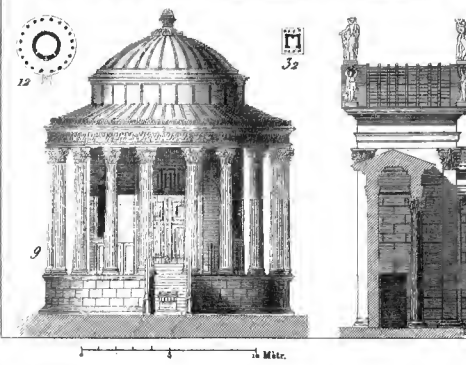
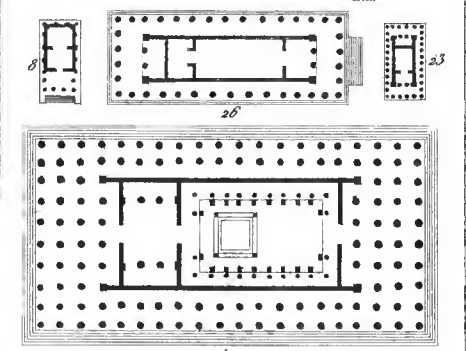
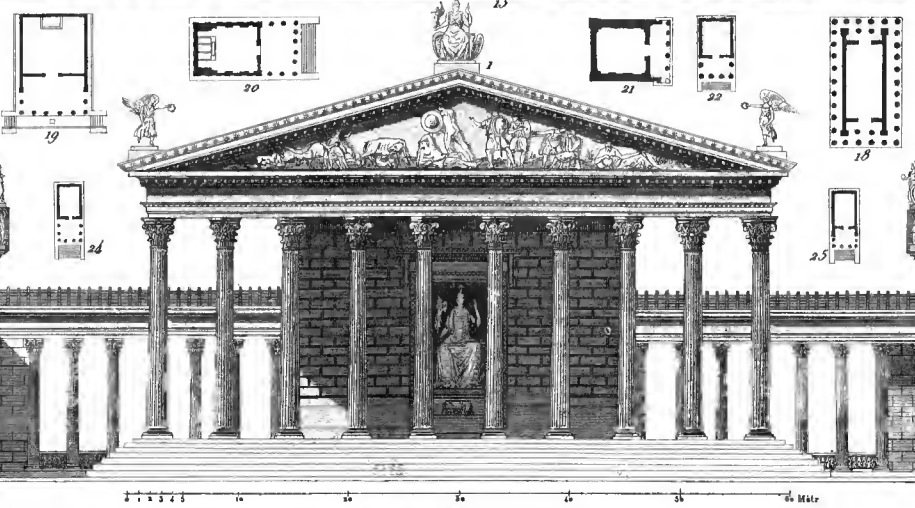
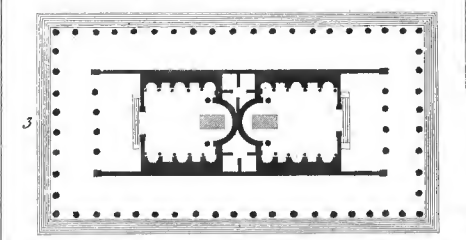
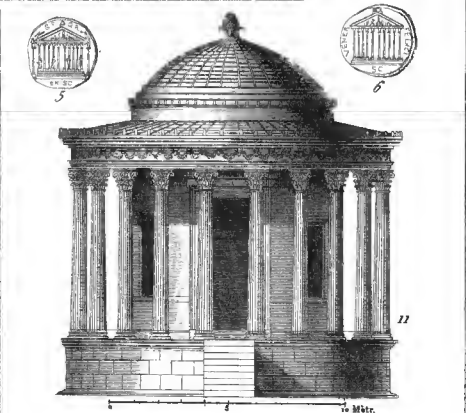
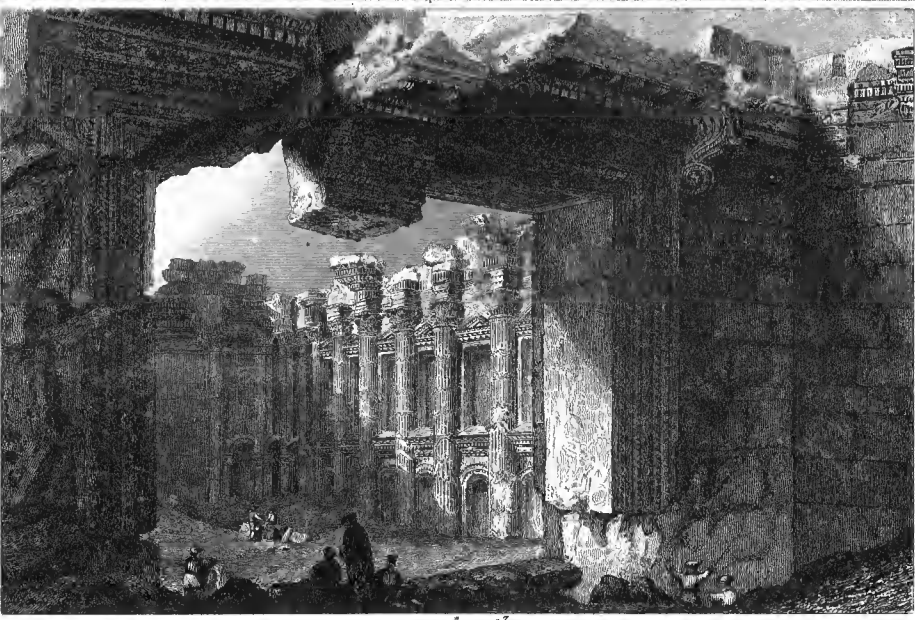
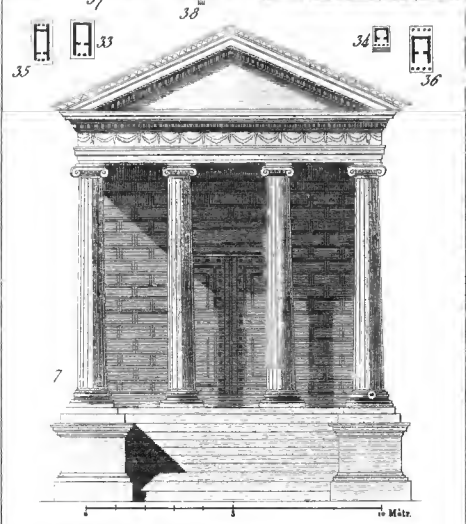
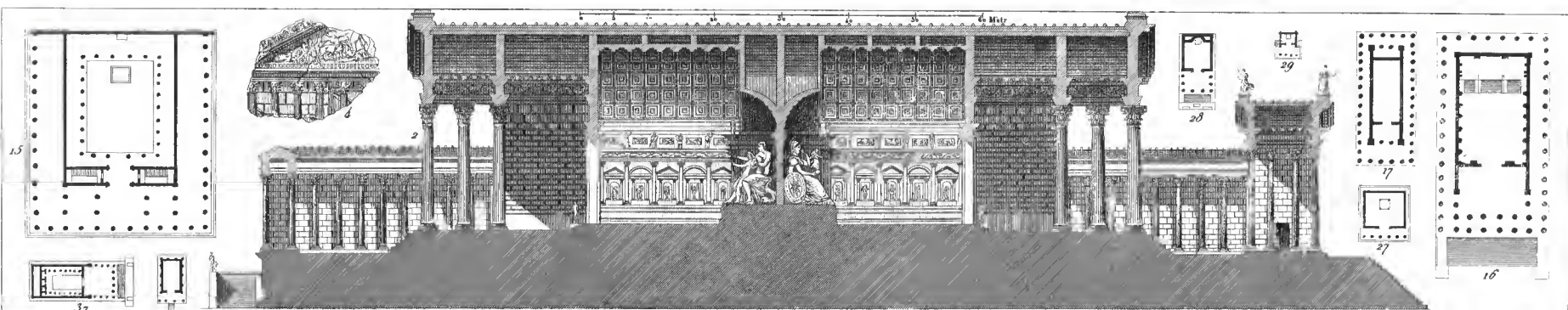


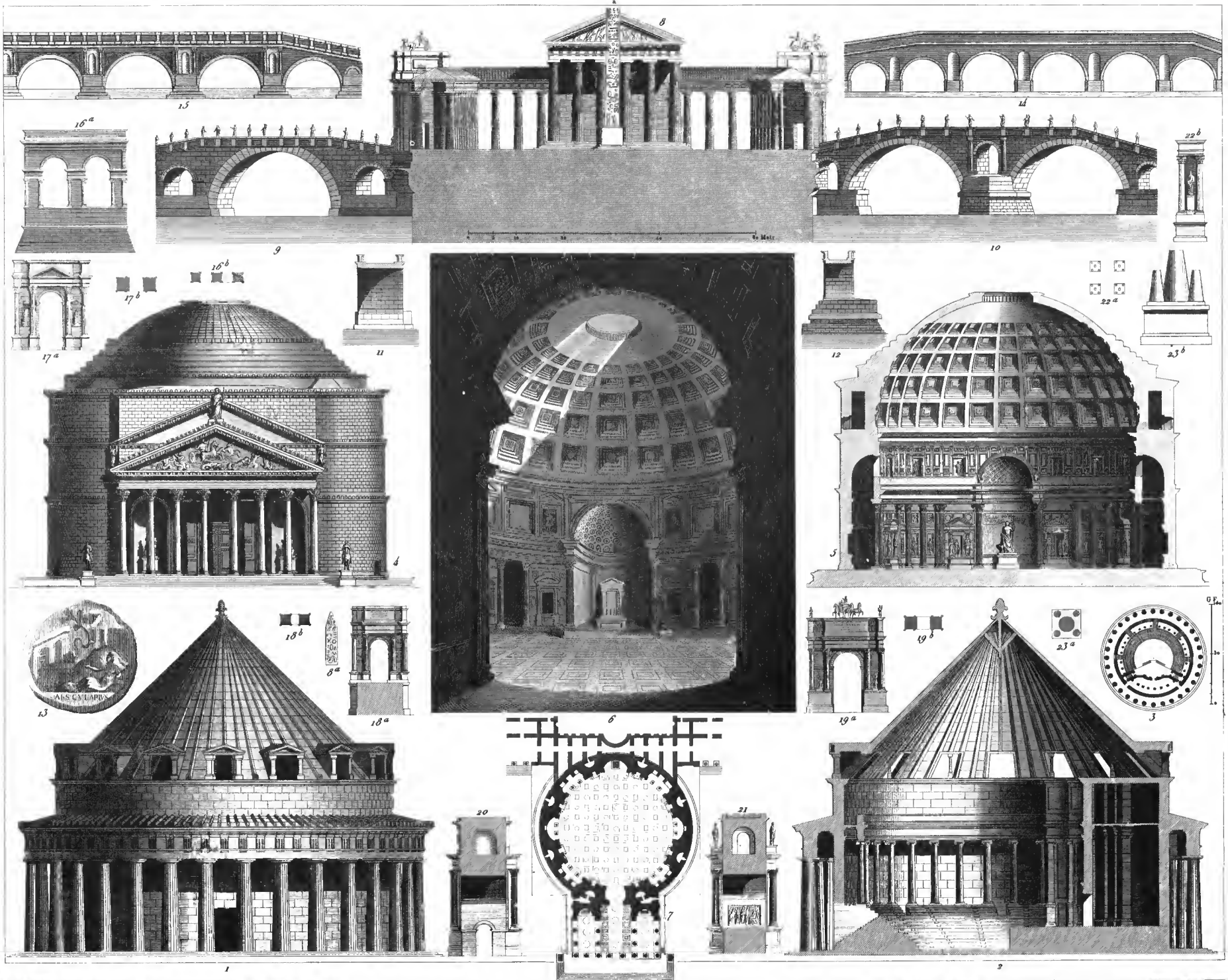
4



5







Heck. 1871

Maassstab für Fig. 1 & 2

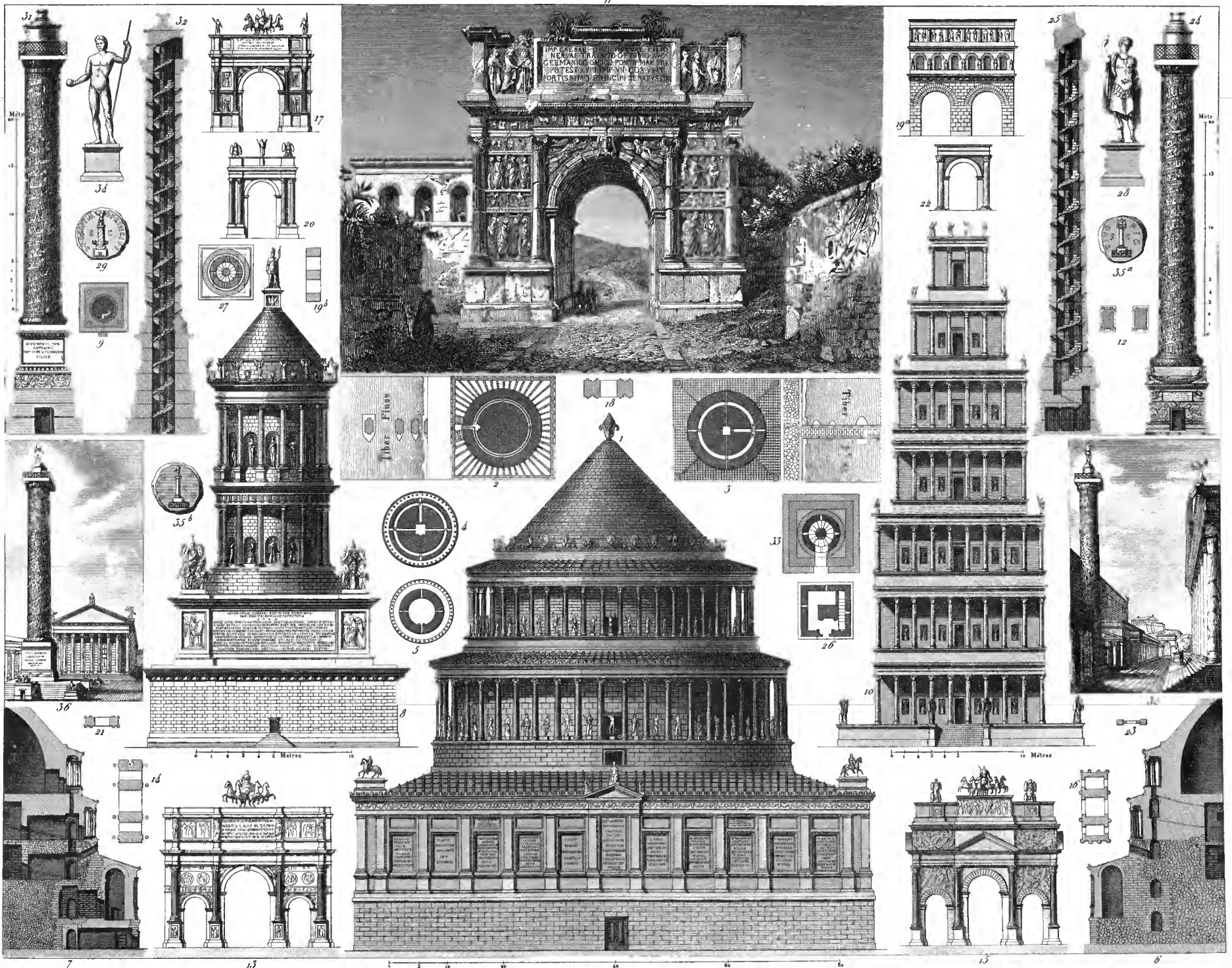
6 Griech. Fuss

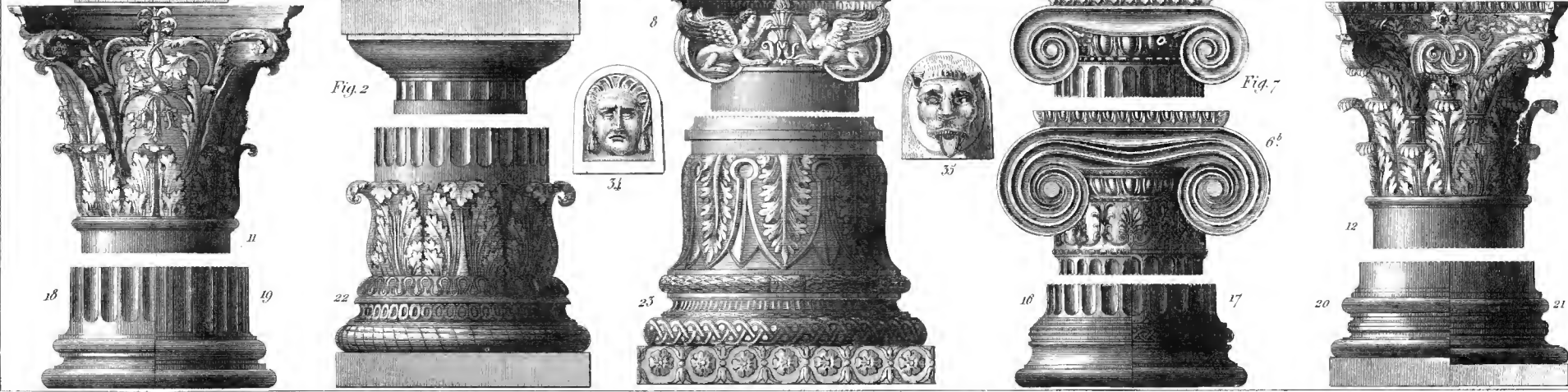
6 Metres

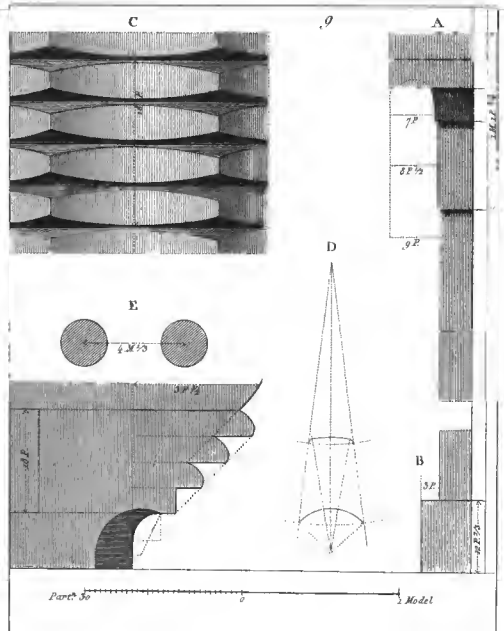
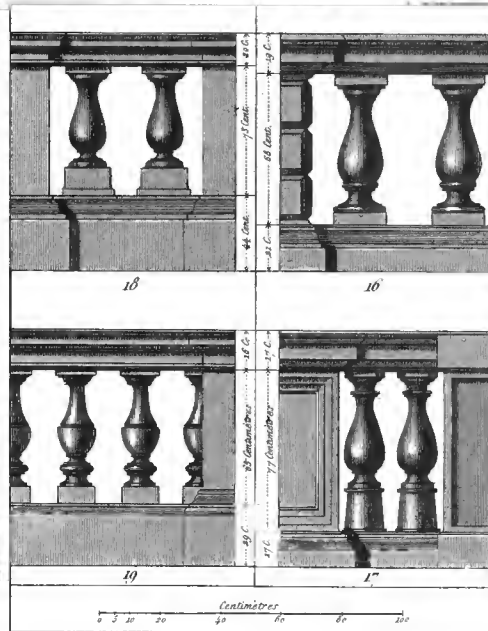
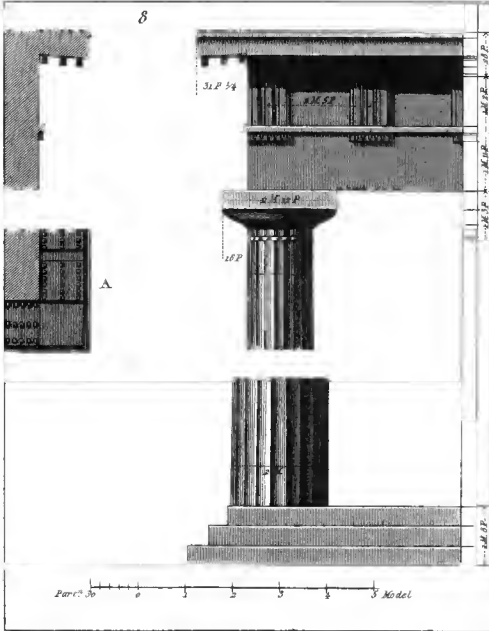
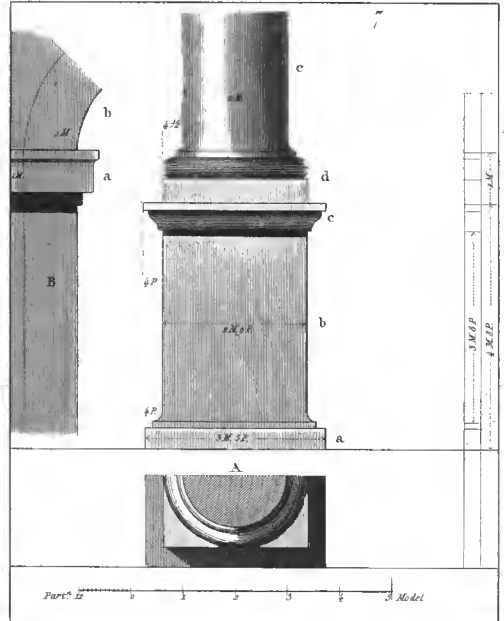
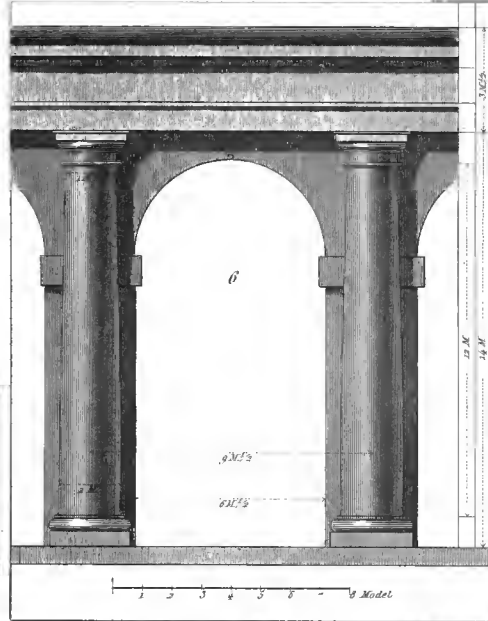
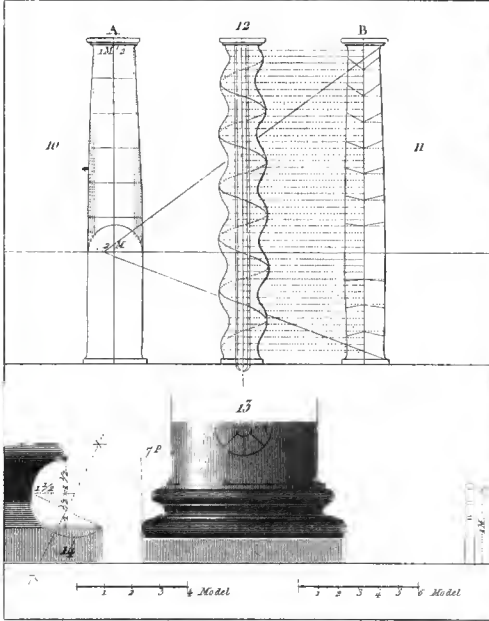
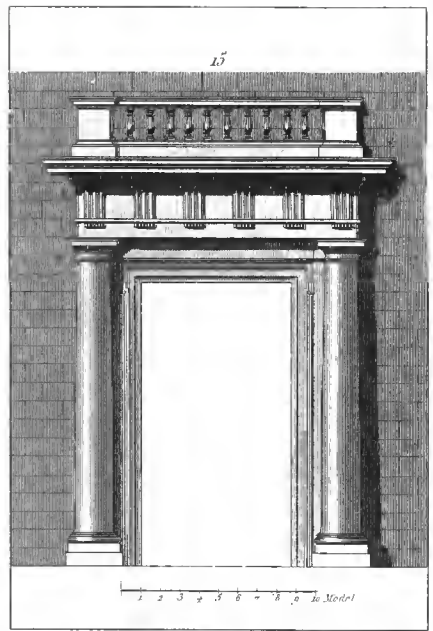
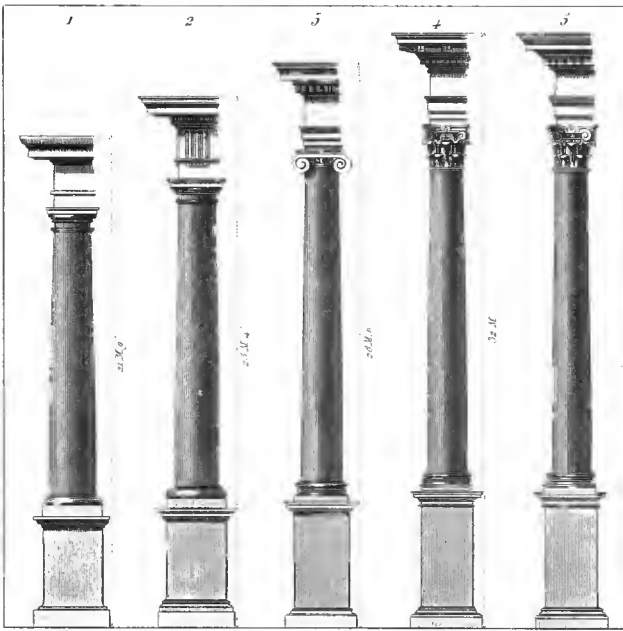
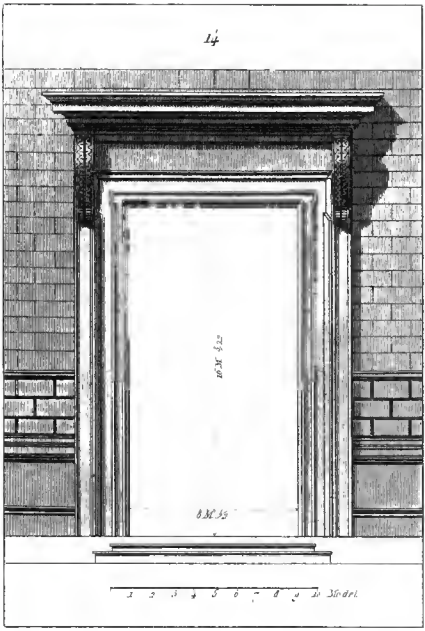
Maassstab für Fig. 3 & 4

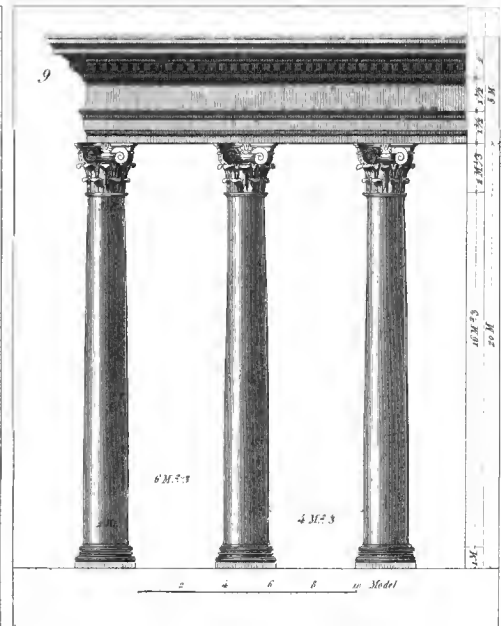
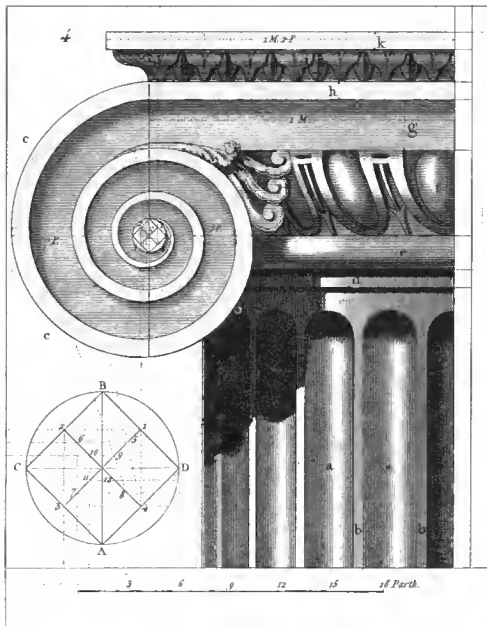
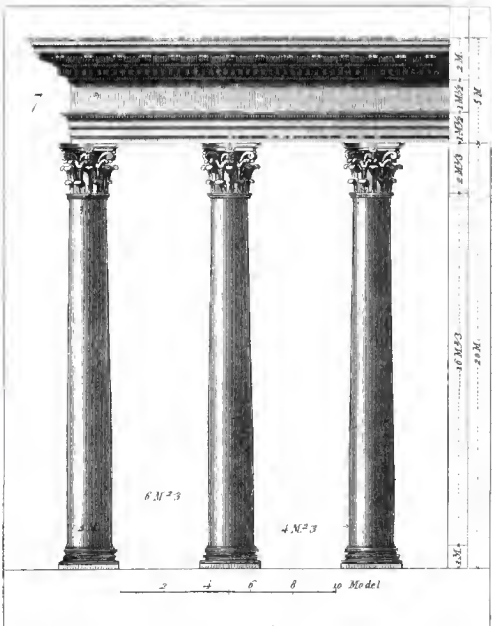
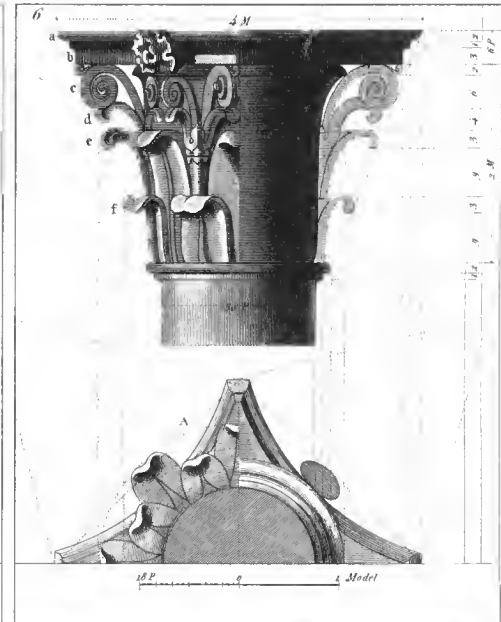
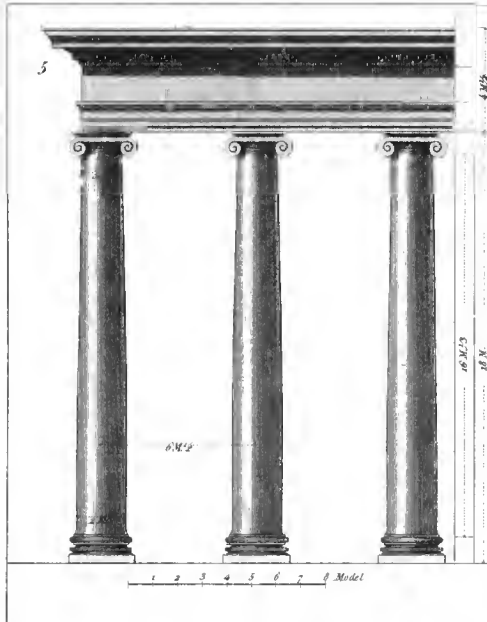
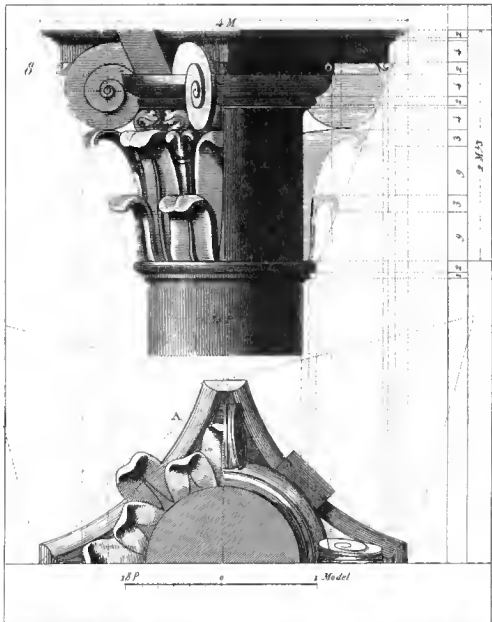
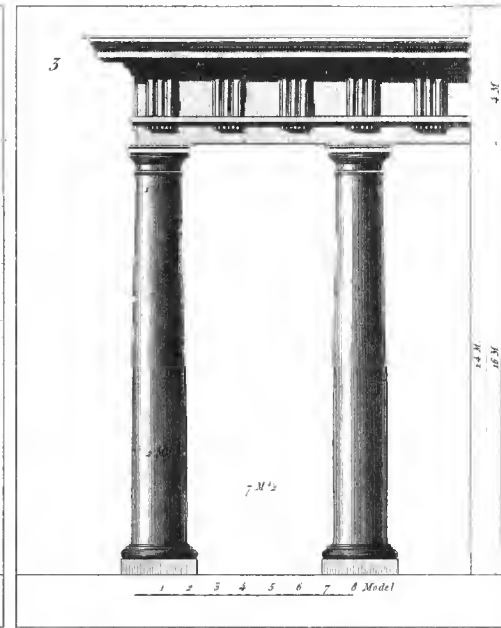
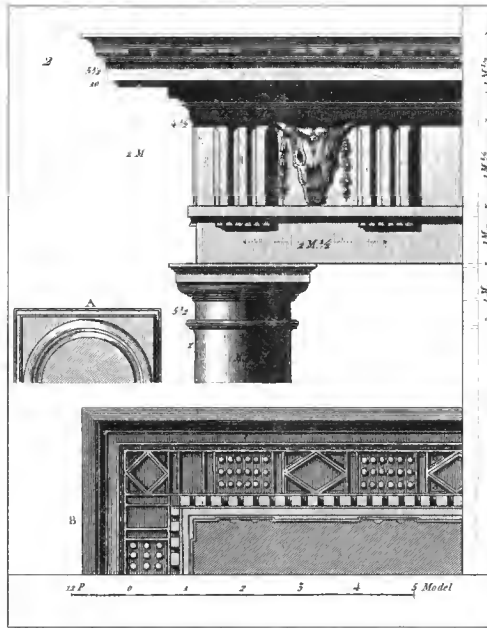
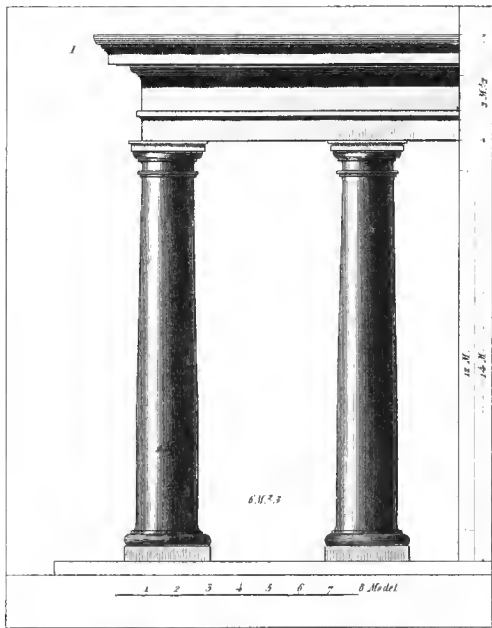
6 Metres

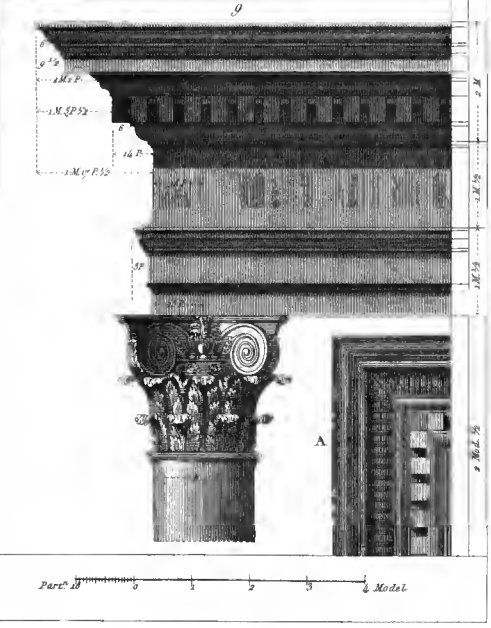
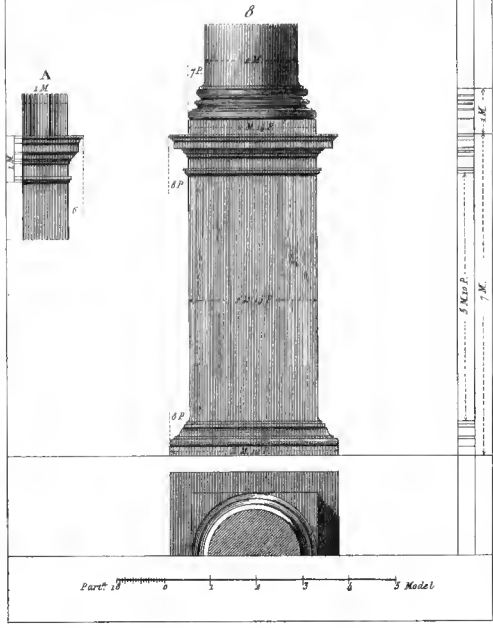
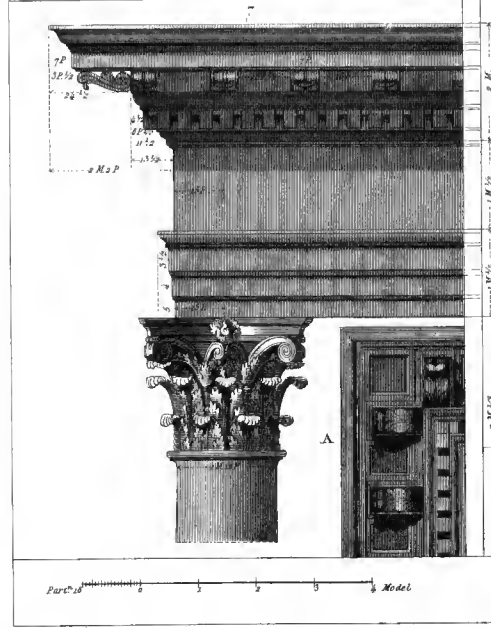
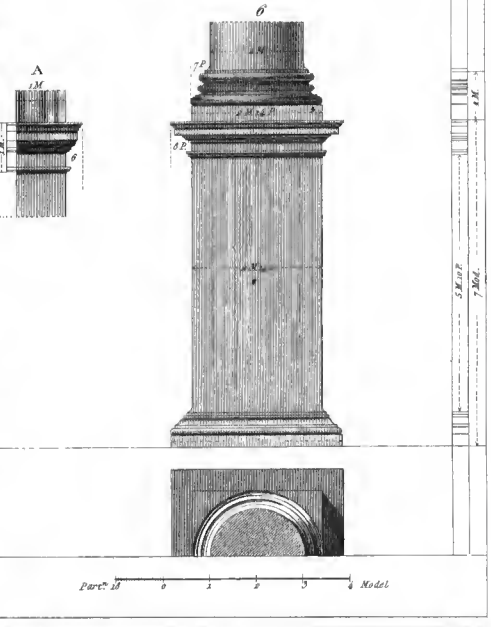
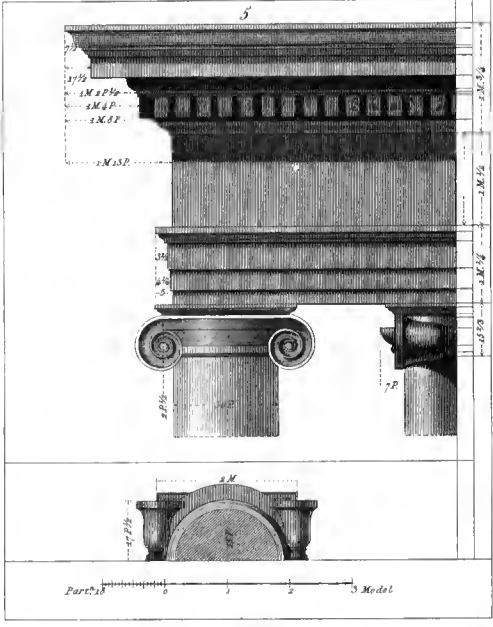
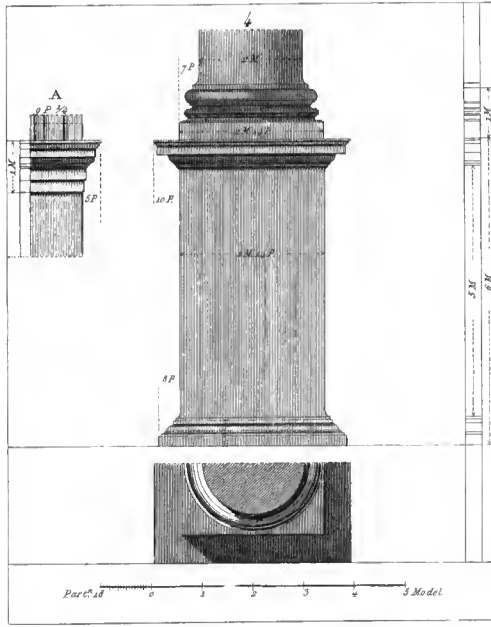
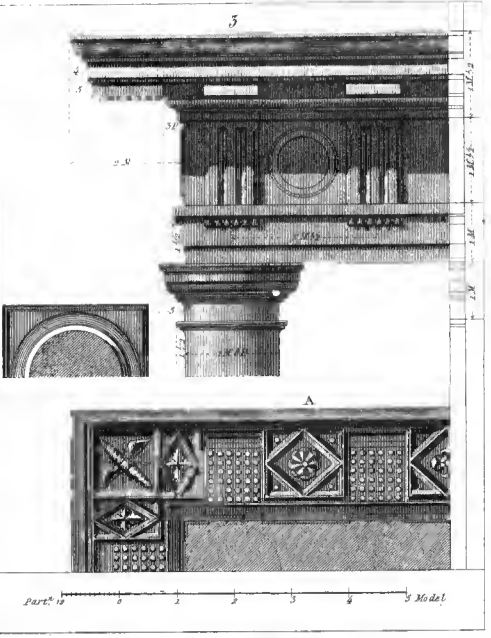
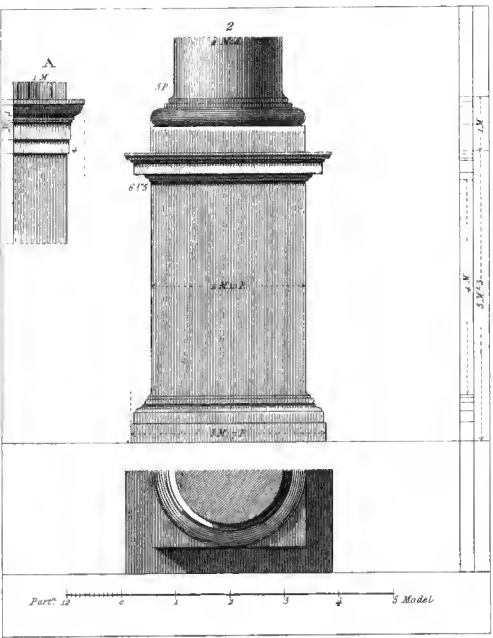
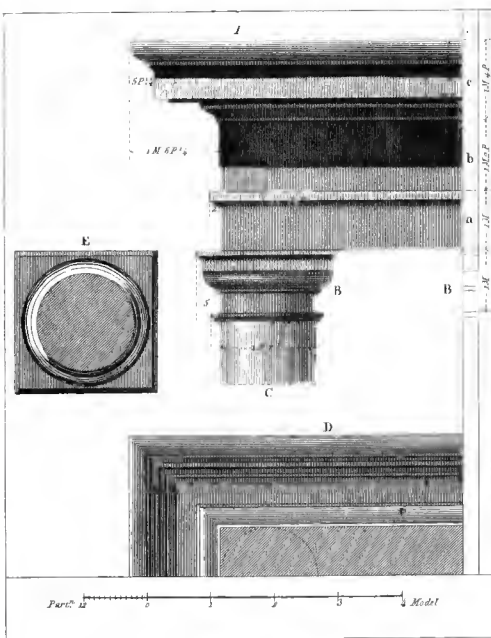
Henry Winkles sculp

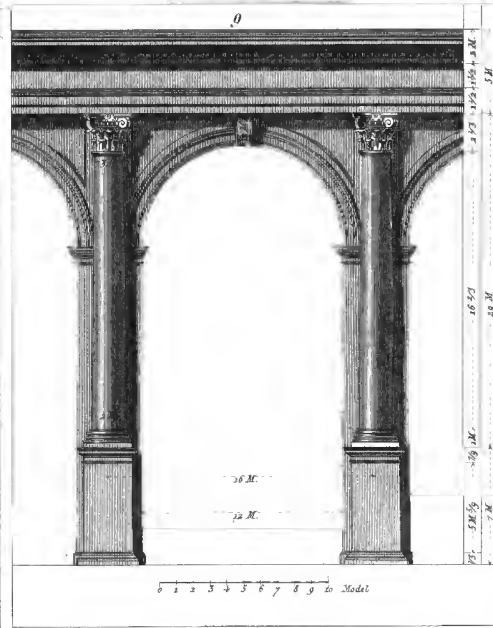
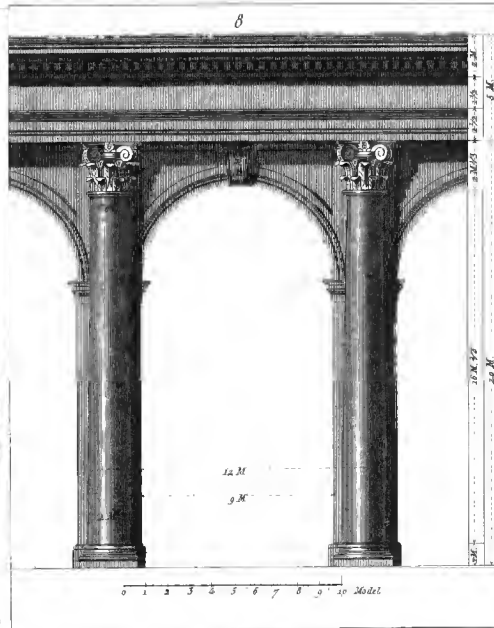
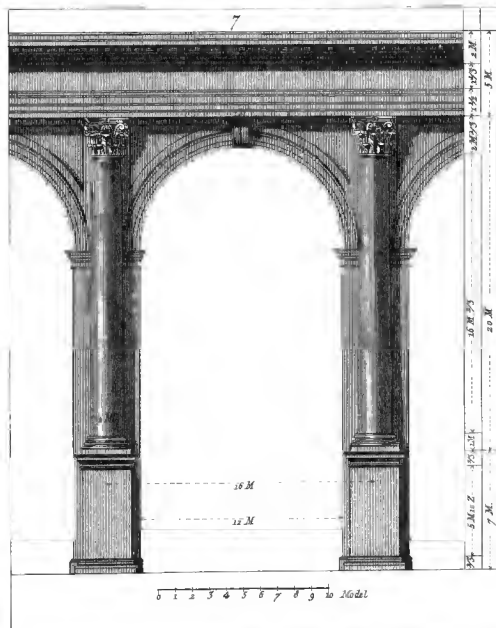
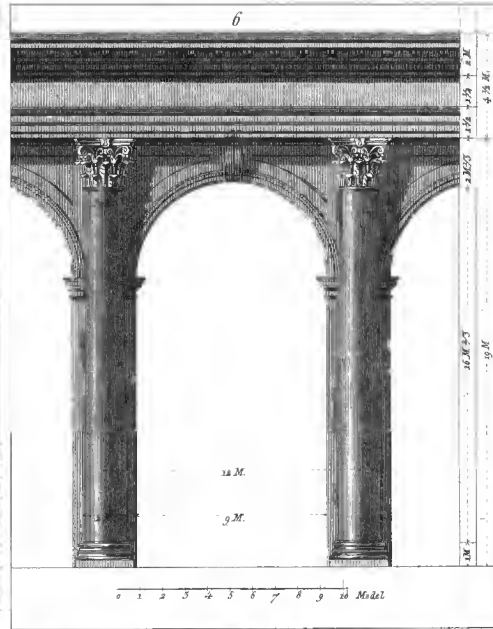
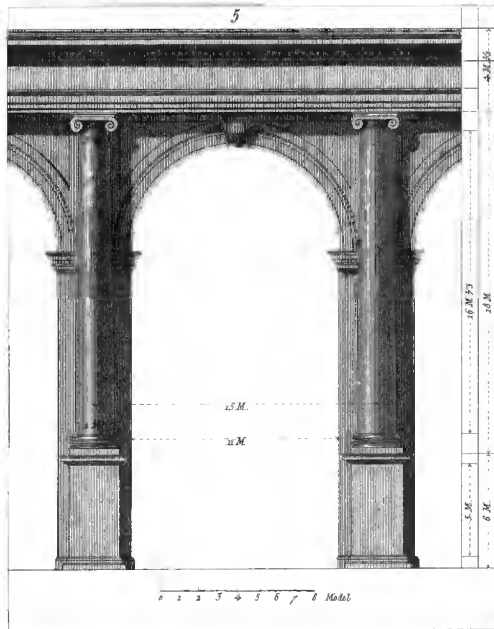
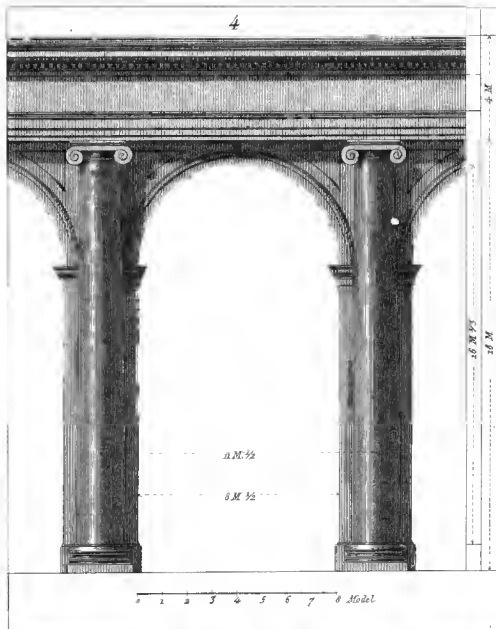
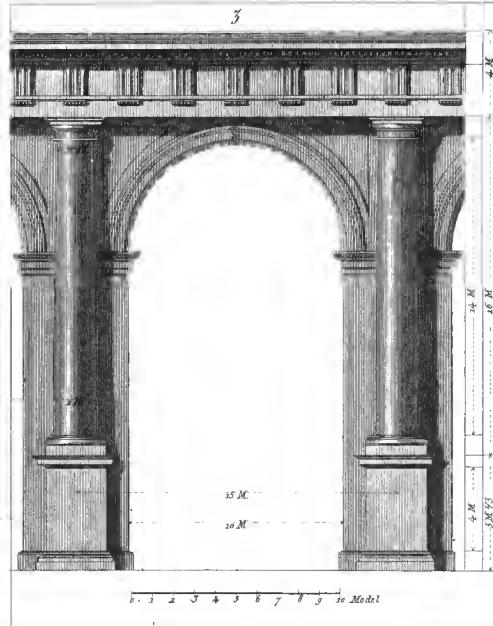
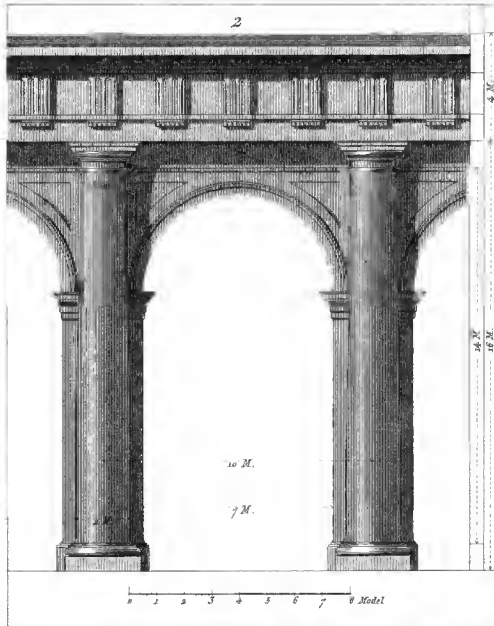
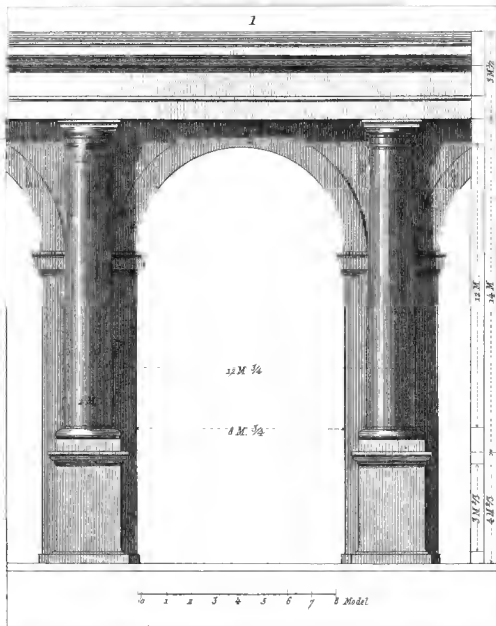


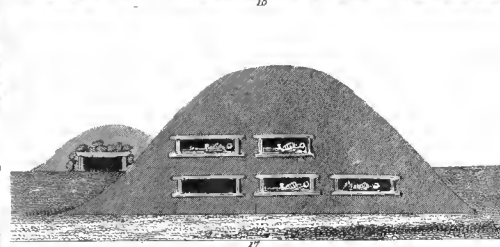
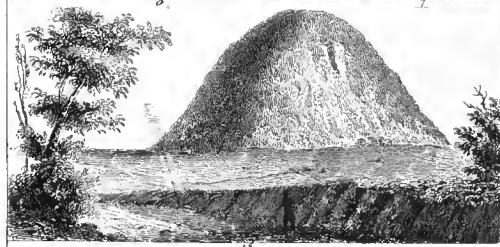
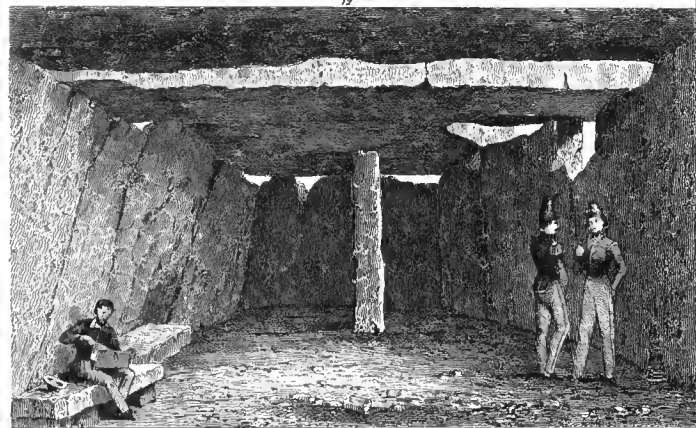
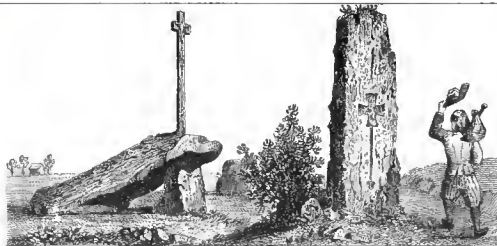
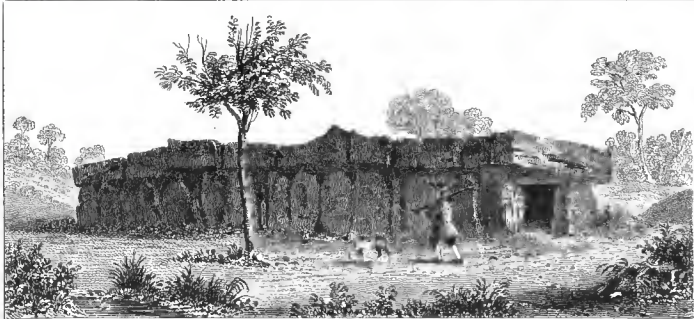


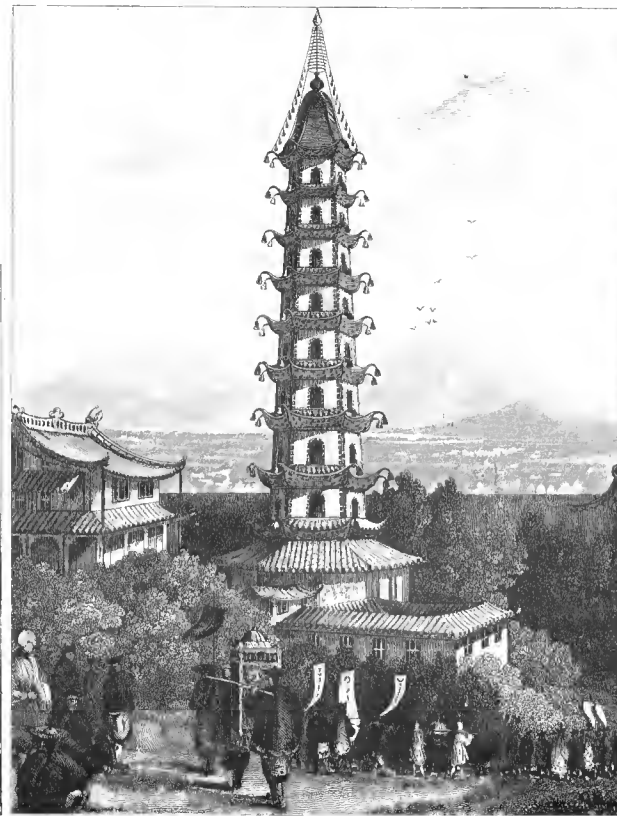
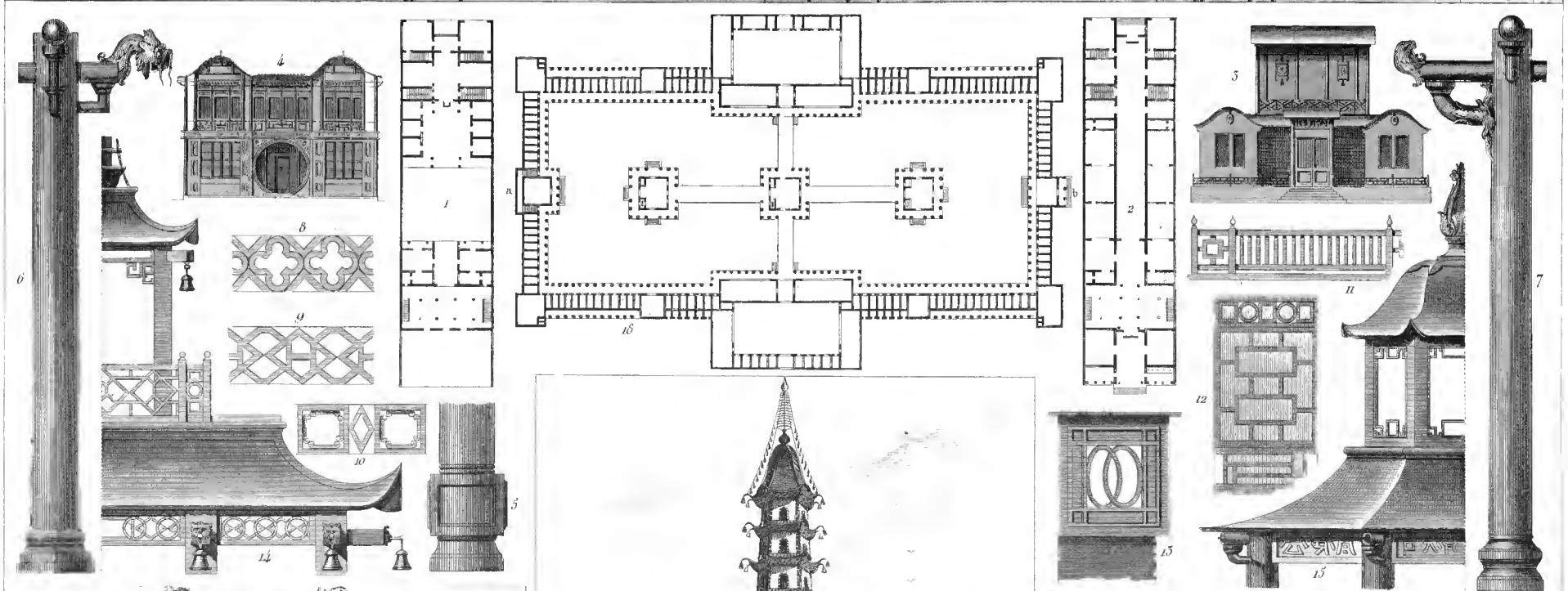


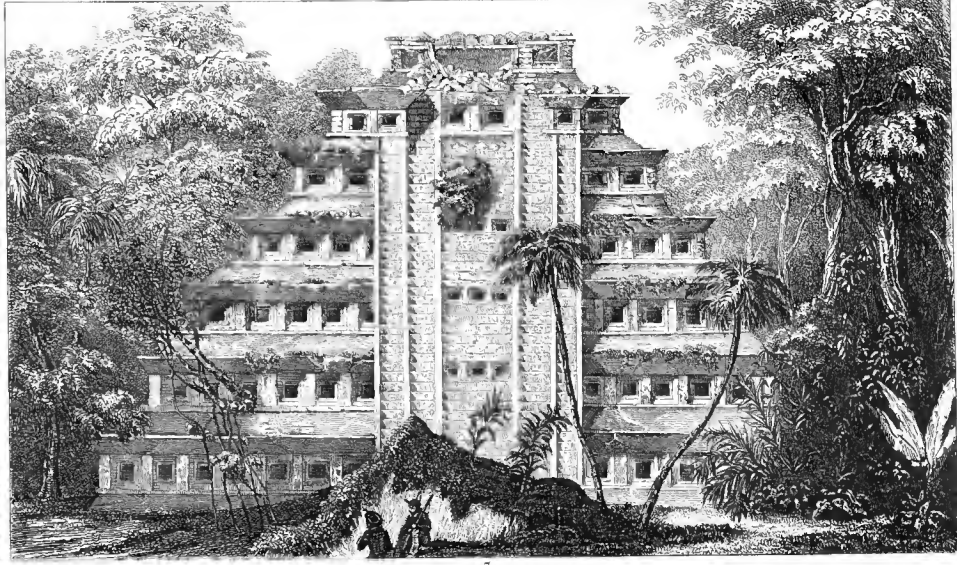
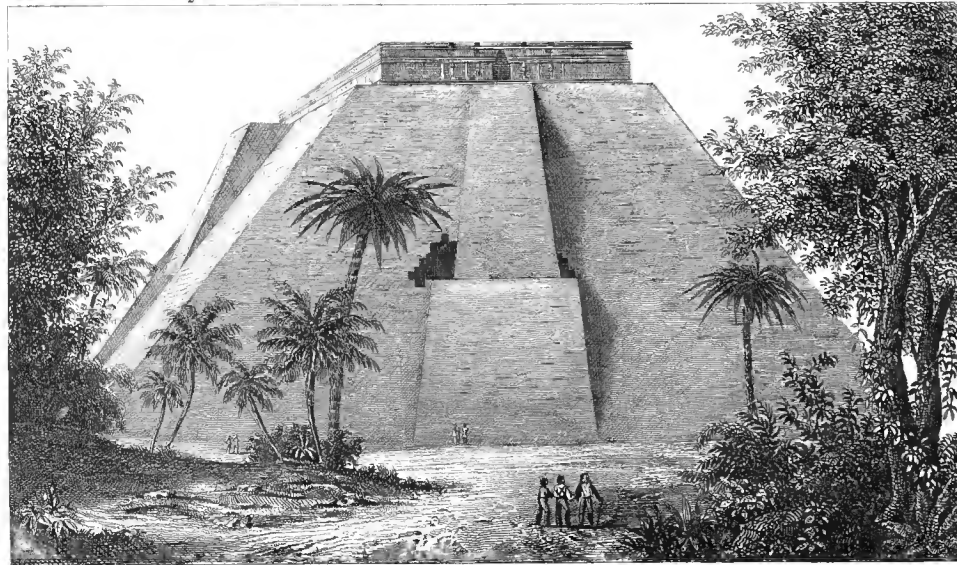
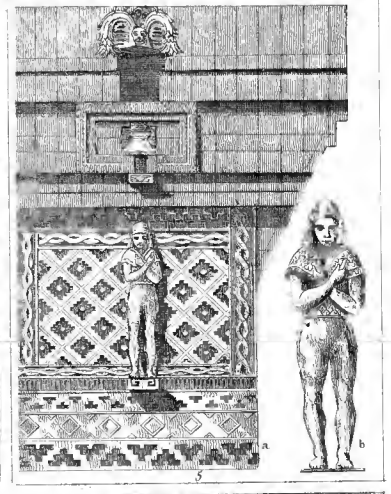
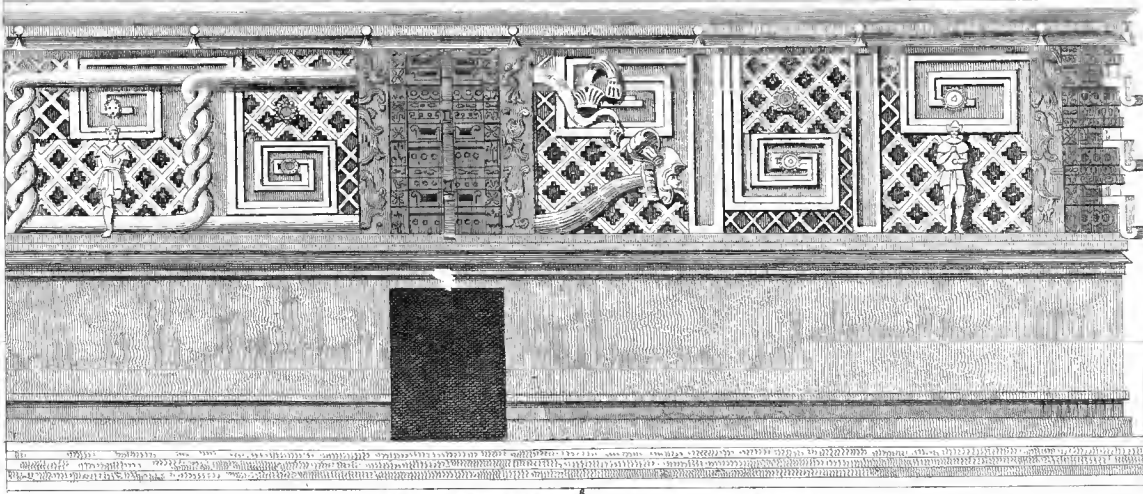
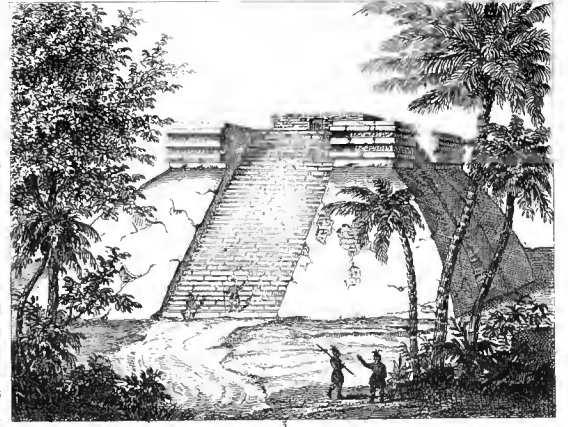
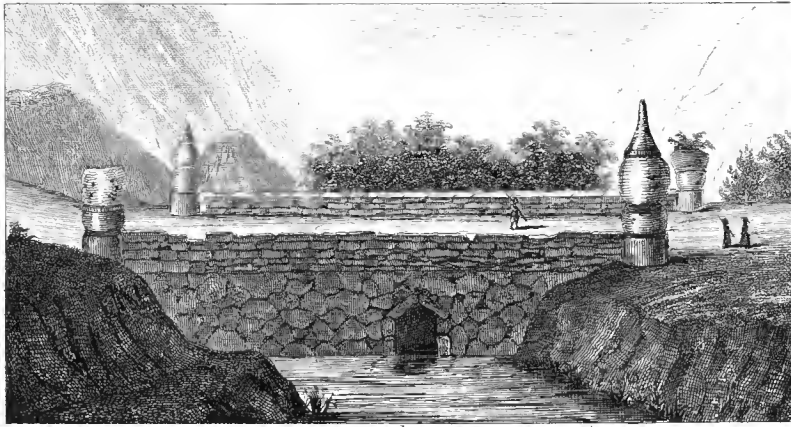


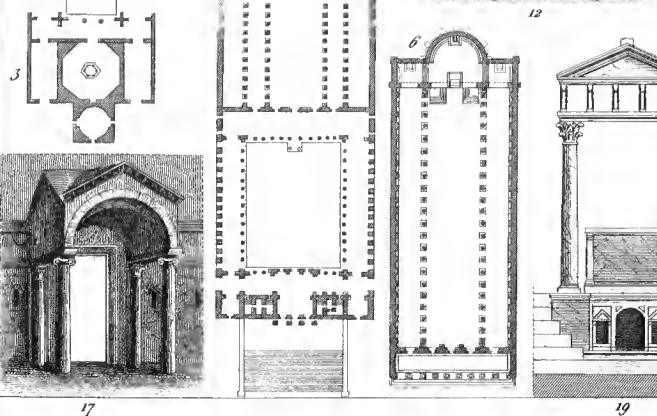
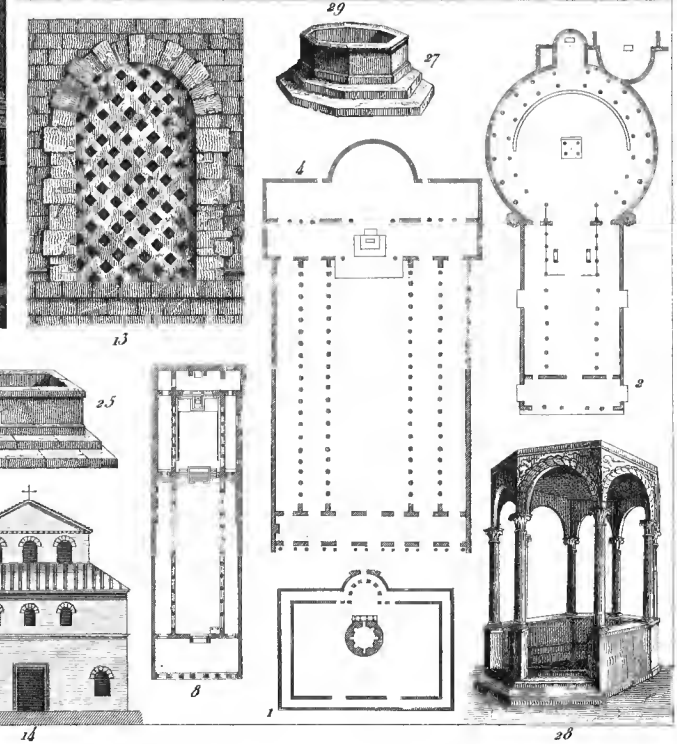
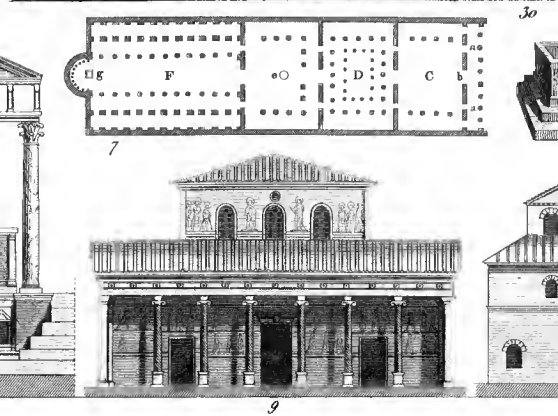
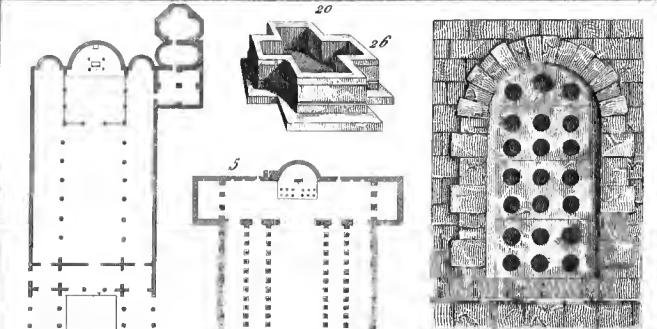
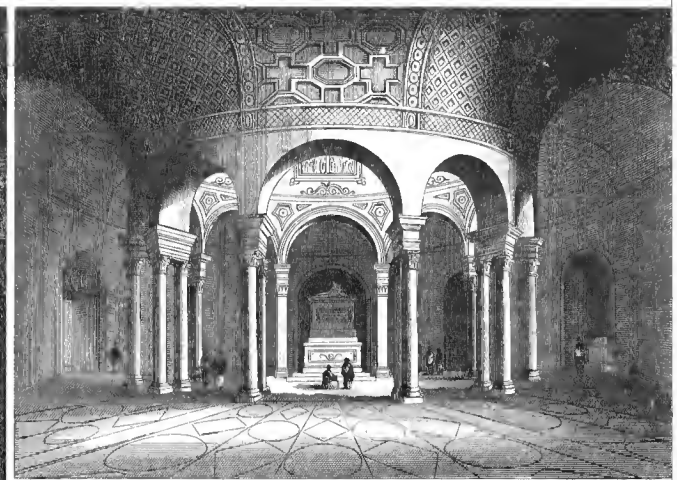
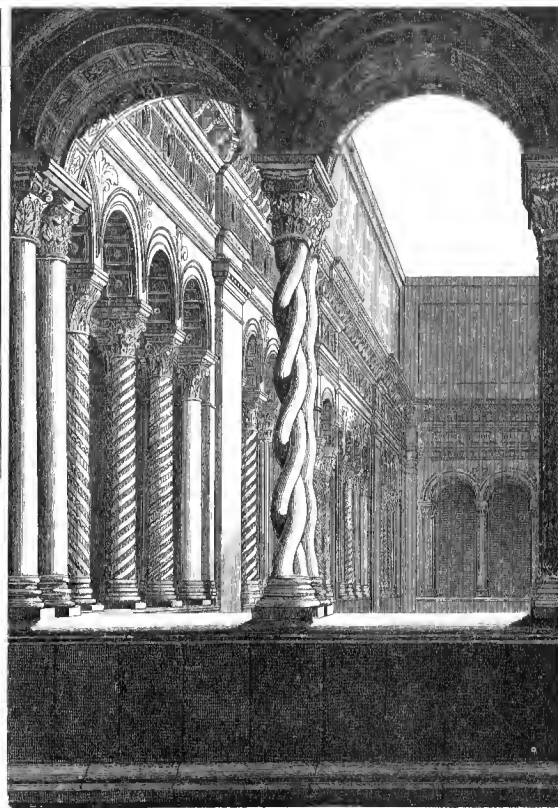
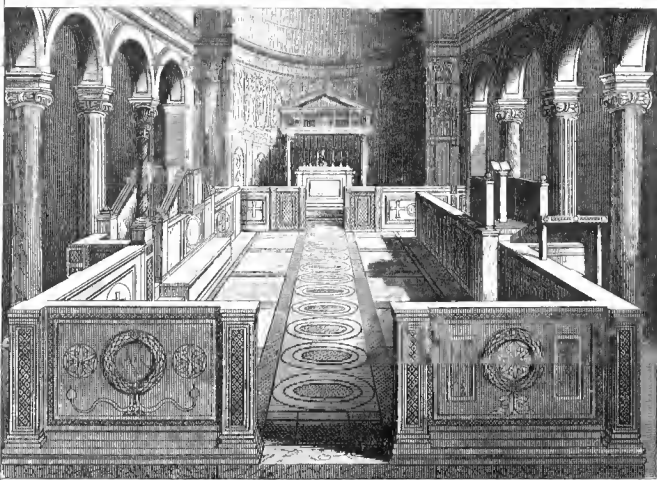
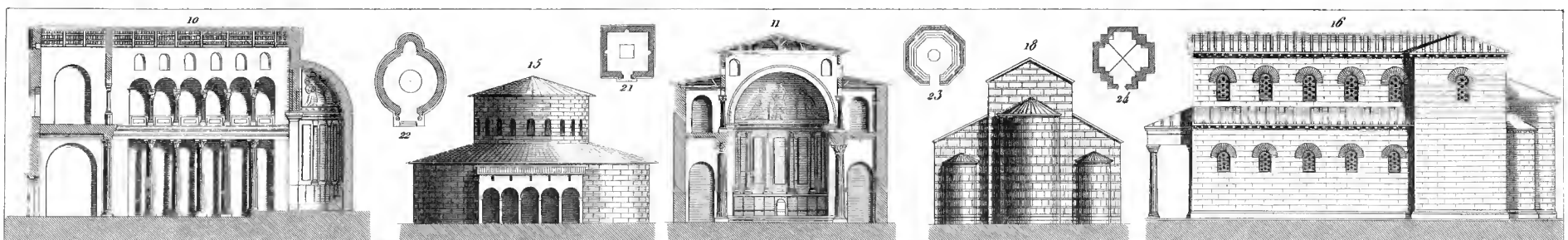


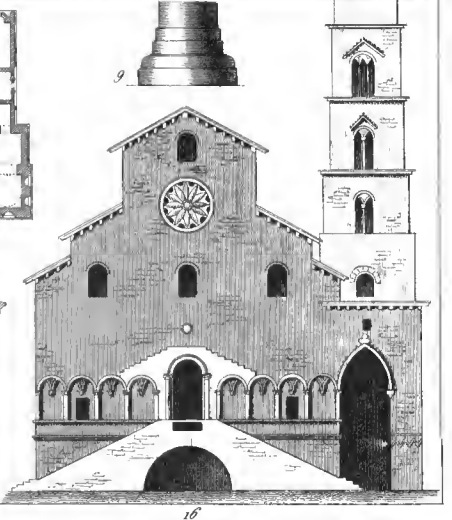
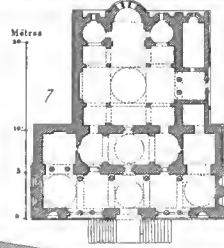
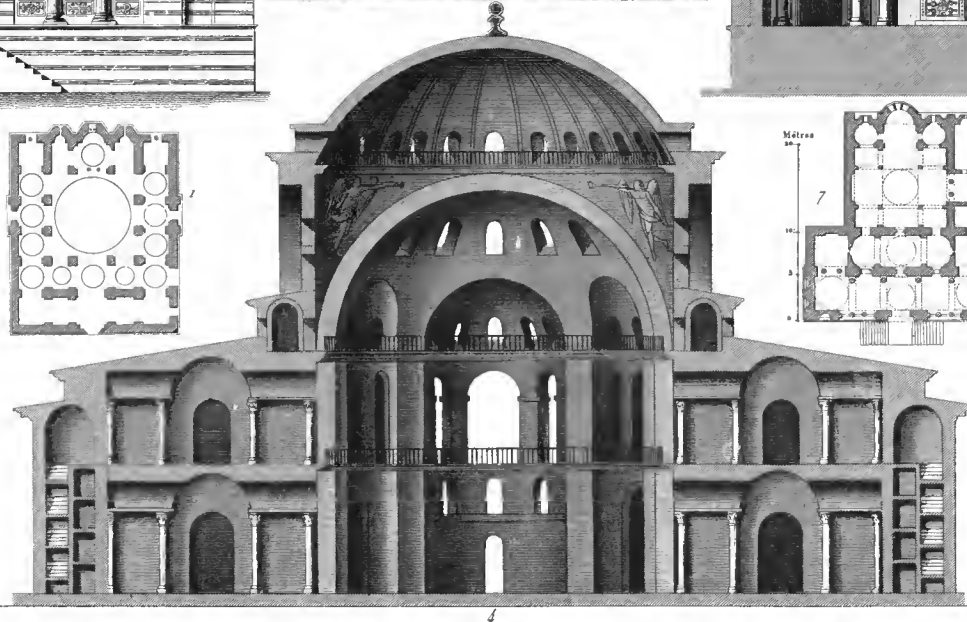
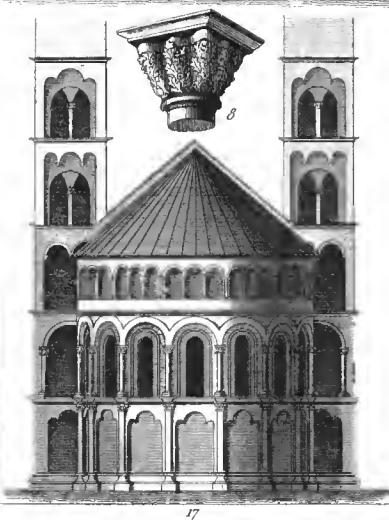
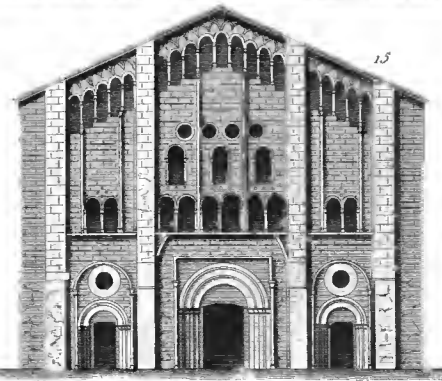
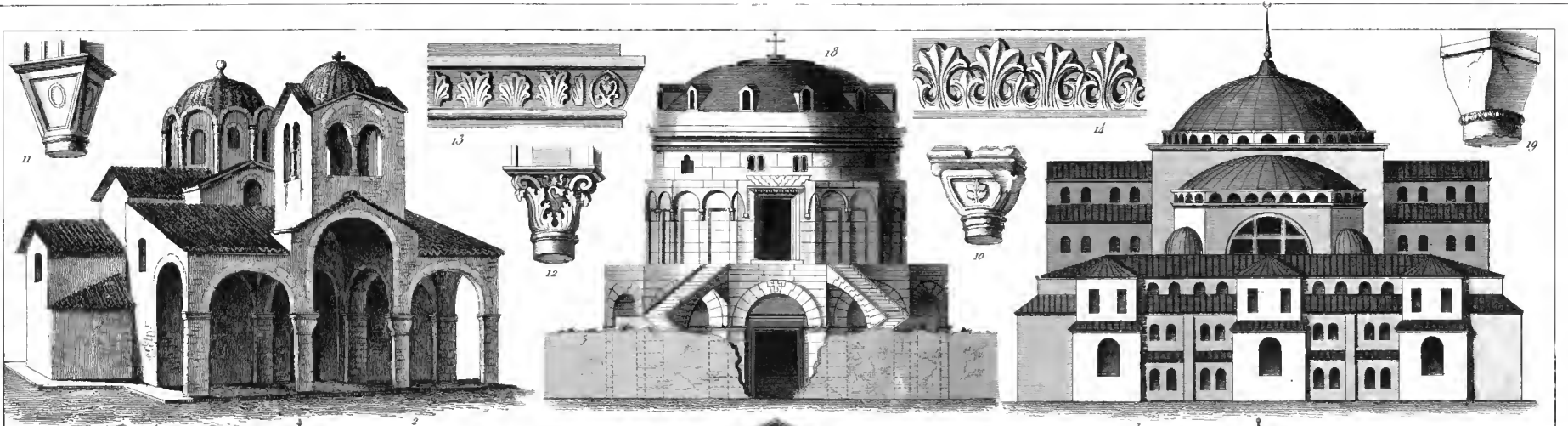


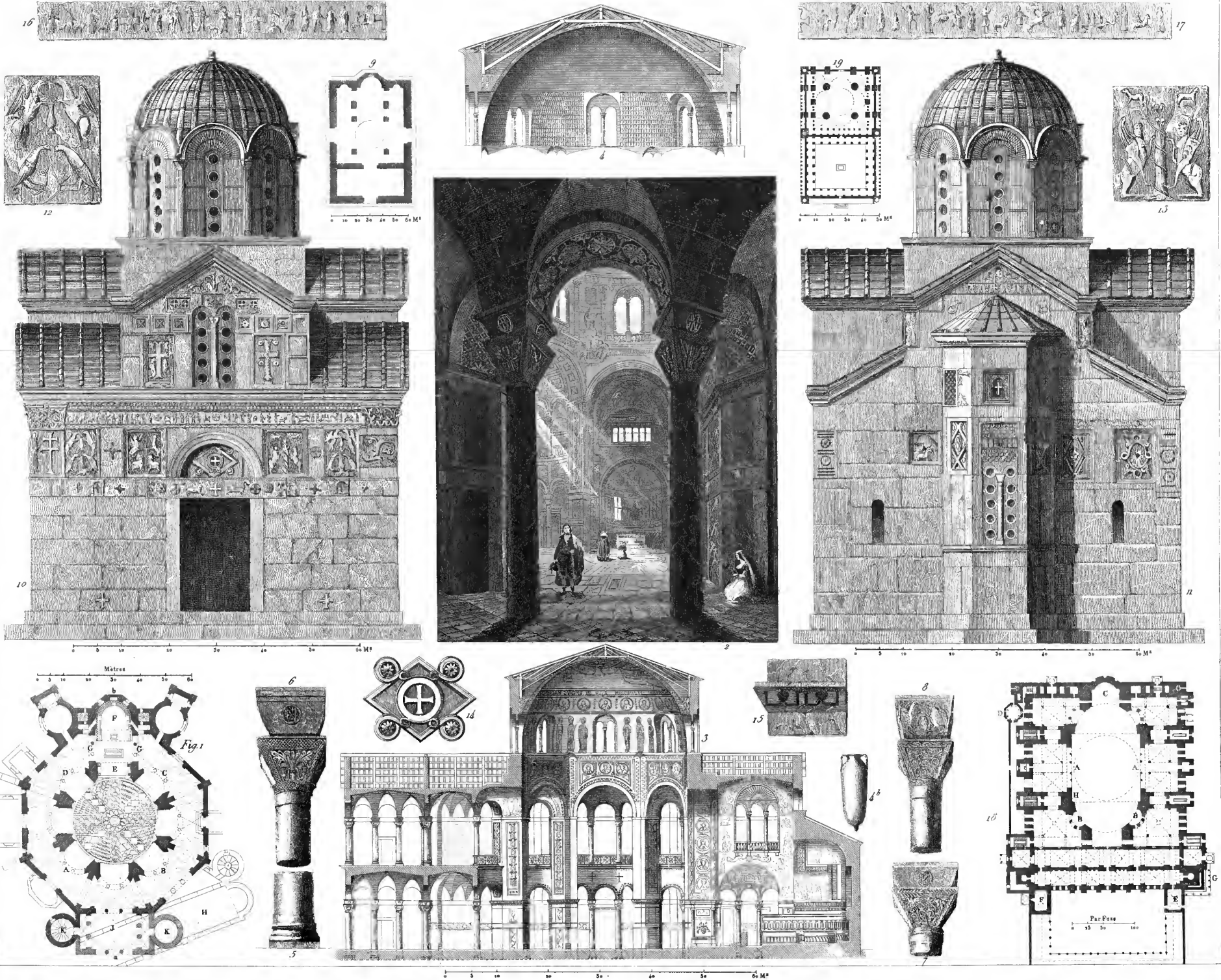


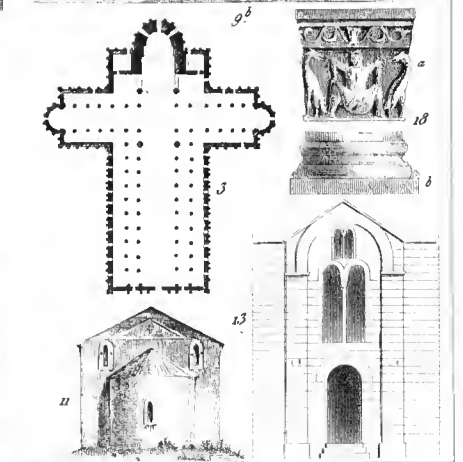
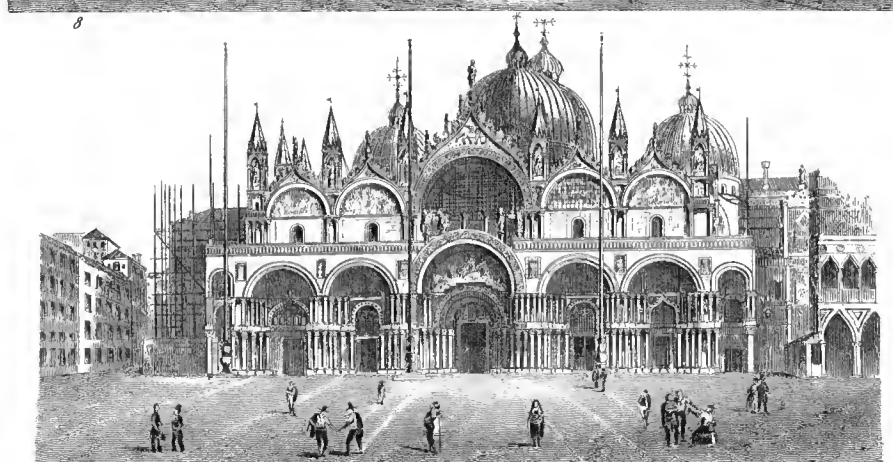
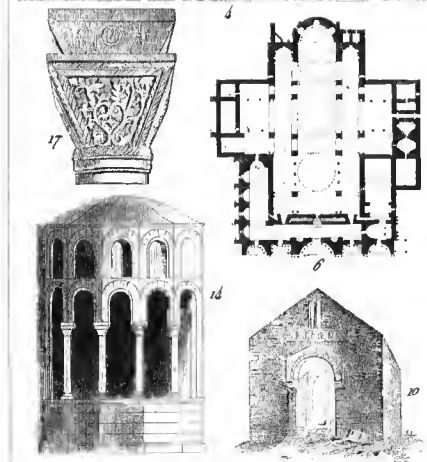
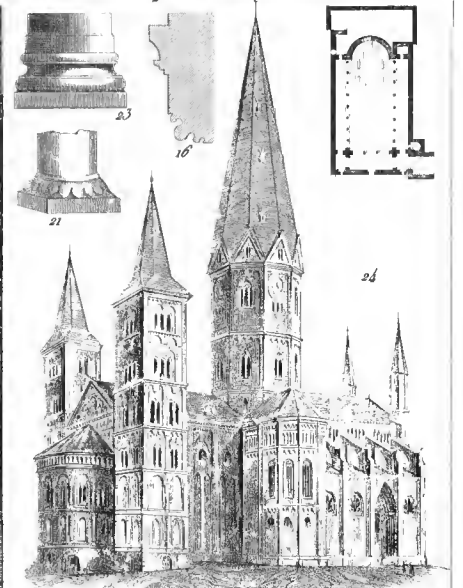
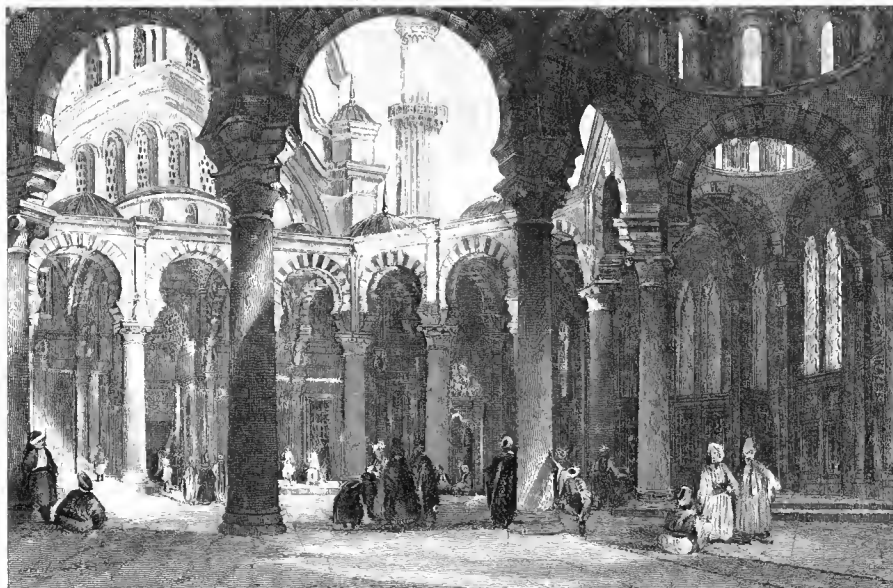
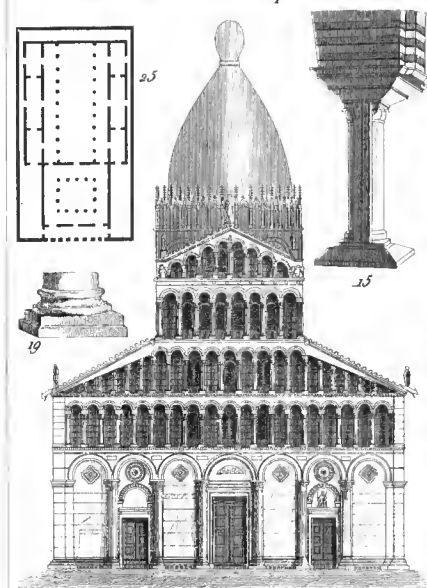
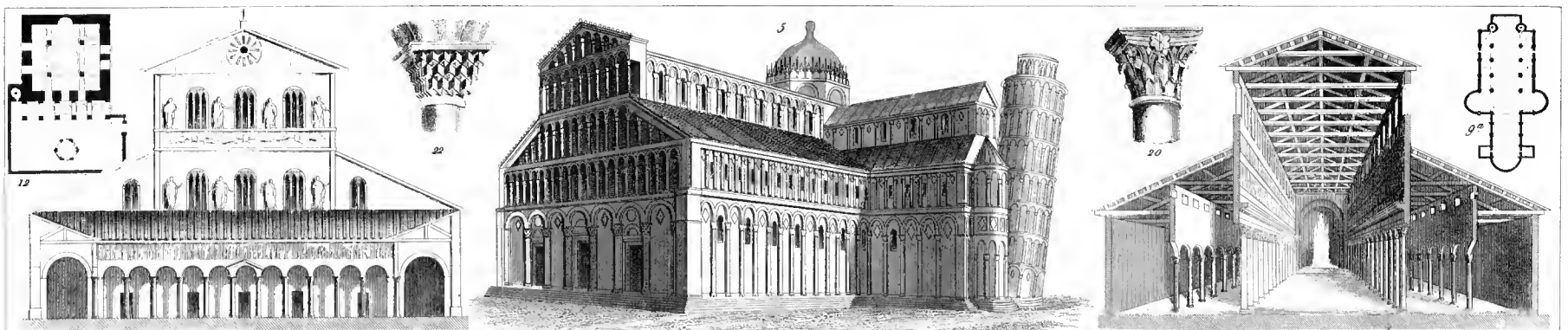


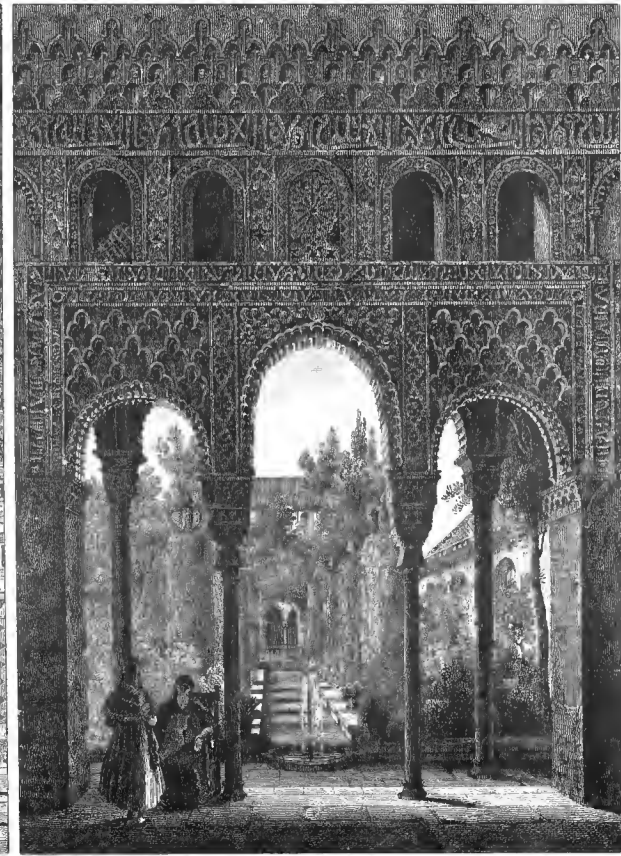
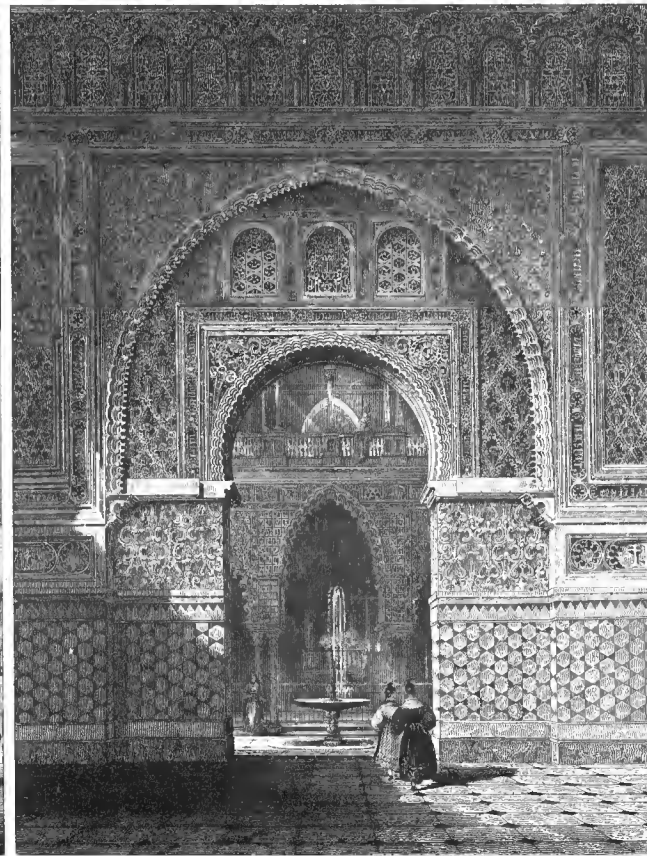
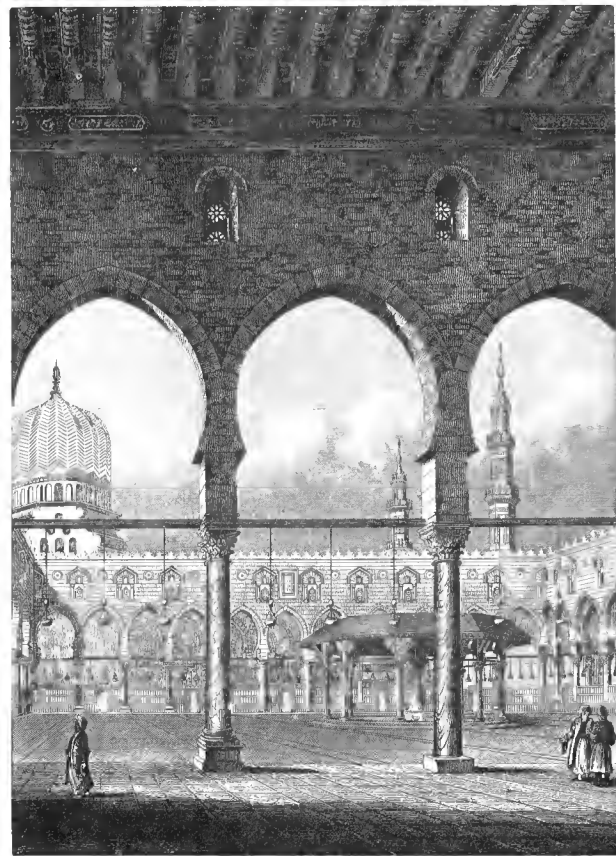
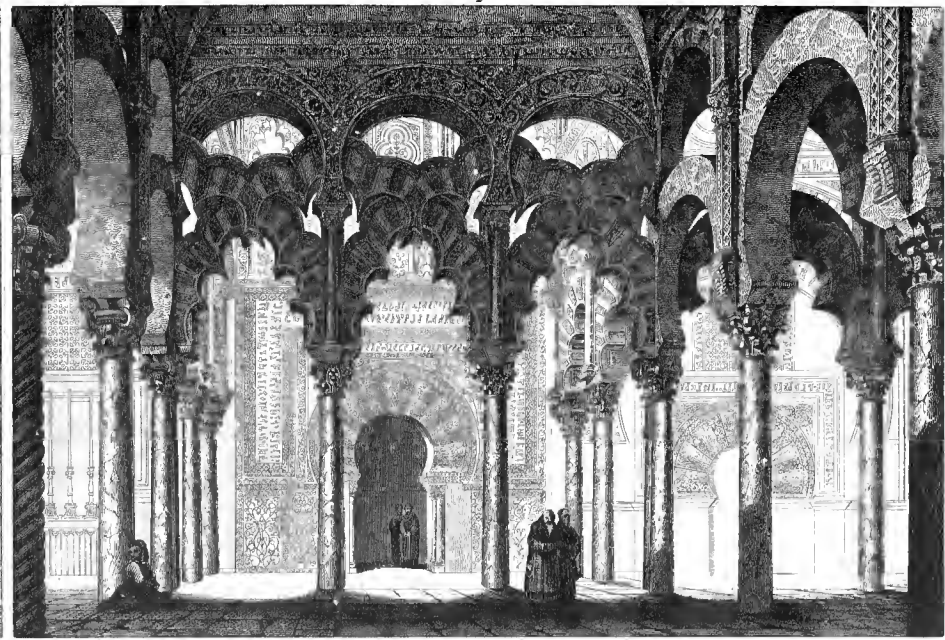








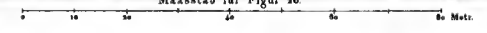
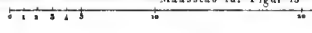
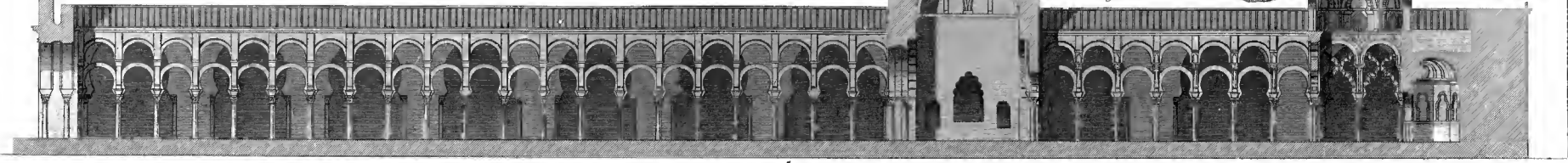
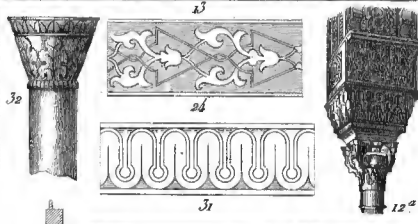
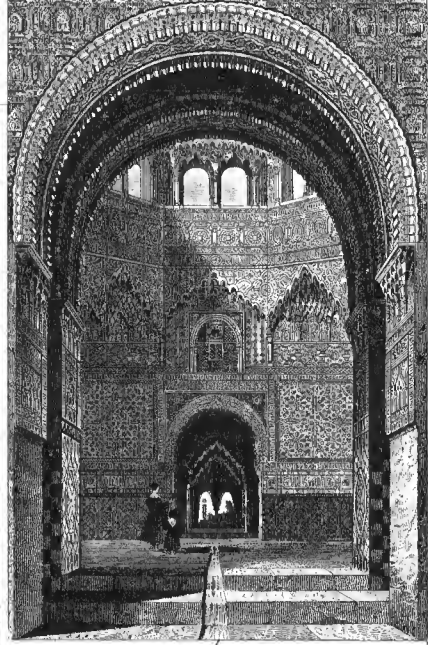
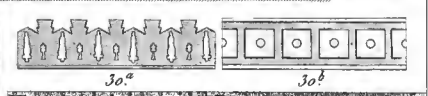
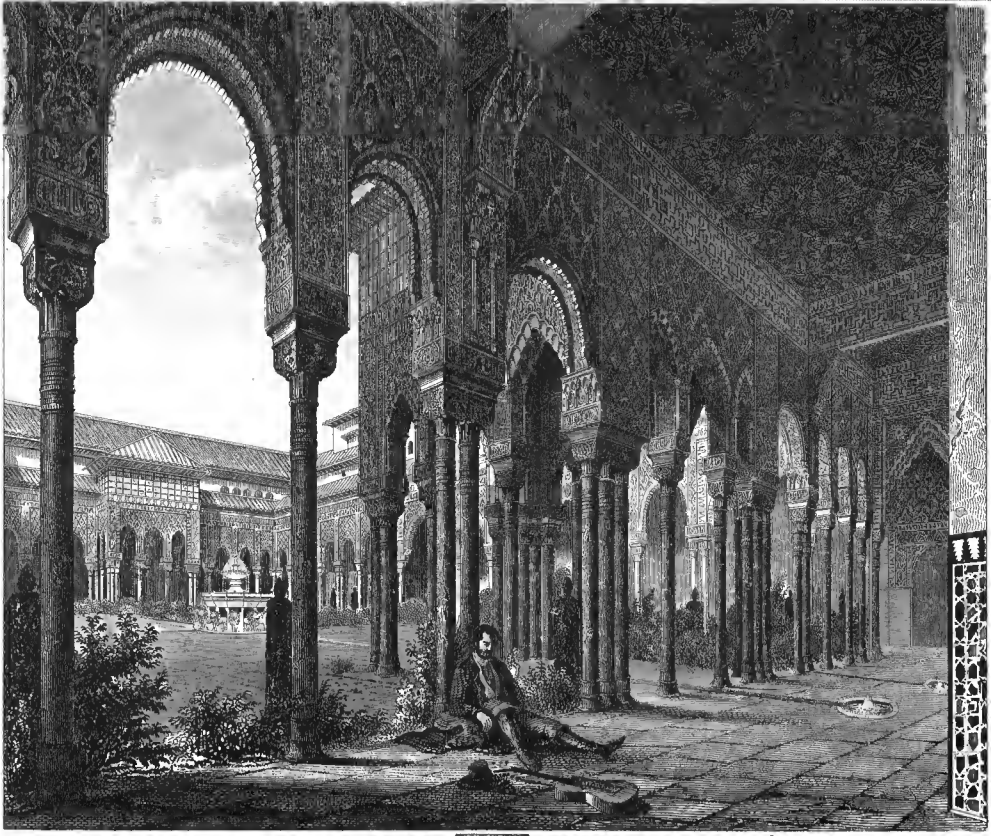
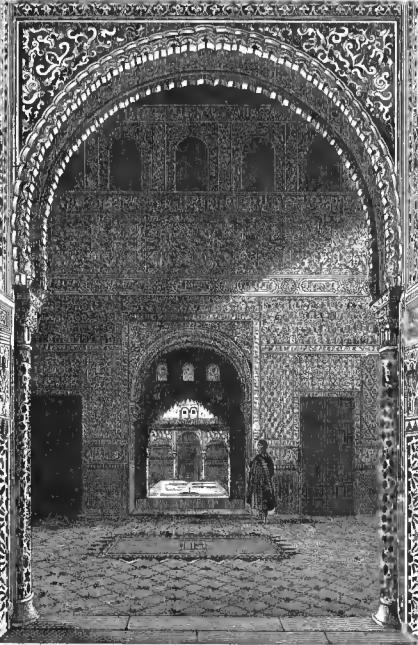
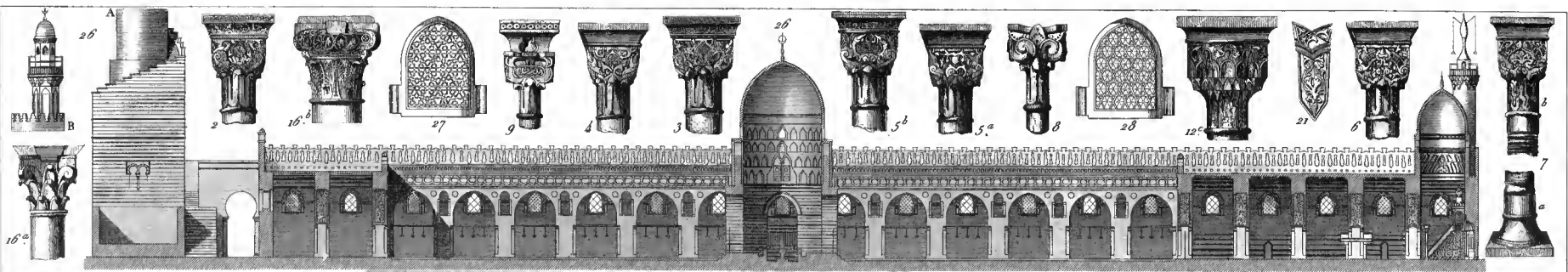


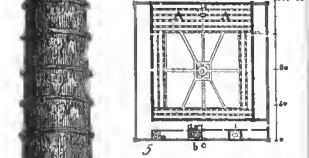
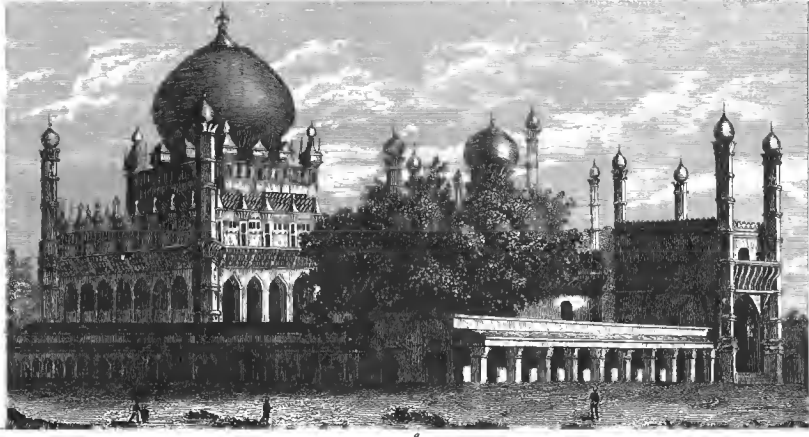
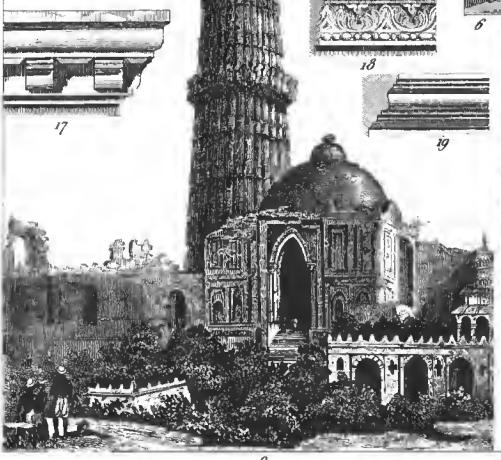
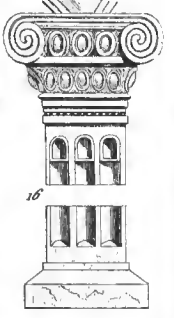
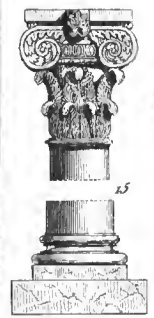
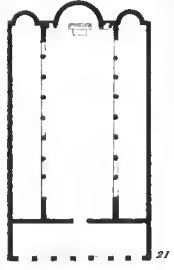
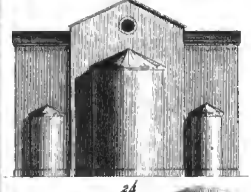
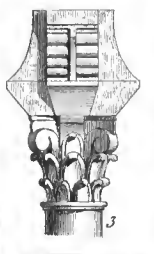
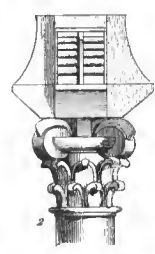
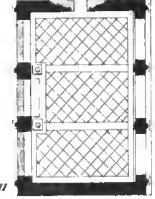
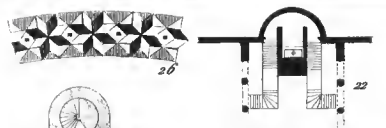
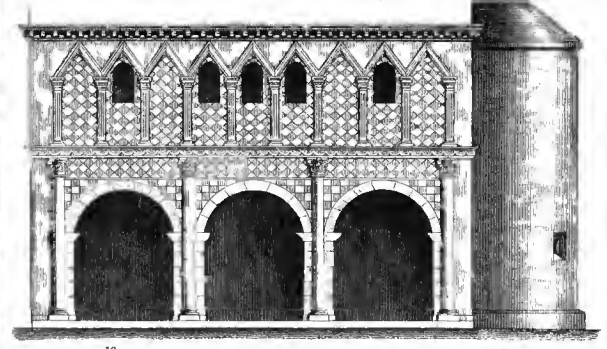
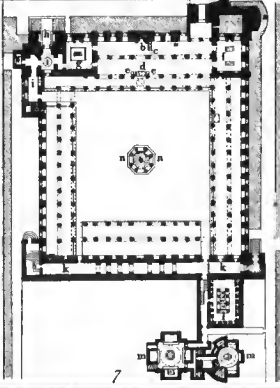
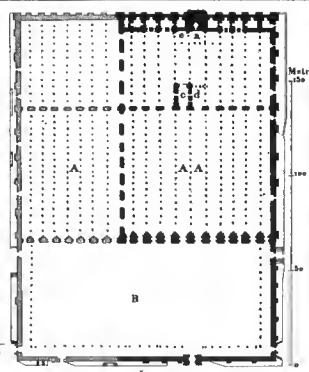
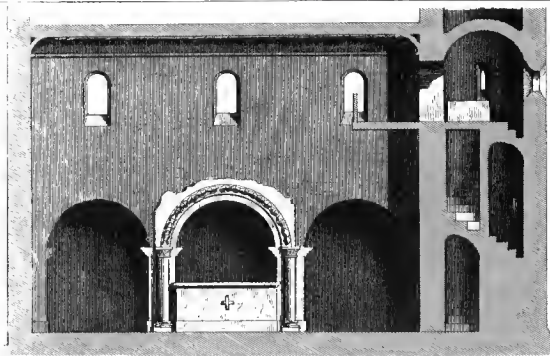


5

5

5





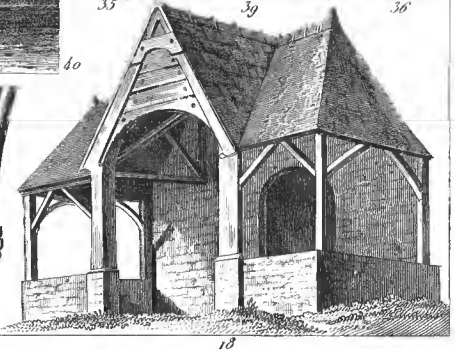
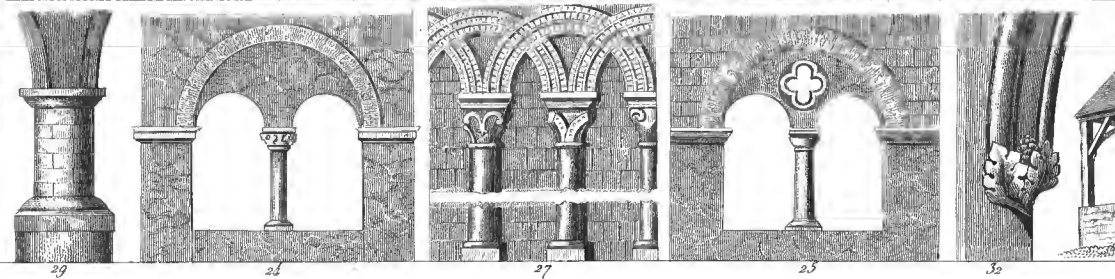
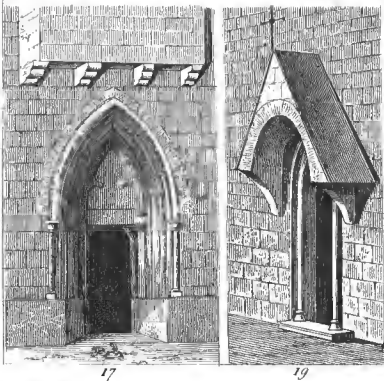
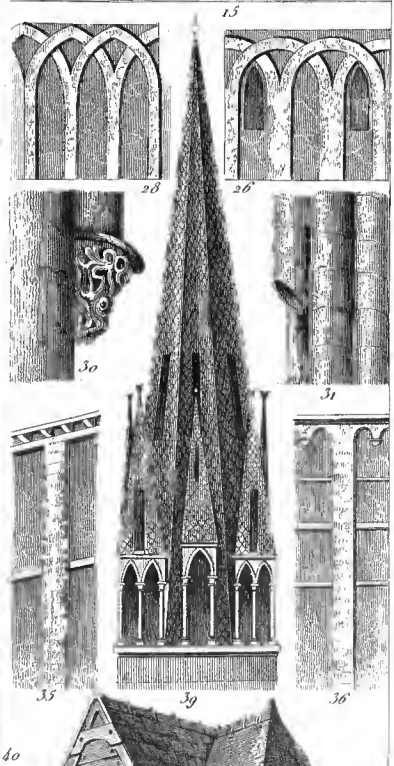
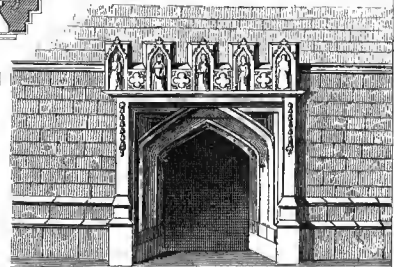
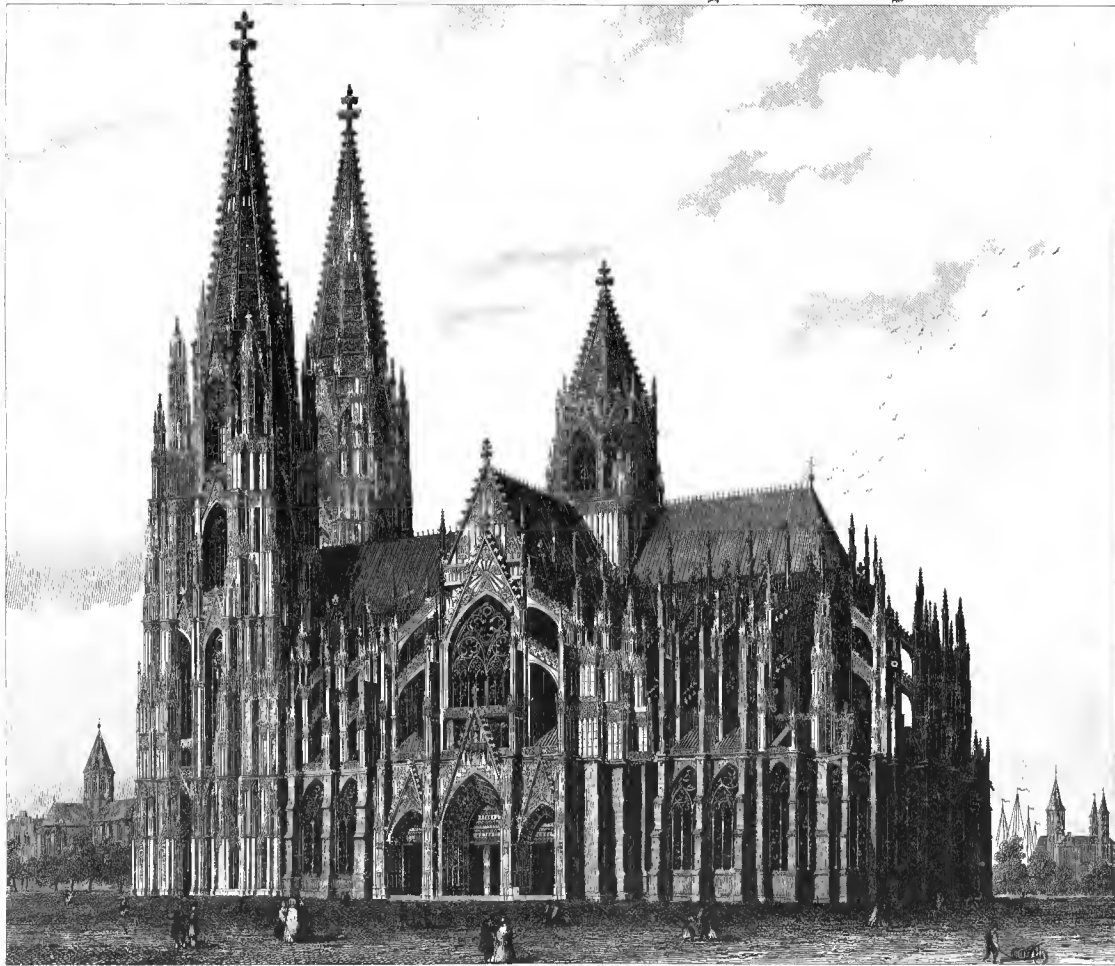
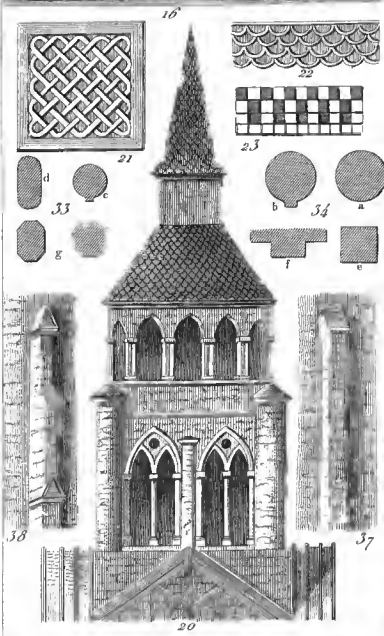
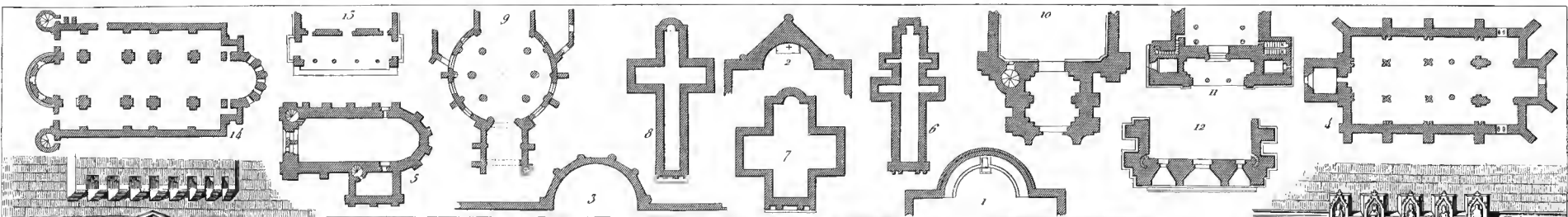
G. Heck dicit

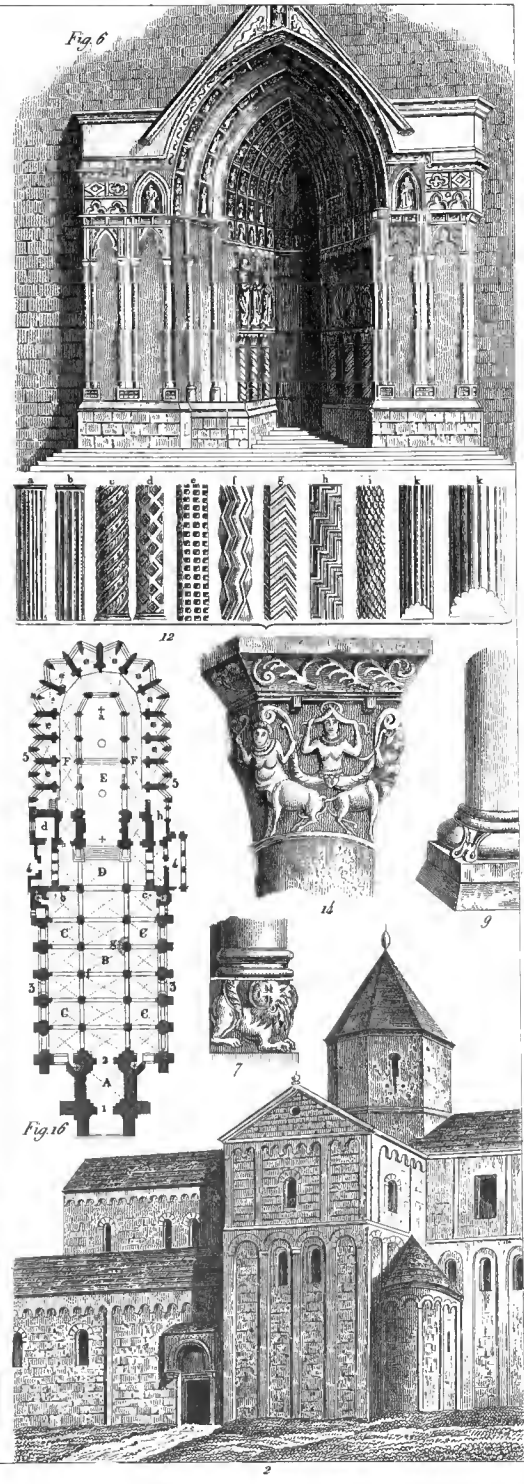
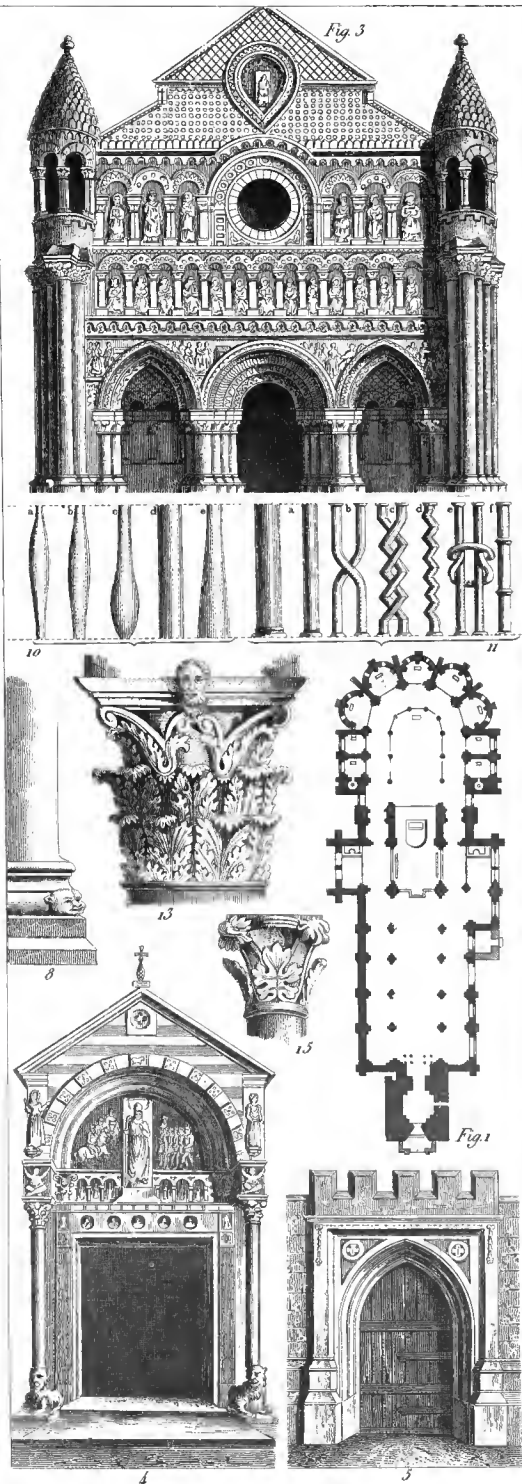
Maasstab für Fig. 13.

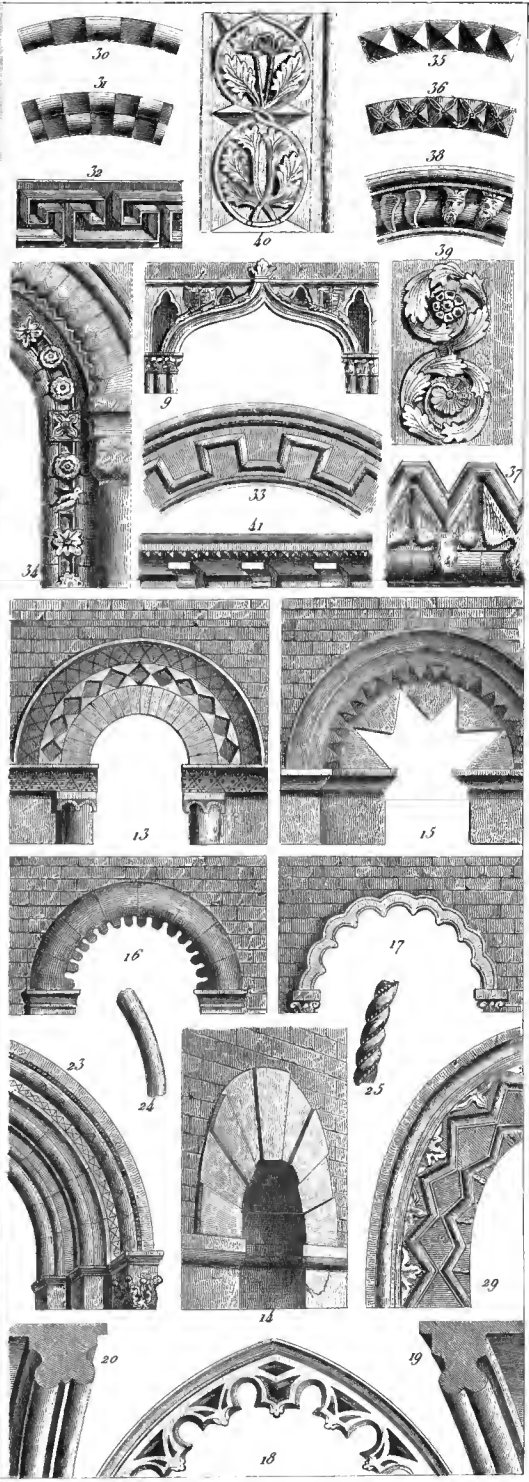
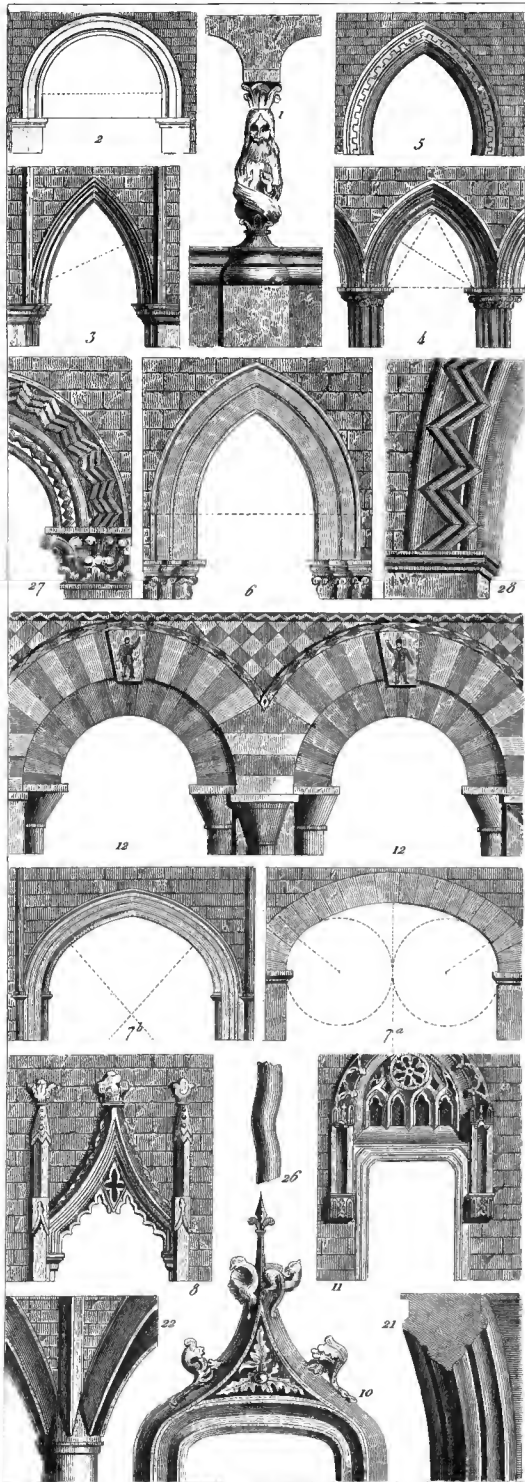
Maasstab für Fig. 11.

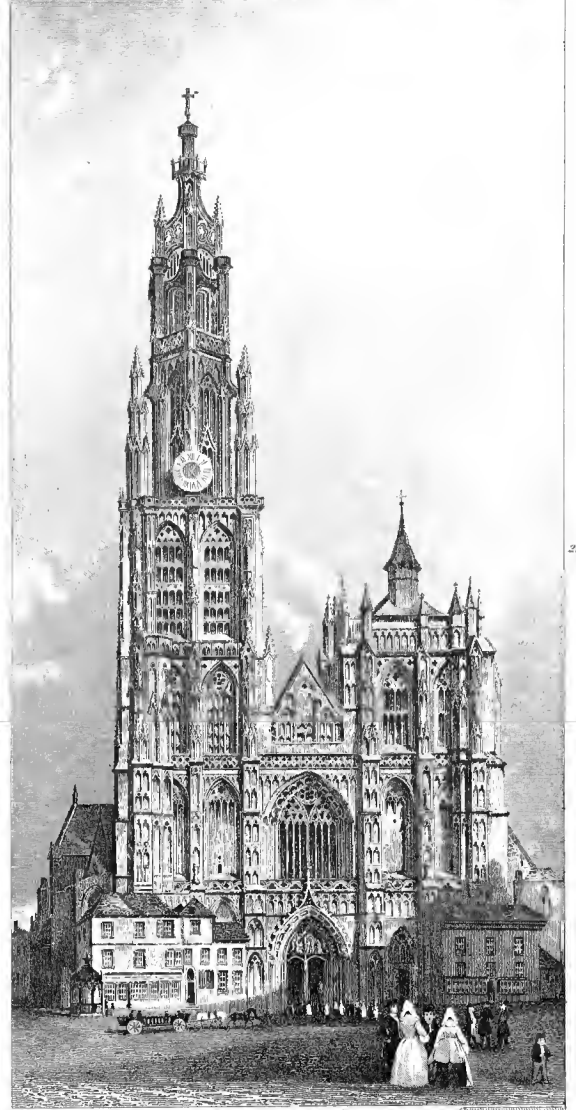
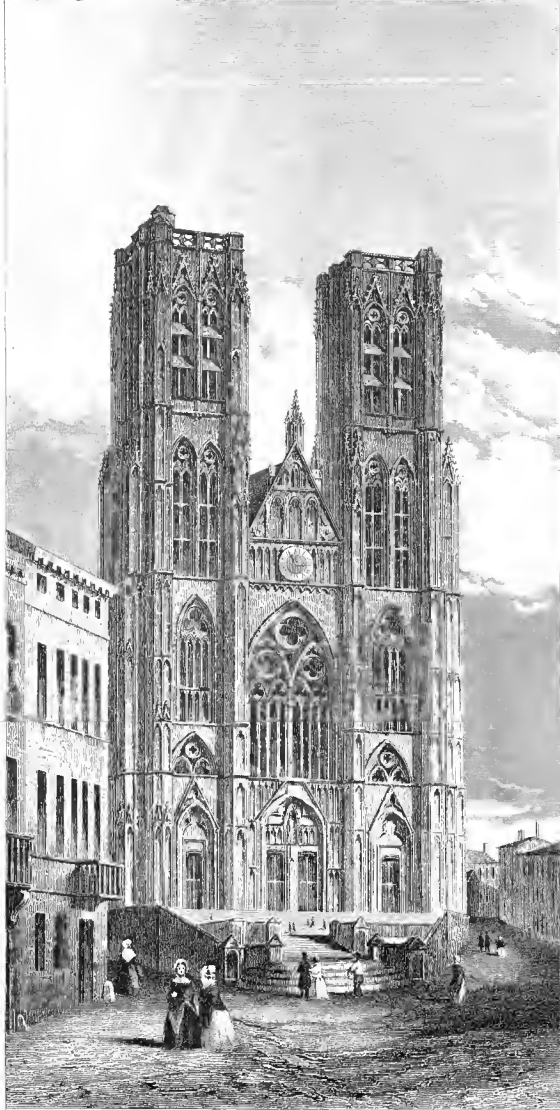
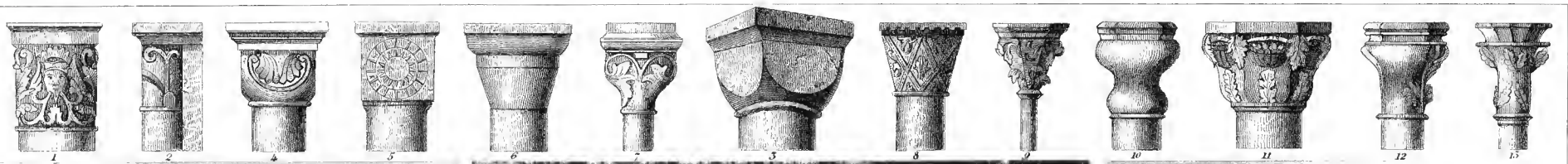
Maasstab für Fig. 15 17 19.

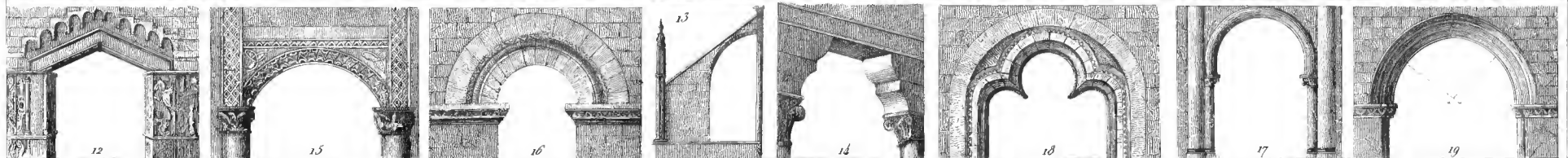
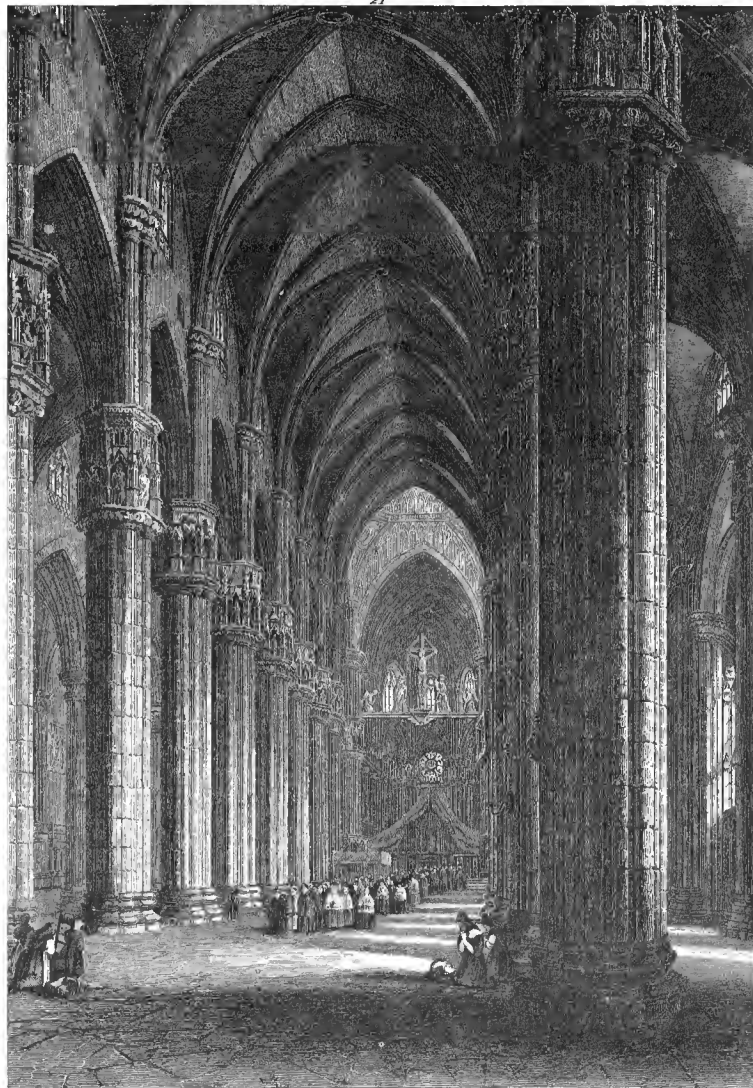
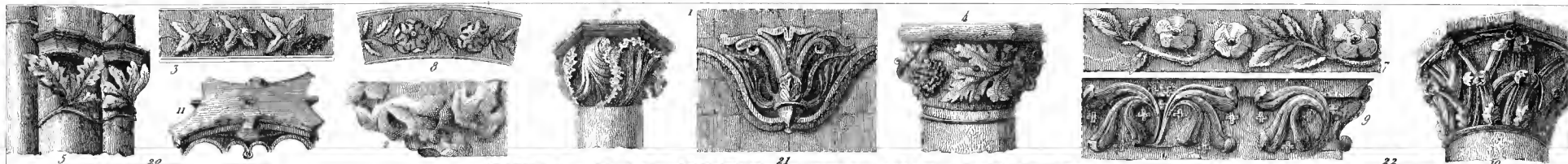
G. Kaldenberg sculp

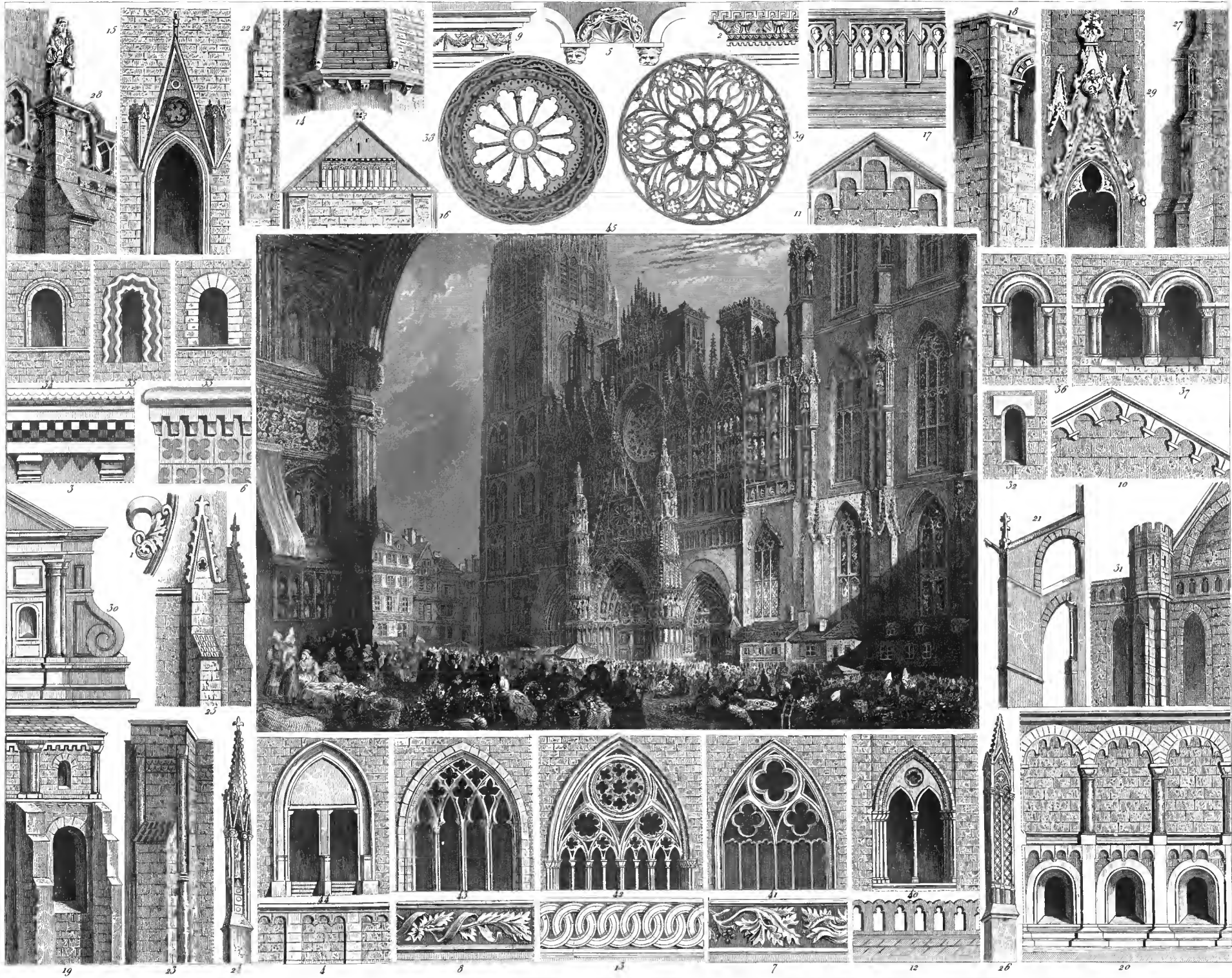


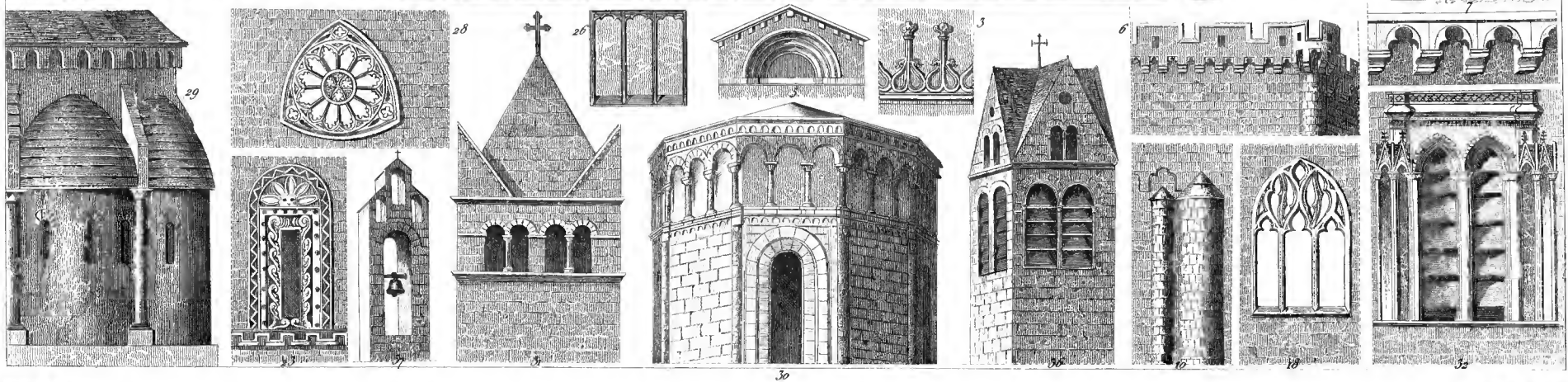
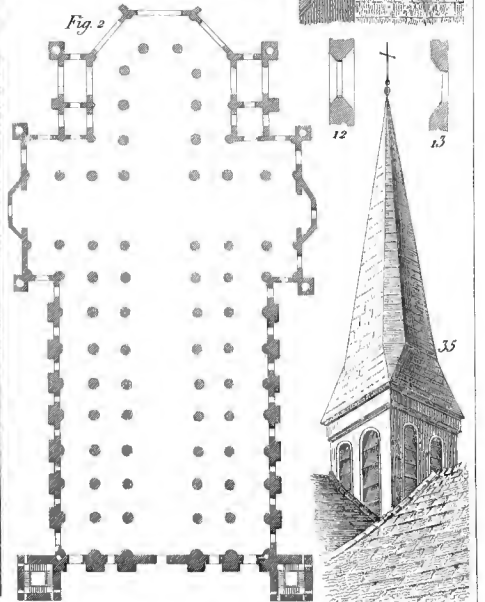
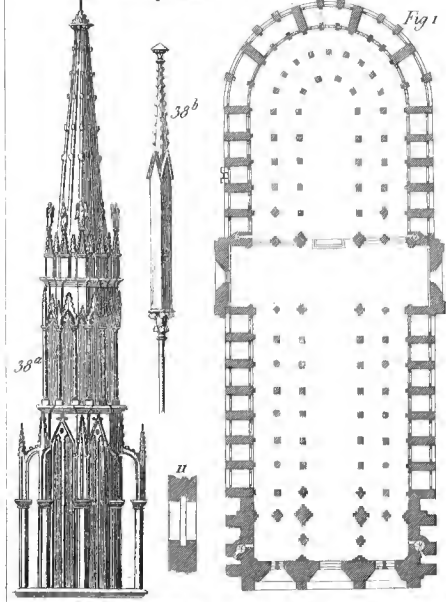
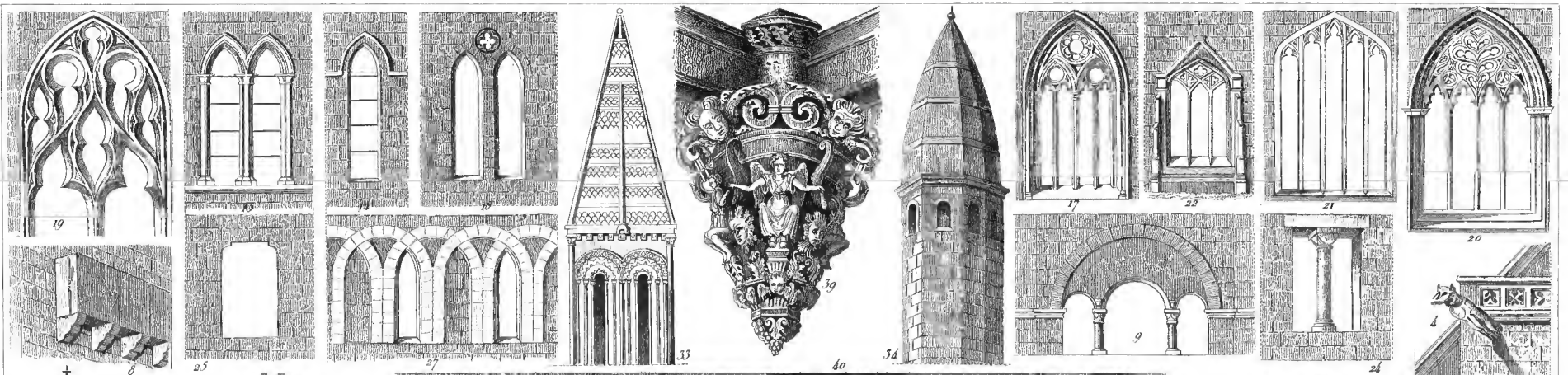


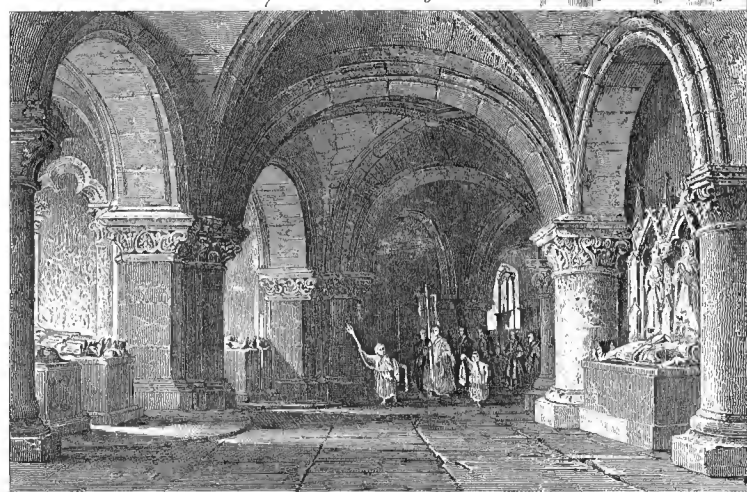
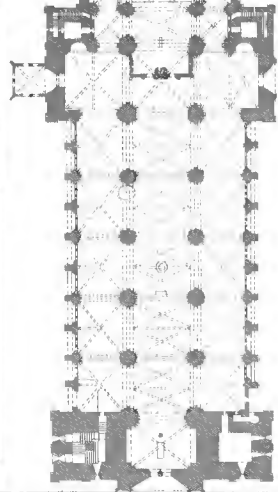
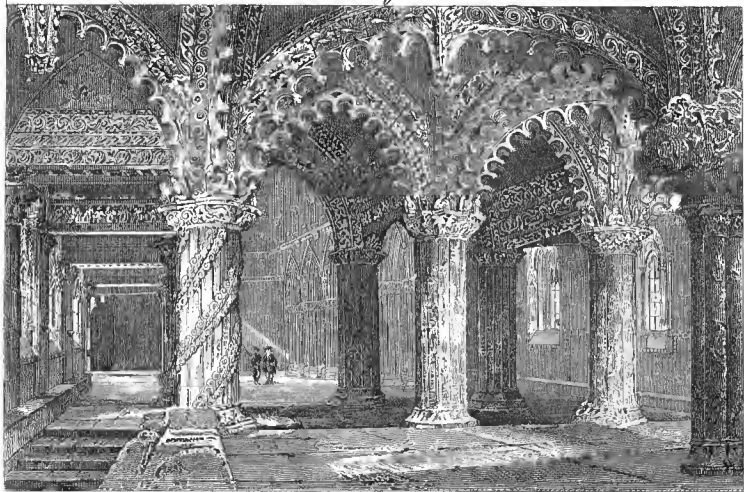
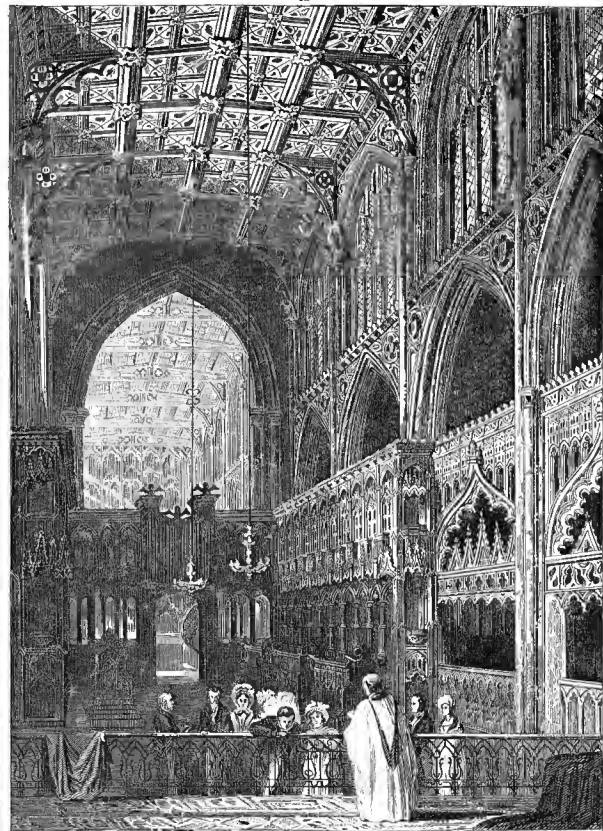


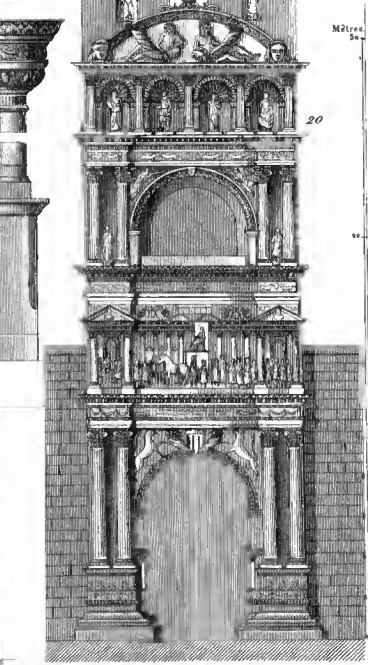
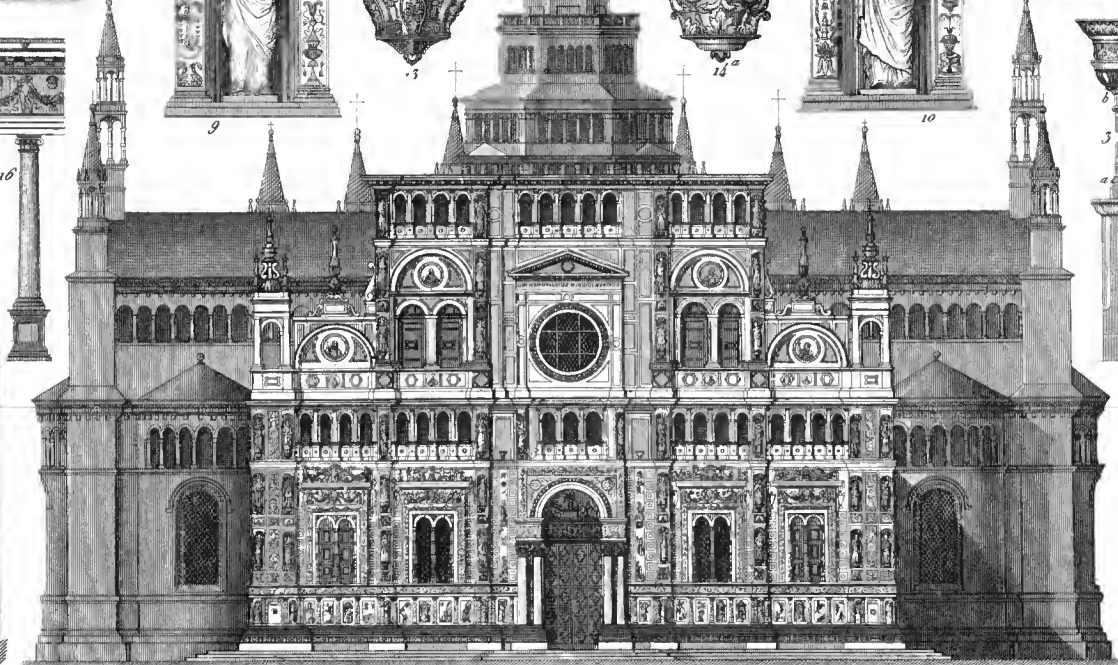
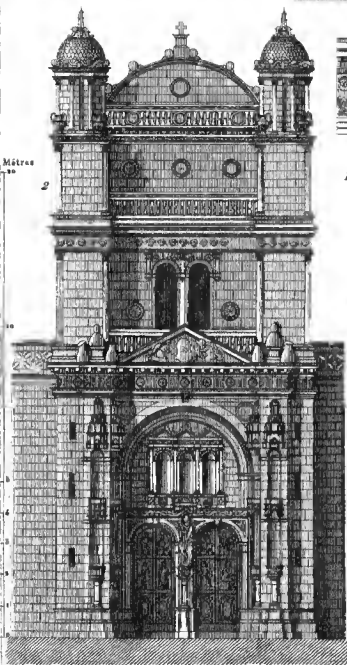
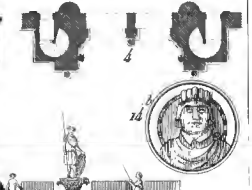
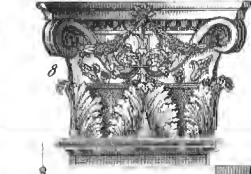
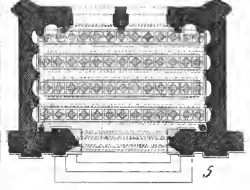
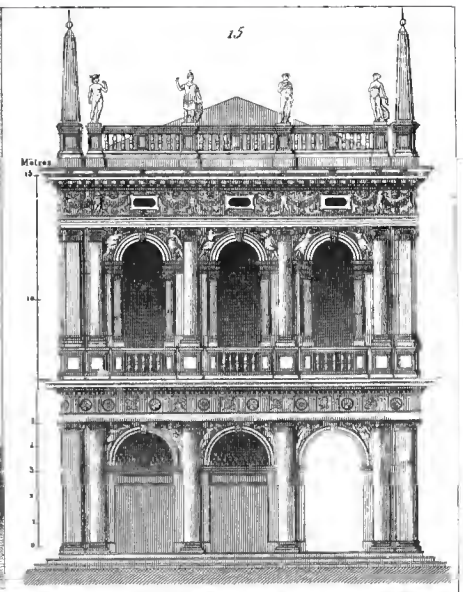
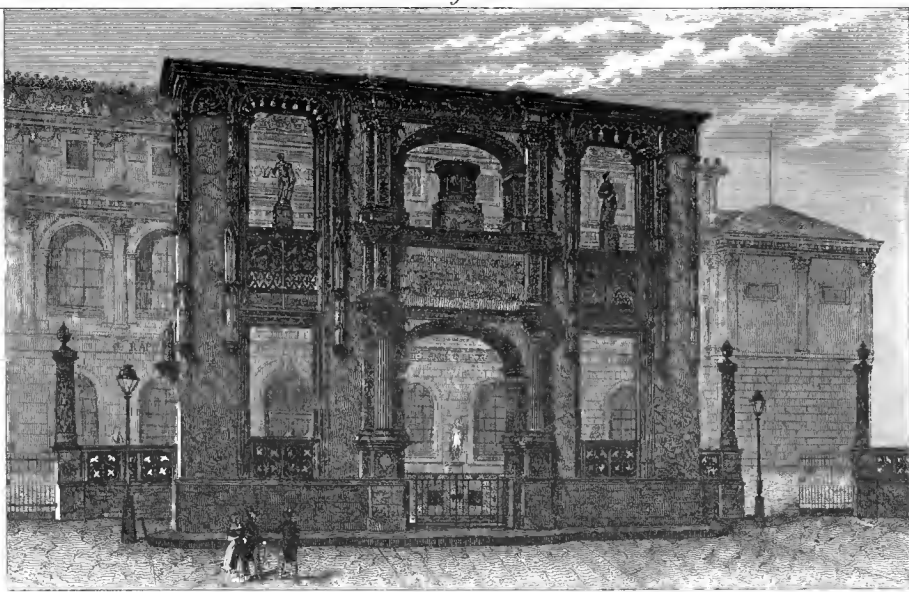
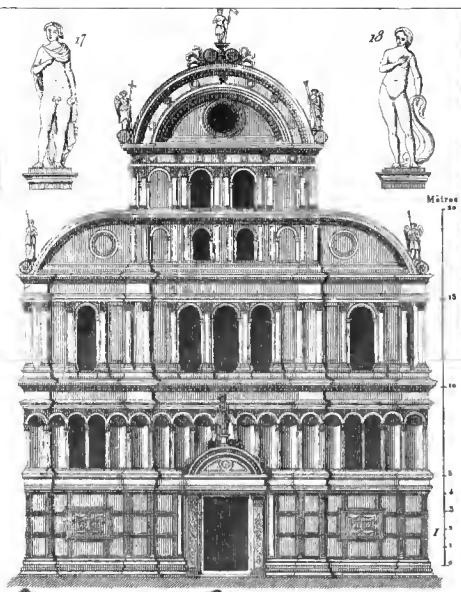




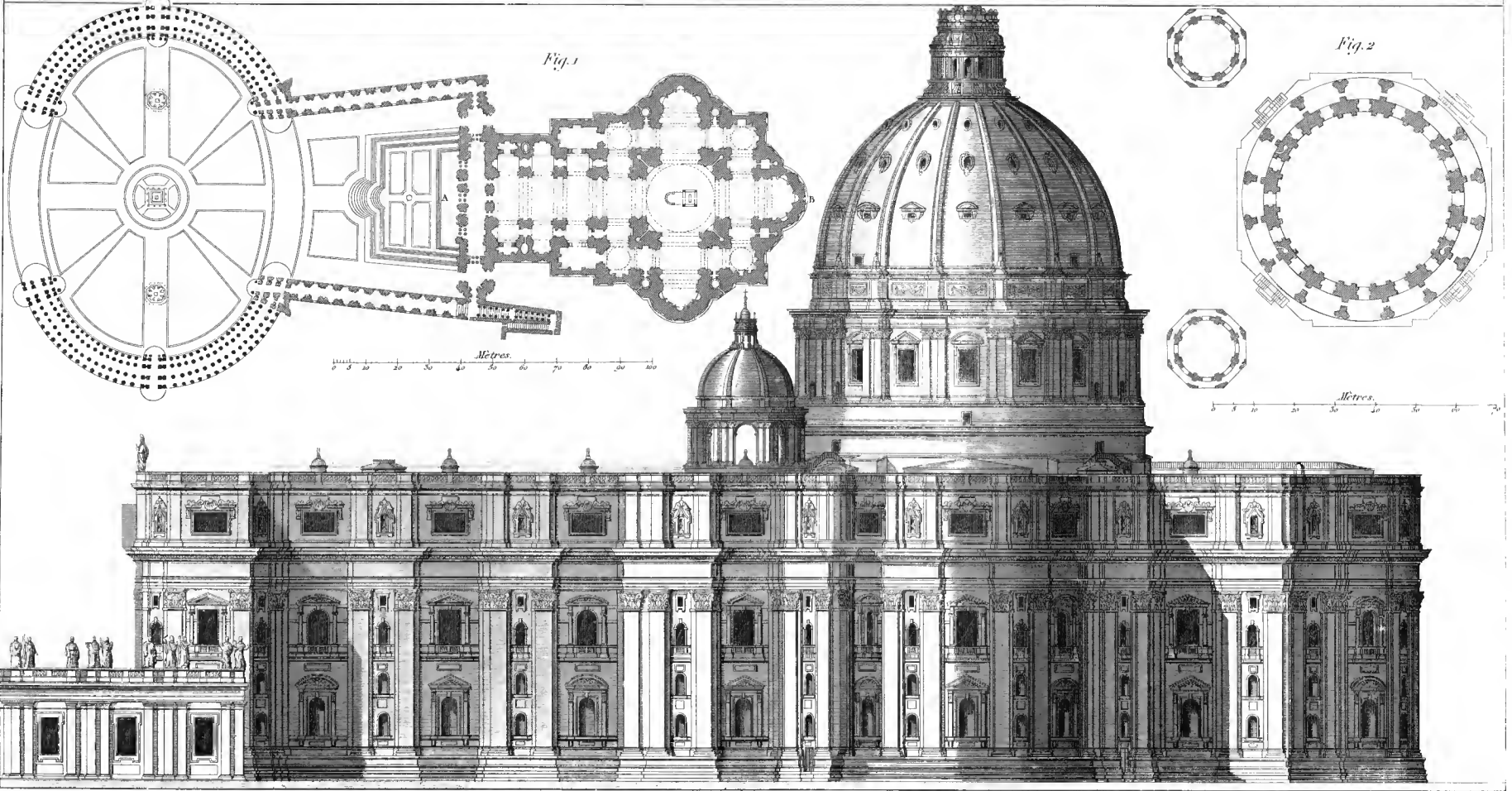


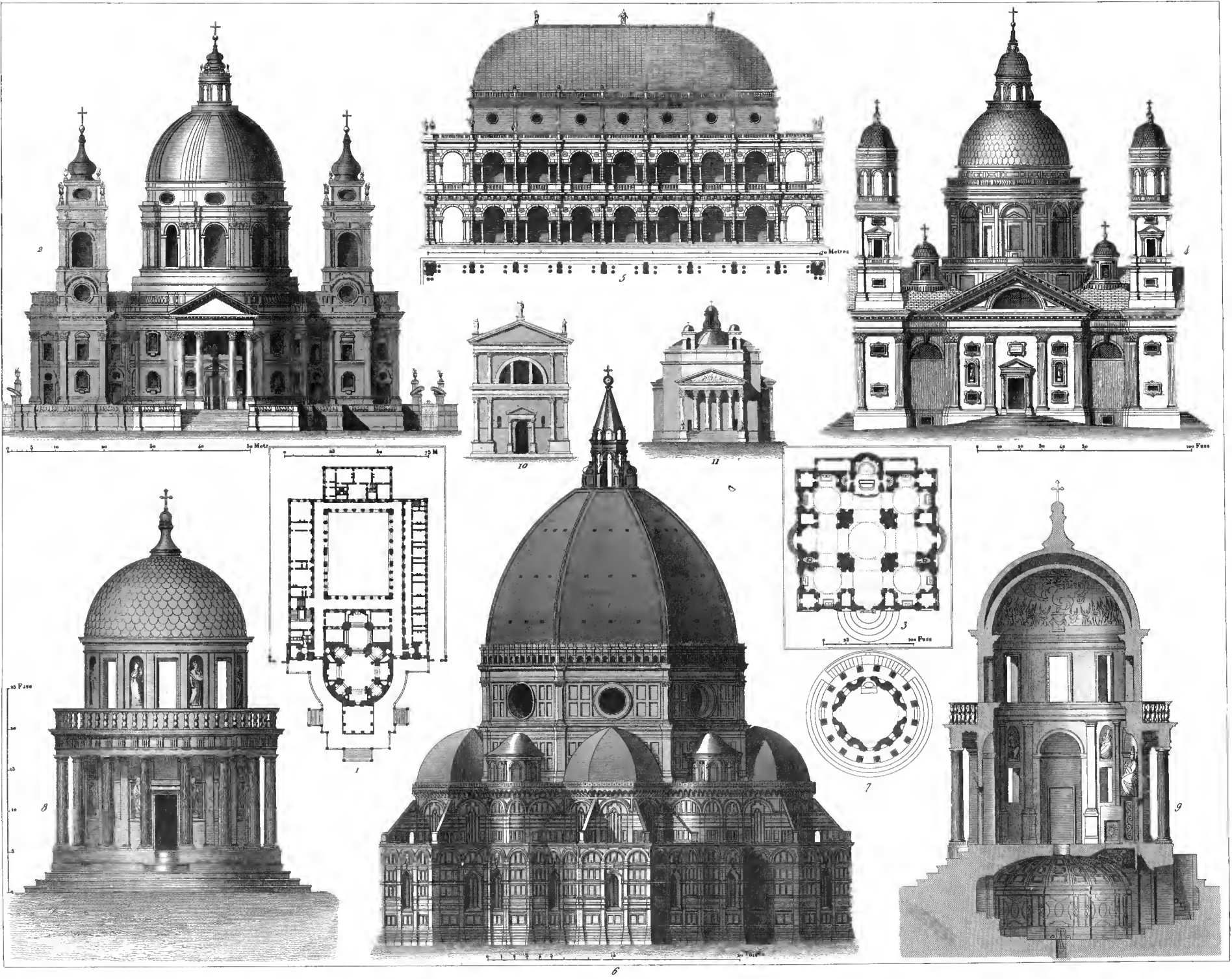




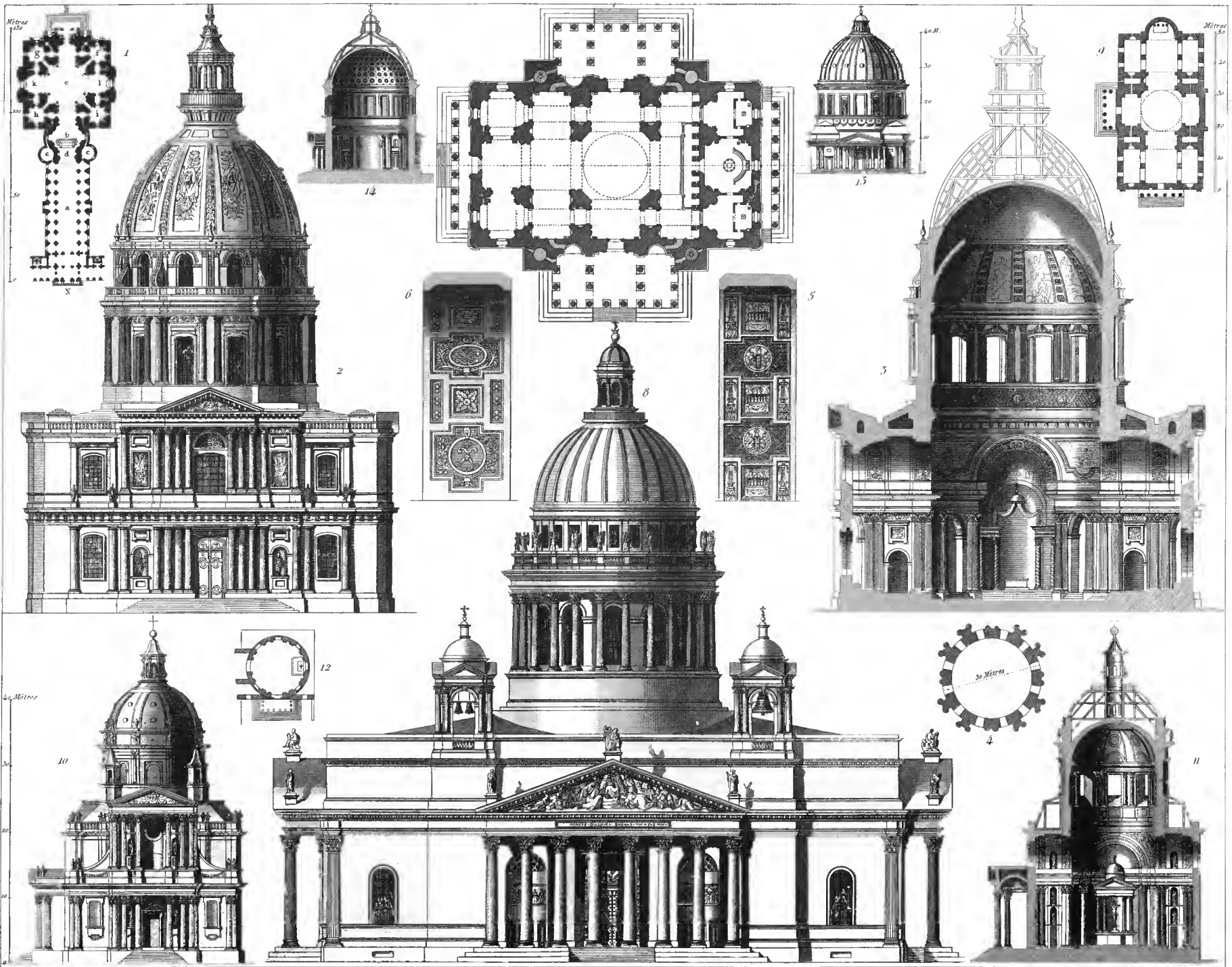


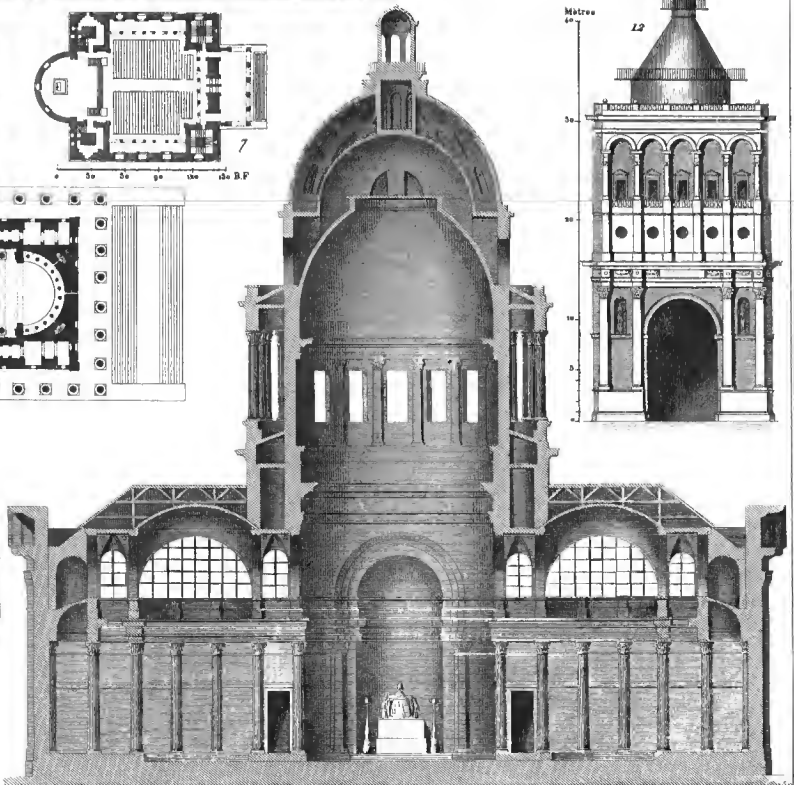
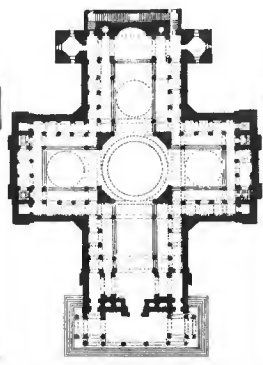
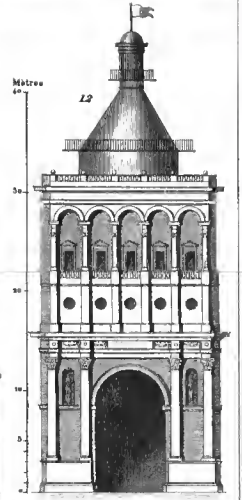
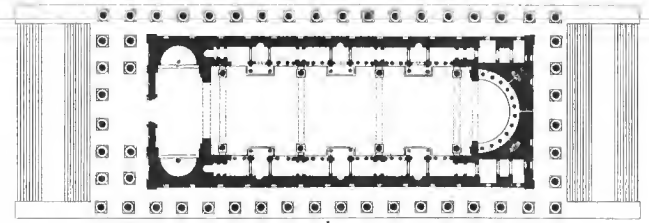
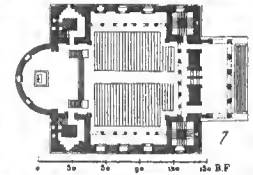
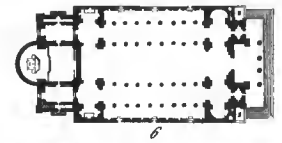
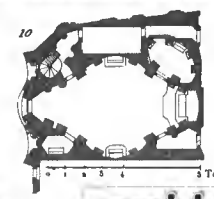
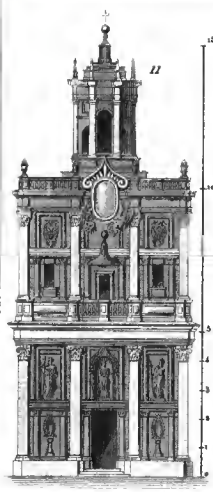
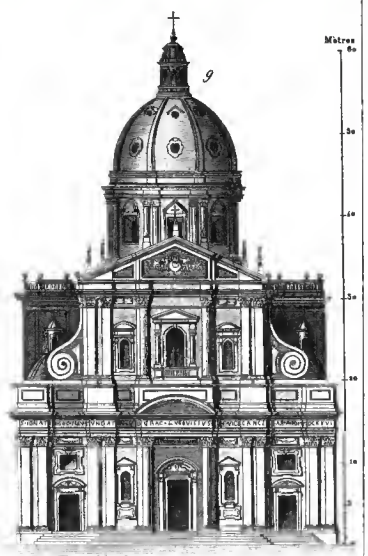
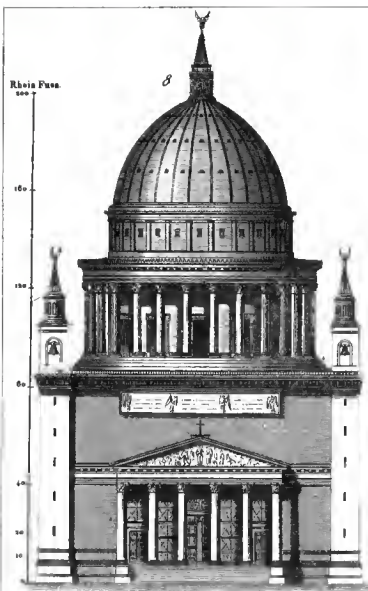
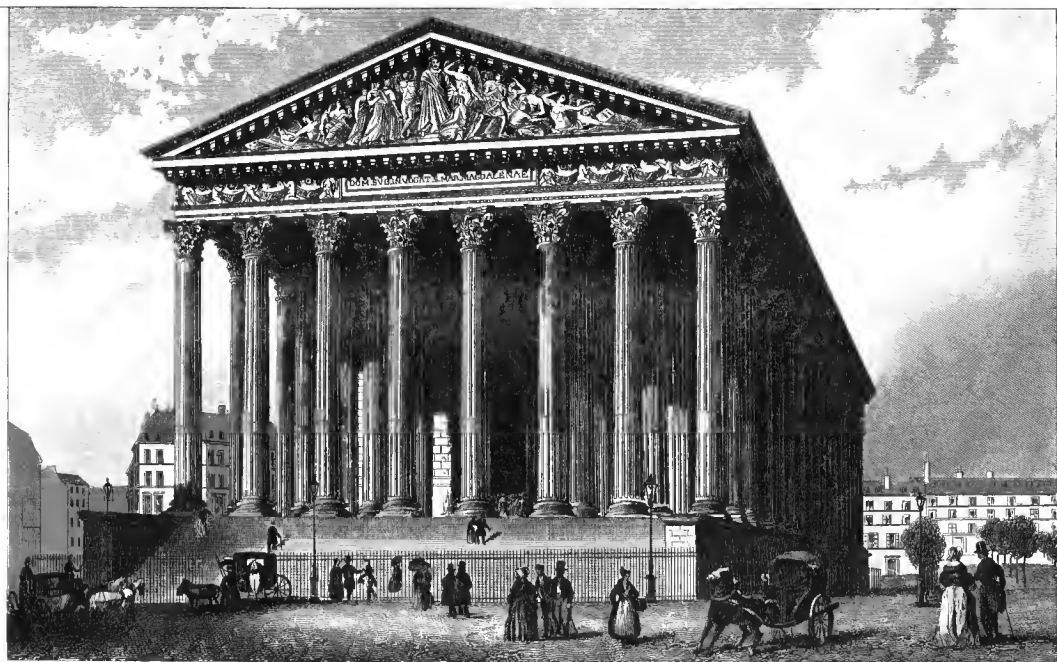












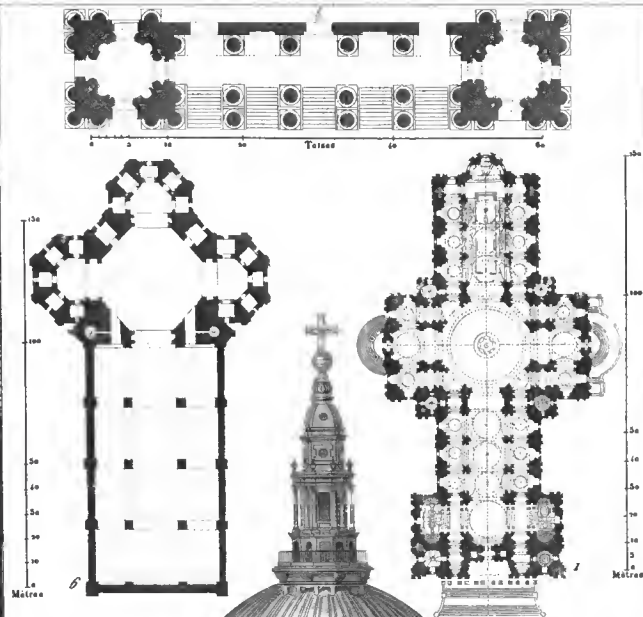
Maasstab für Fig 4 und 5

Maasstab für Fig 3

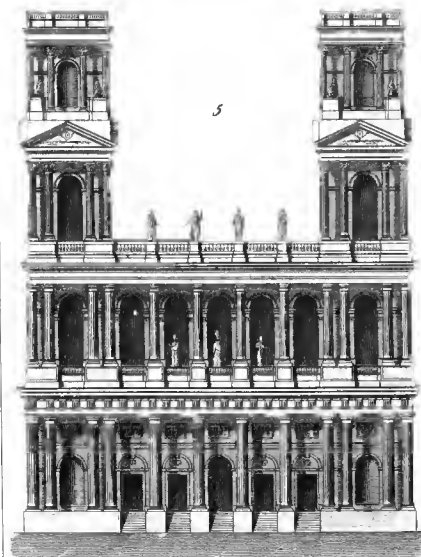
Henry Winkles sculp^d



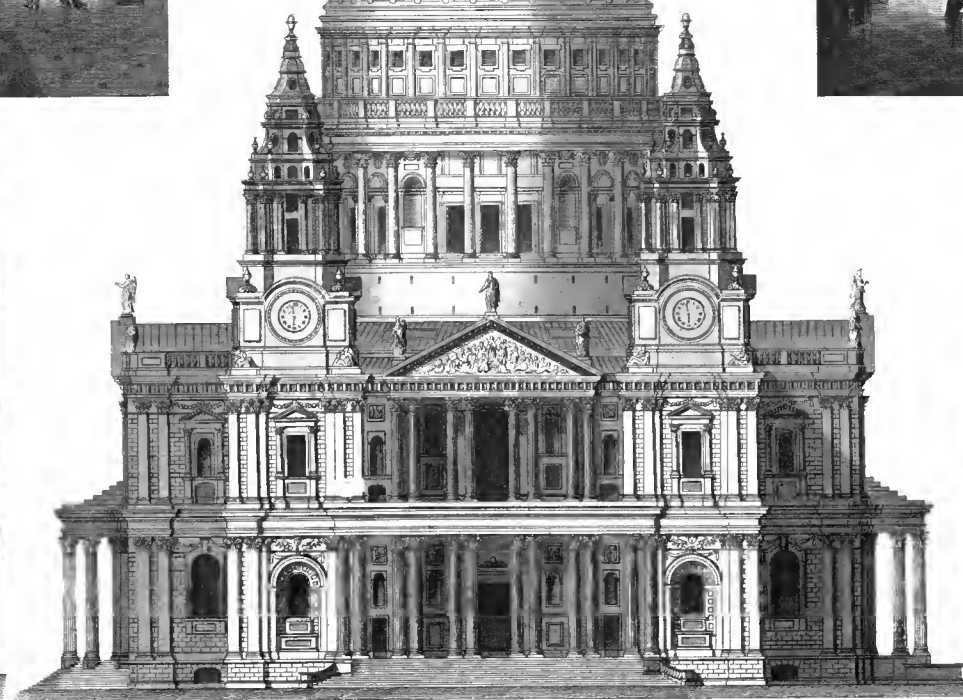
7



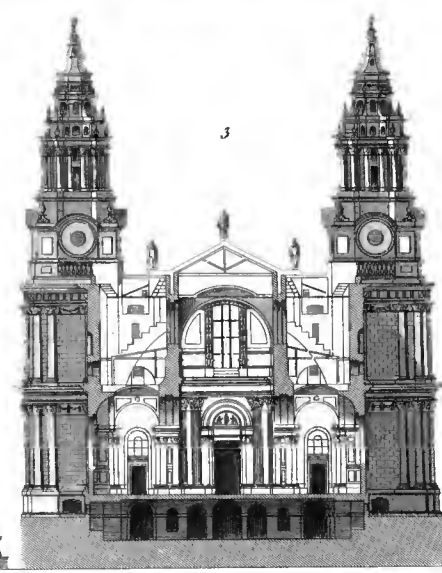
8



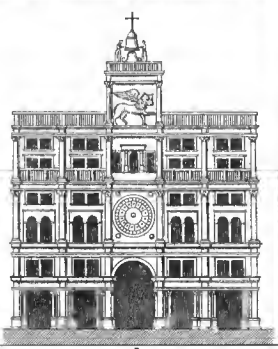
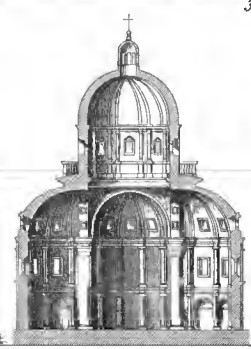
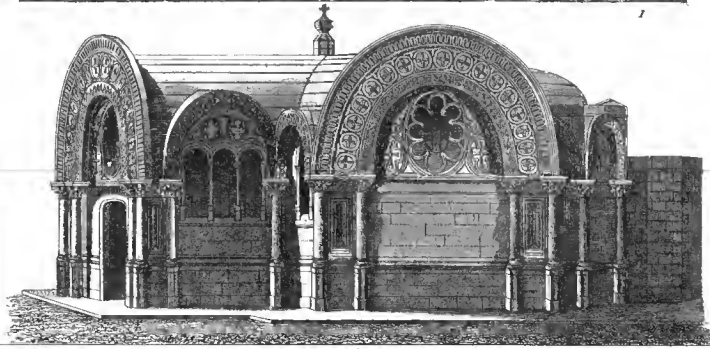
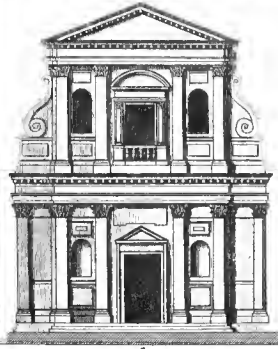
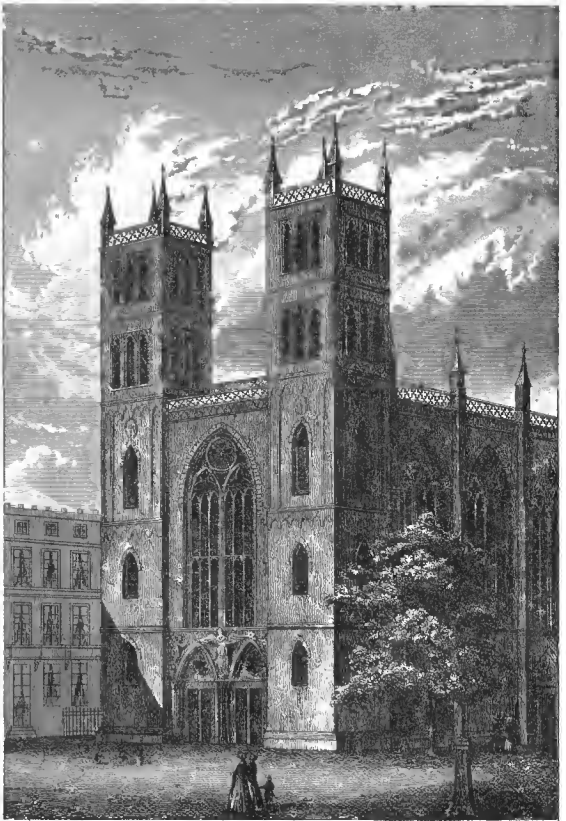
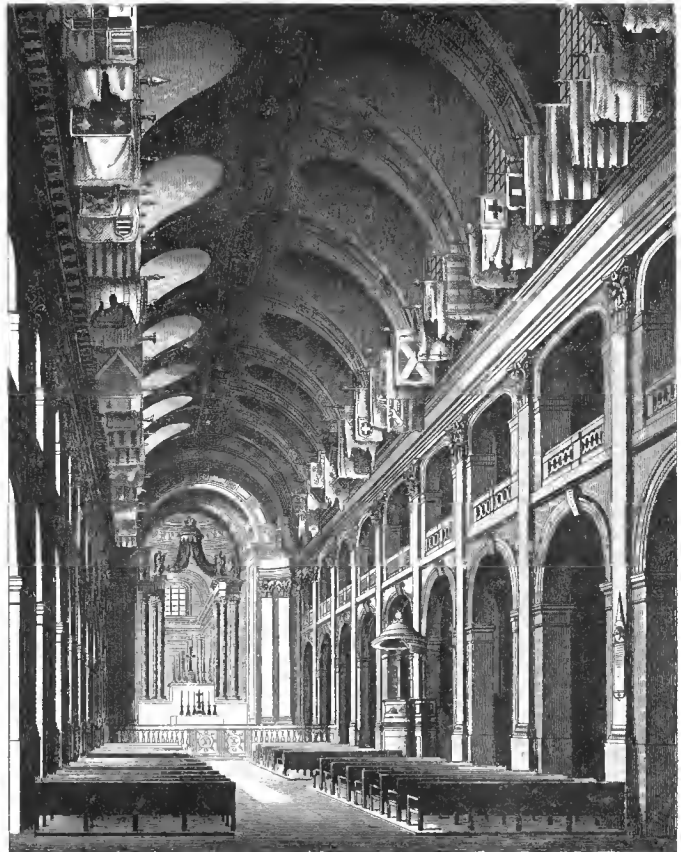
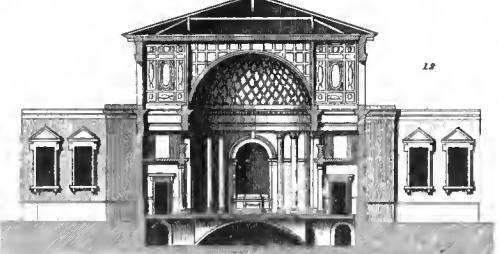
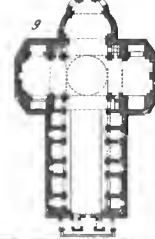
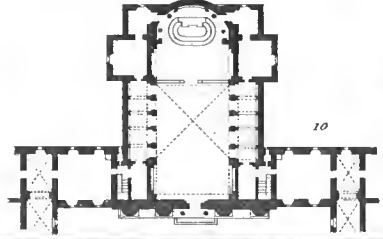
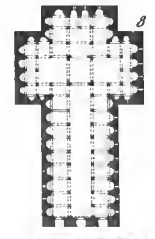
5

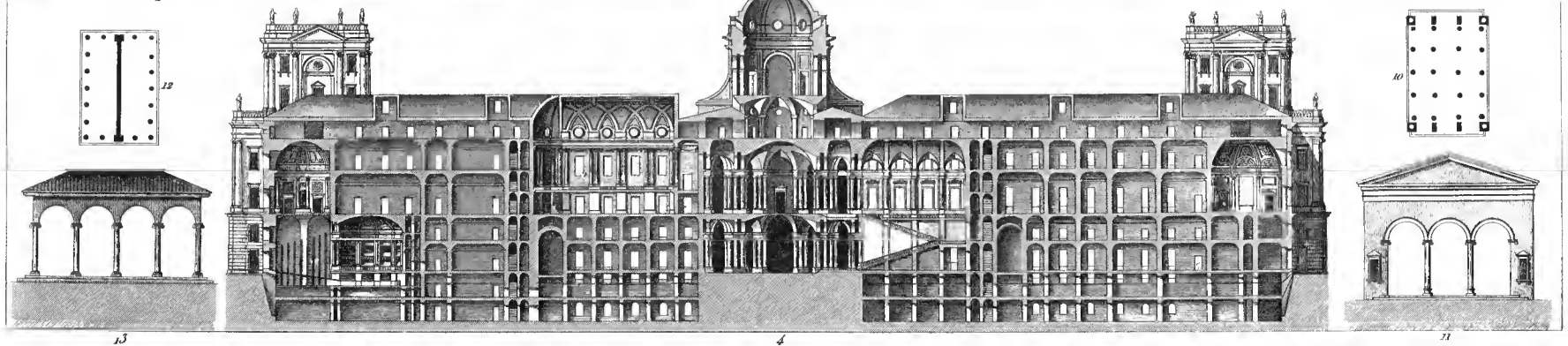
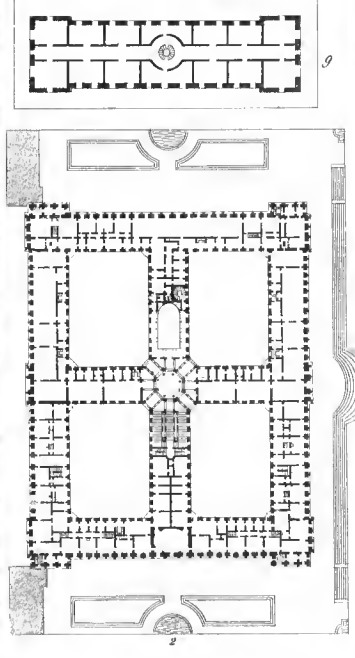
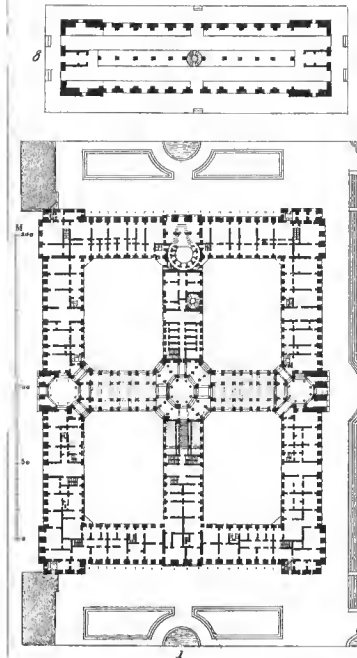
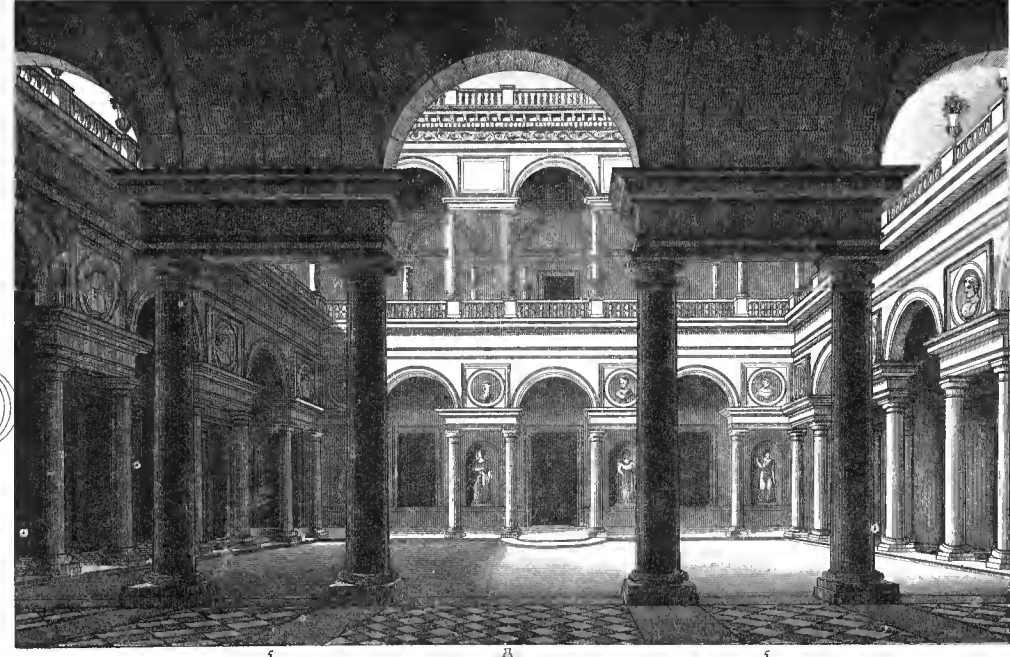
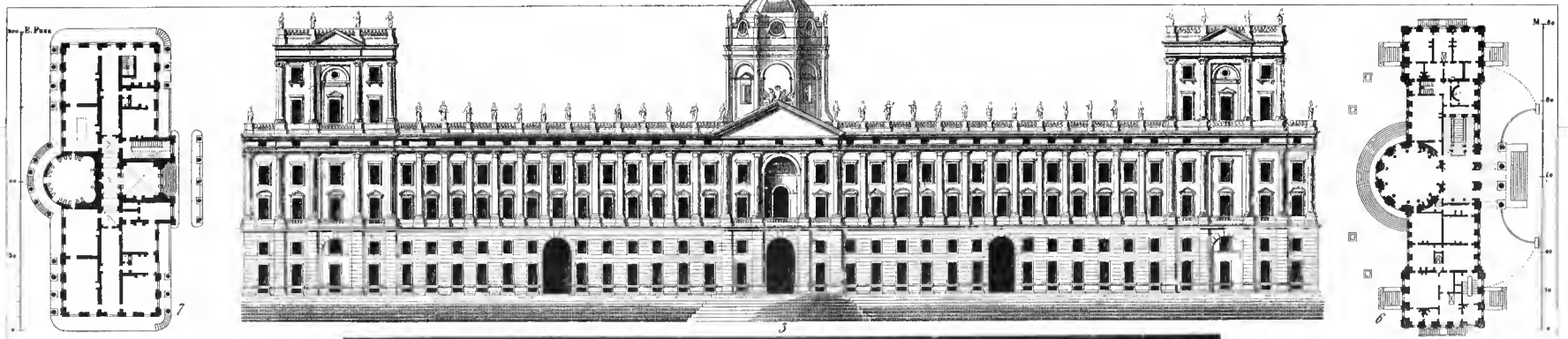


2



3

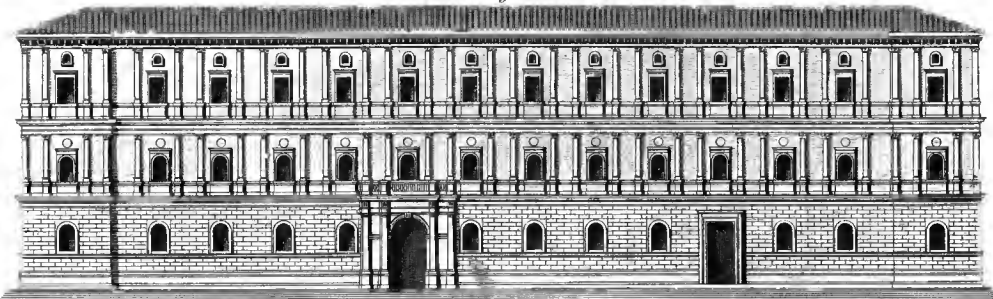
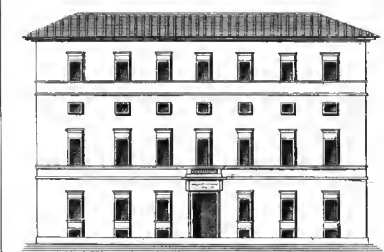
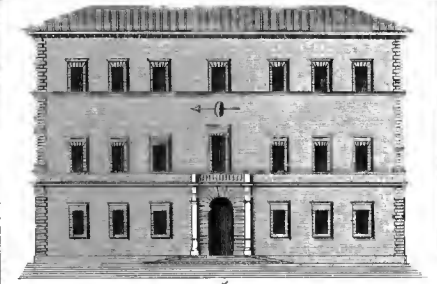
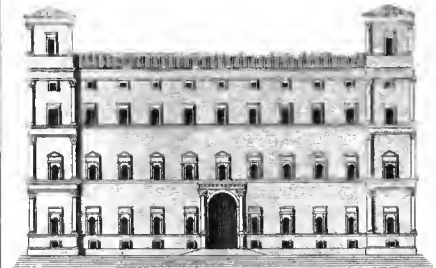
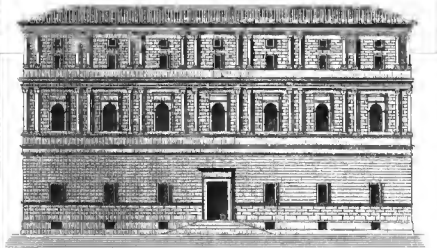
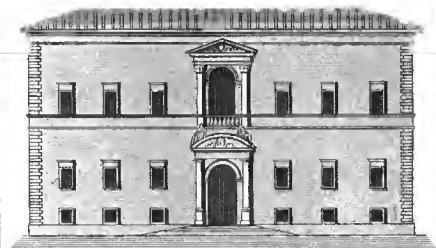
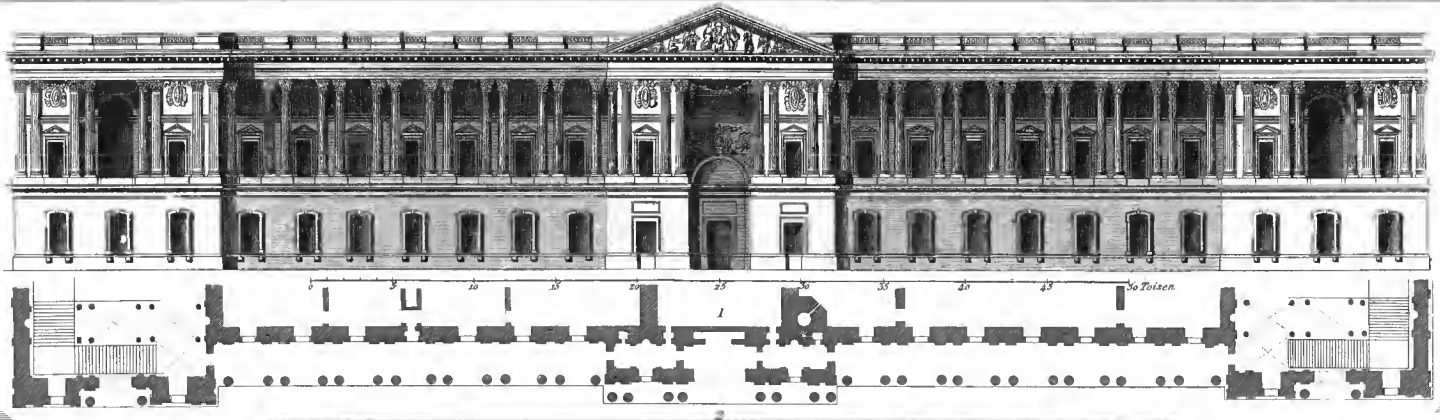
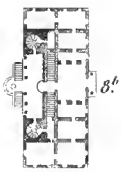


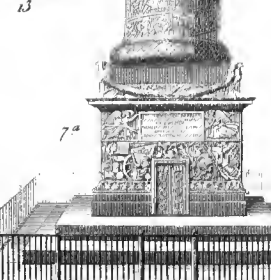
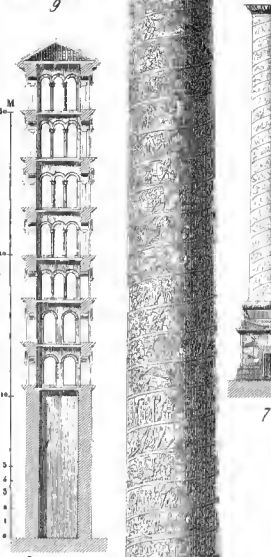
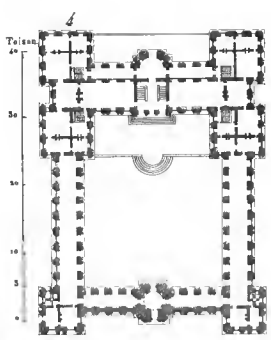


G. Heck del.

Masstab für Fig. 3 u. 4.

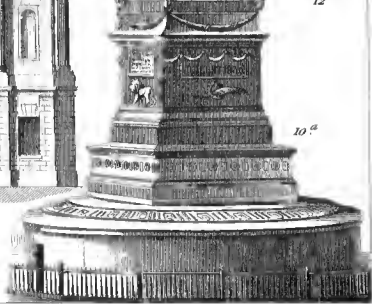
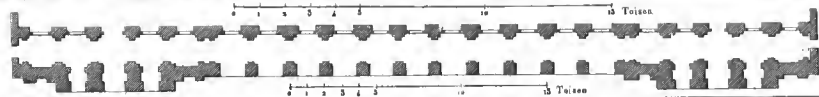
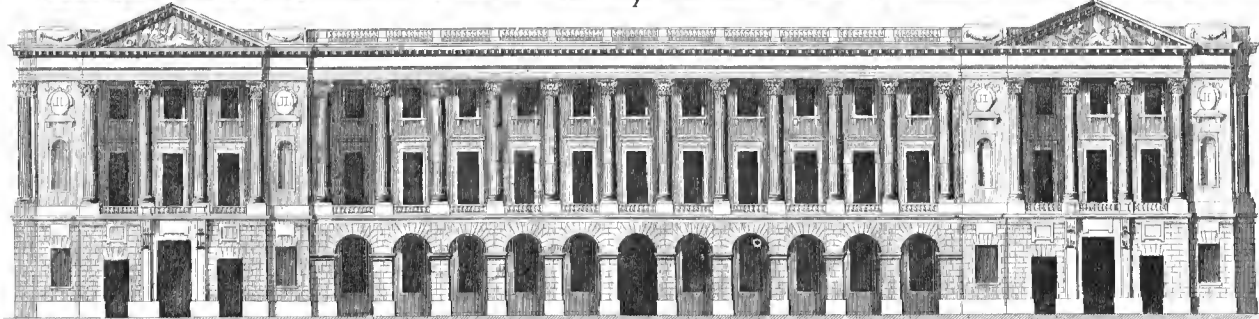
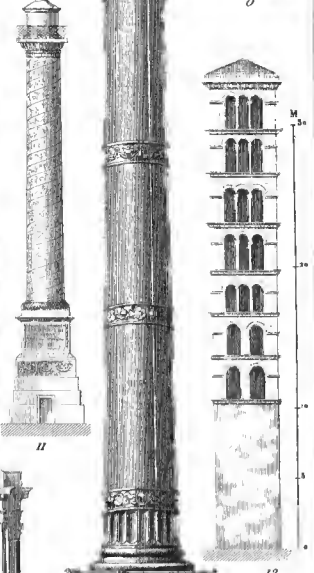
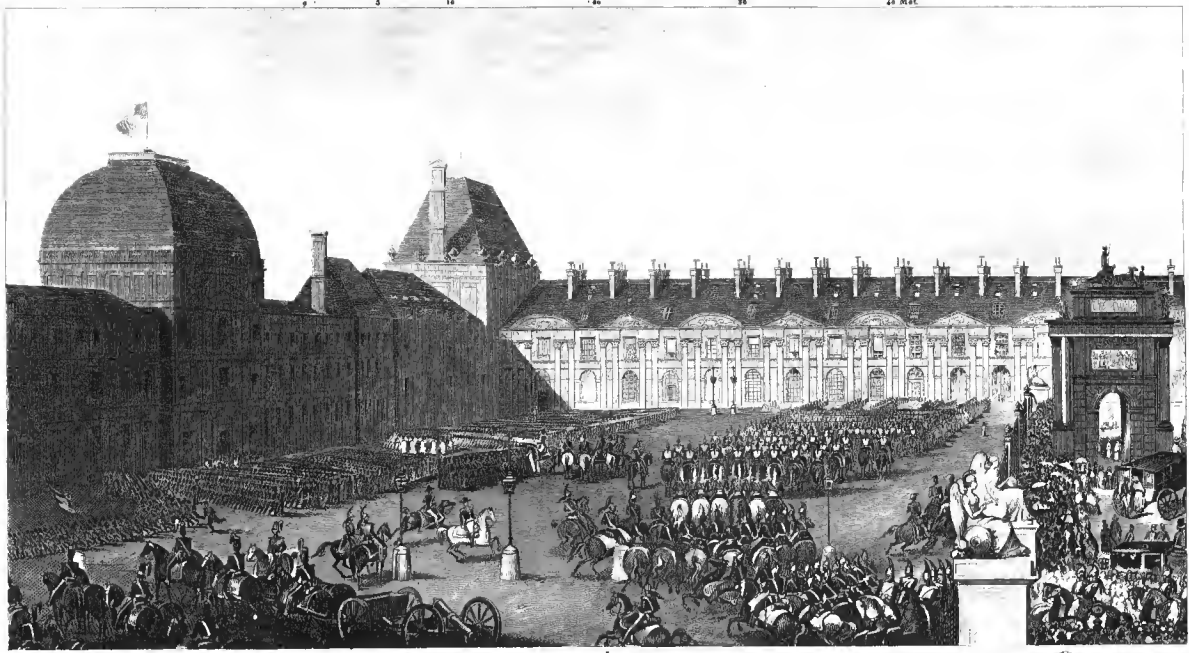
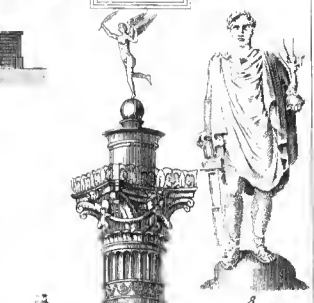
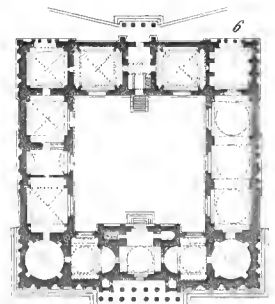
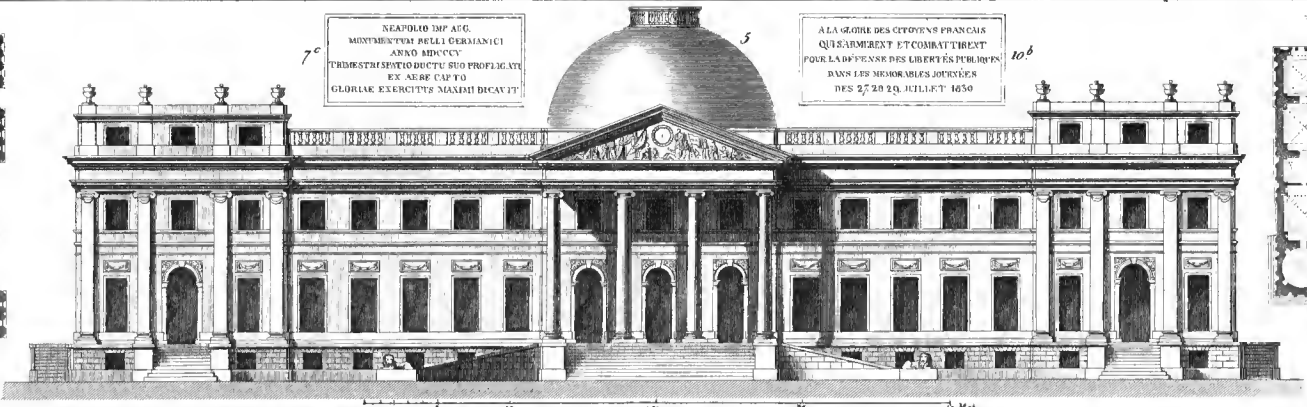
E. Krause jun. sculp.

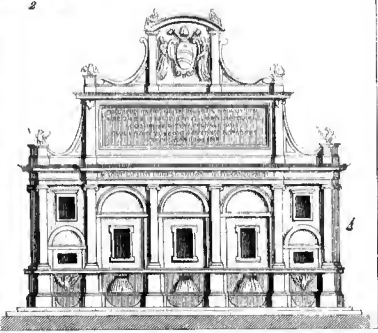
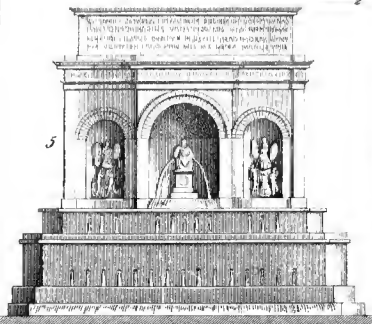
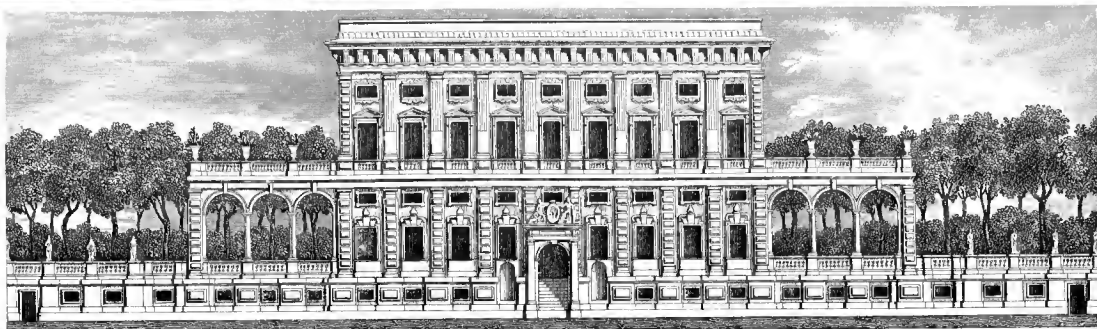
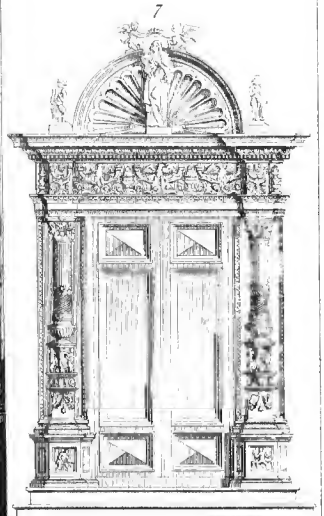
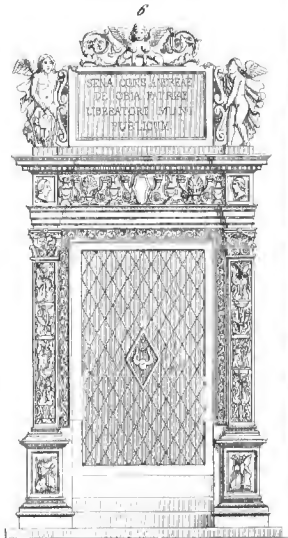
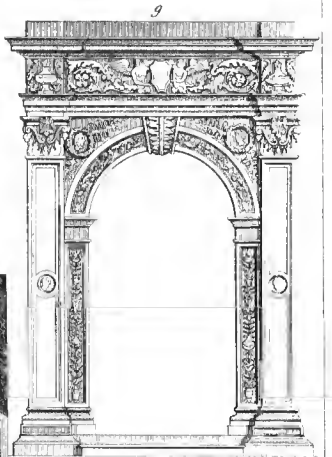
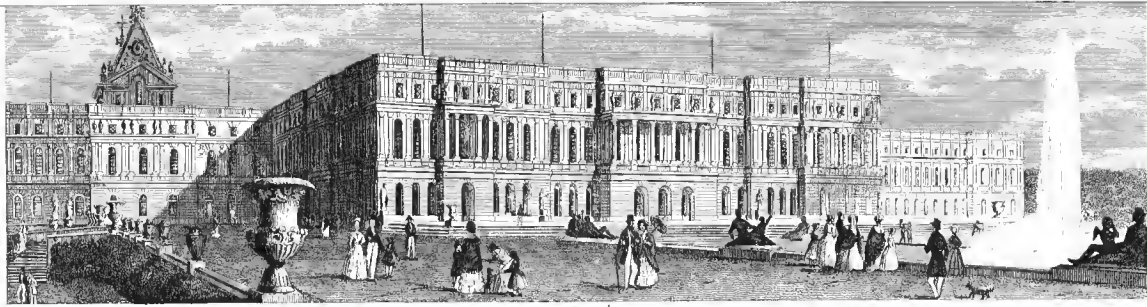


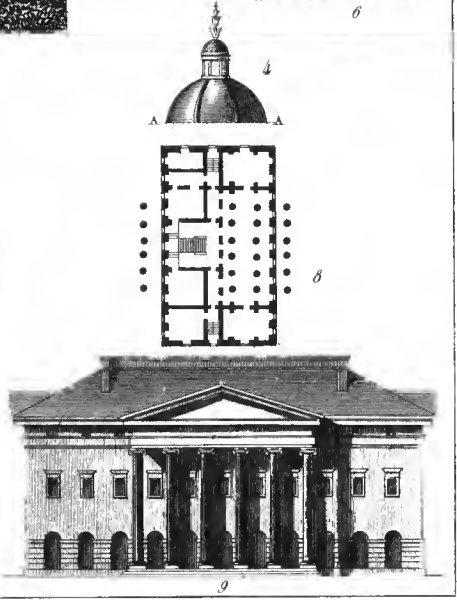
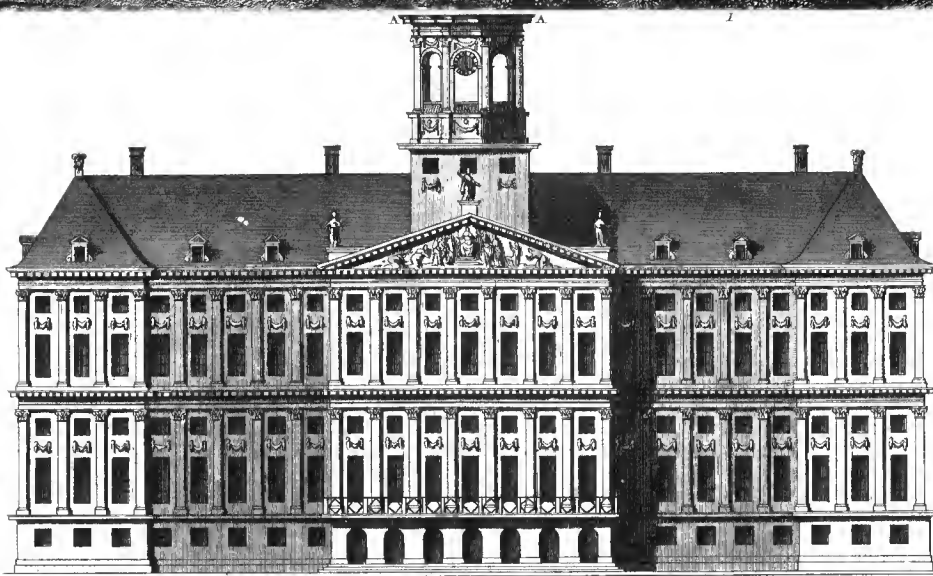
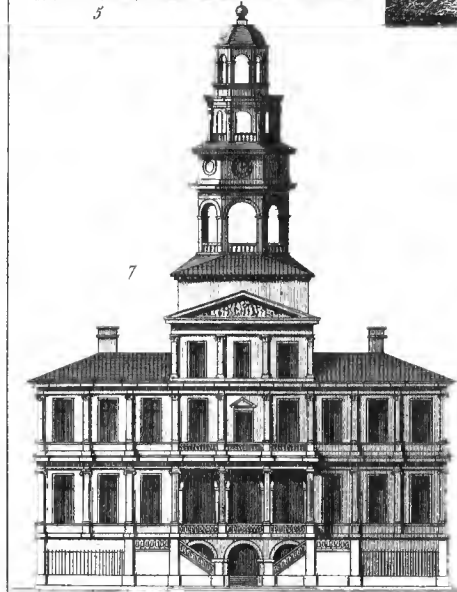
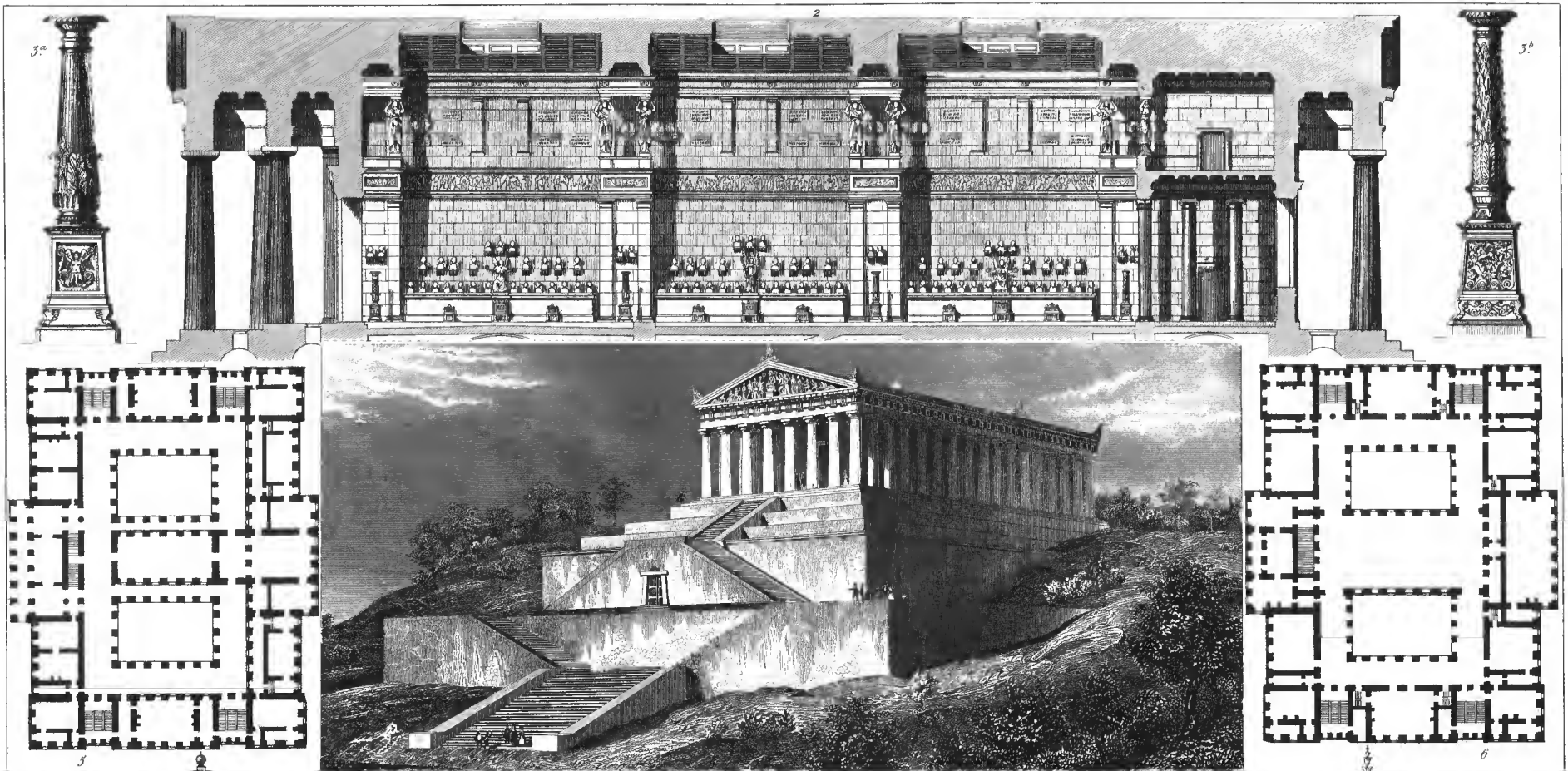


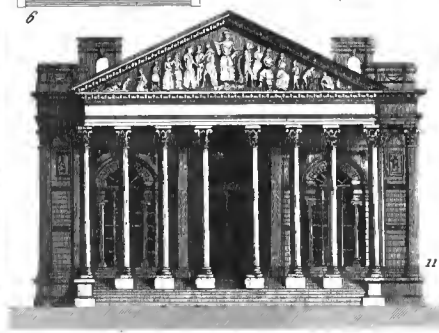
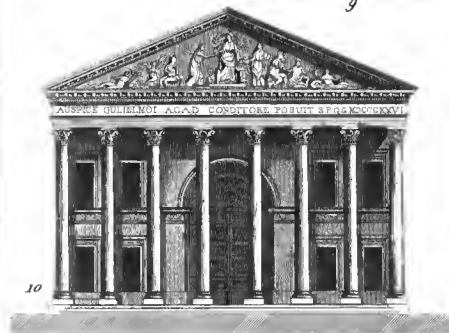
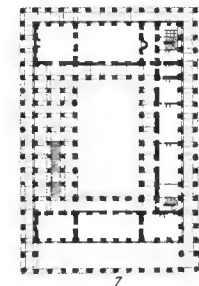
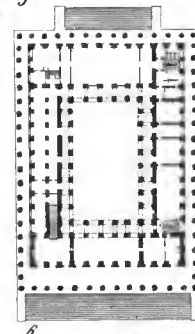
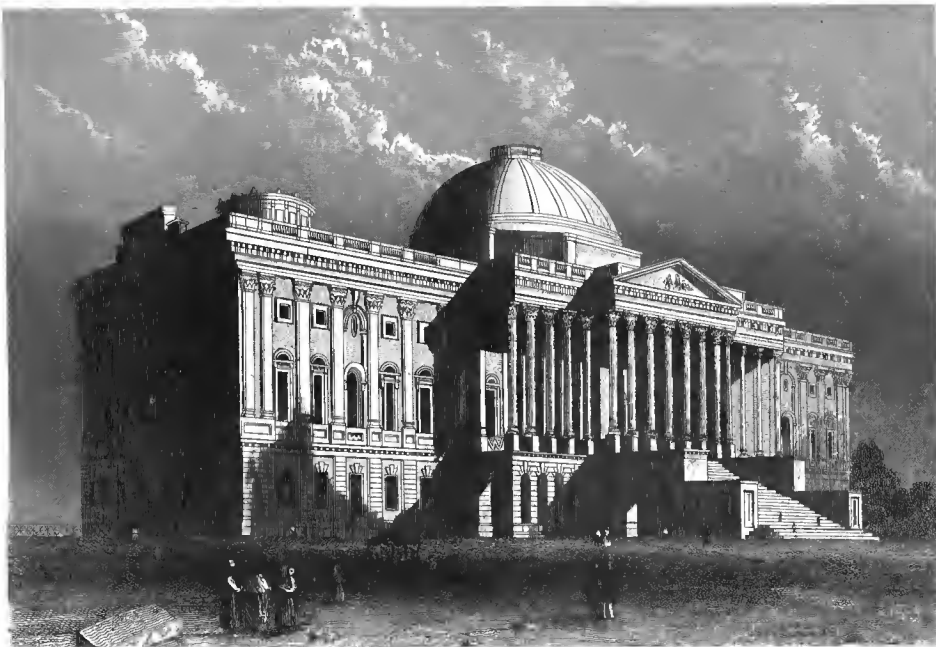
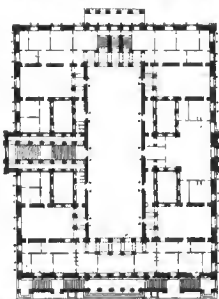
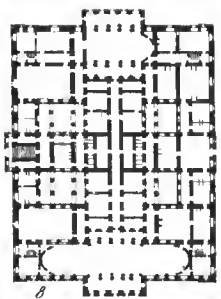
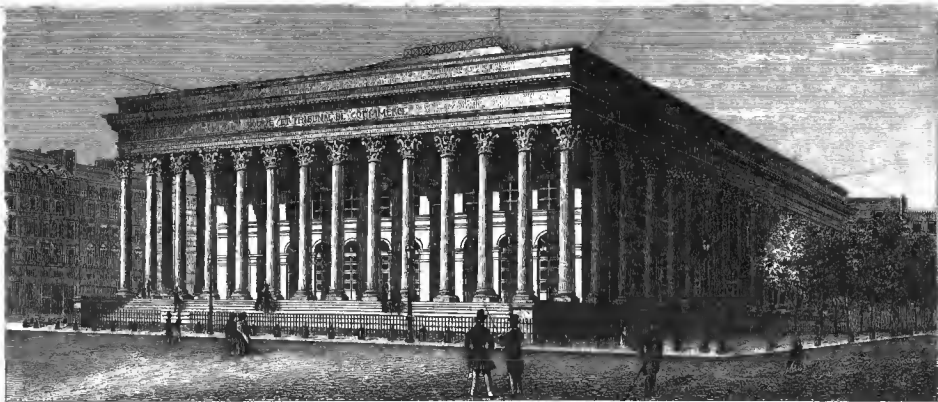
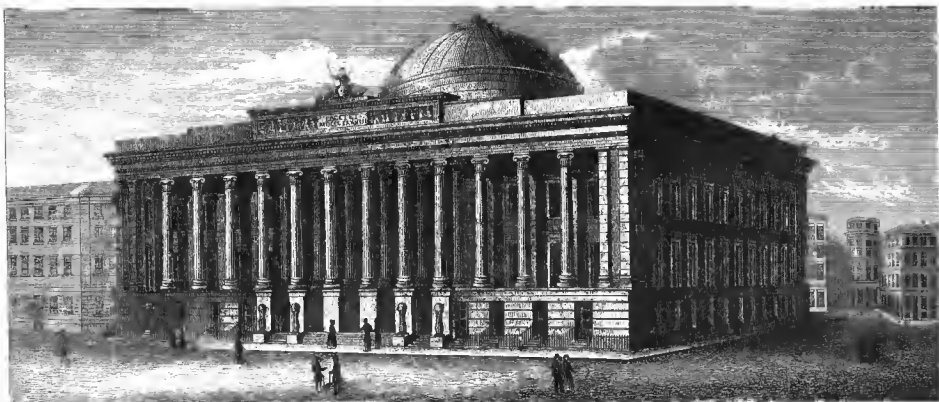
NEAPOLIO IMP. AEG.
 MONUMENTUM BELLI GERMANICI
 ANNO MDCCC
 TRIDESTRUMENTO DICTO SIO PROFICUAT
 EX AERE CAPTO
 GLORIAE EXERCITUS MAXIMI DICAVIT

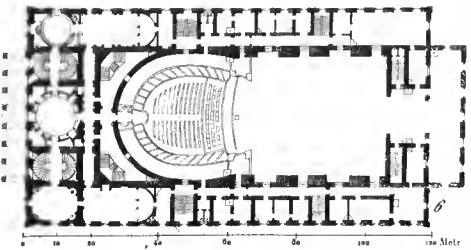
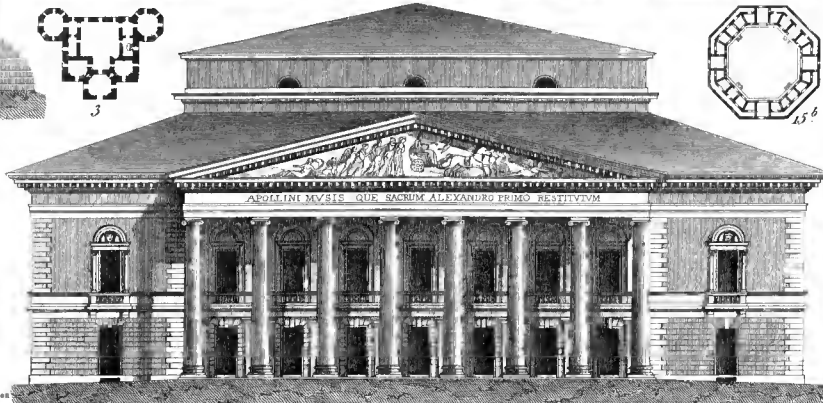
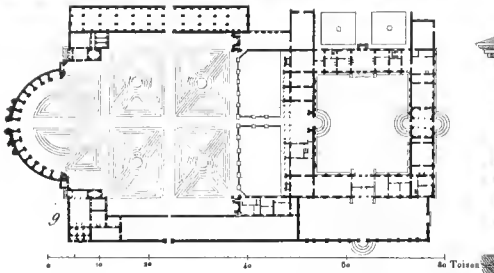
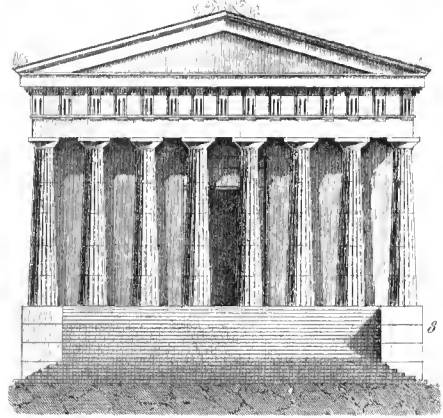
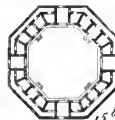
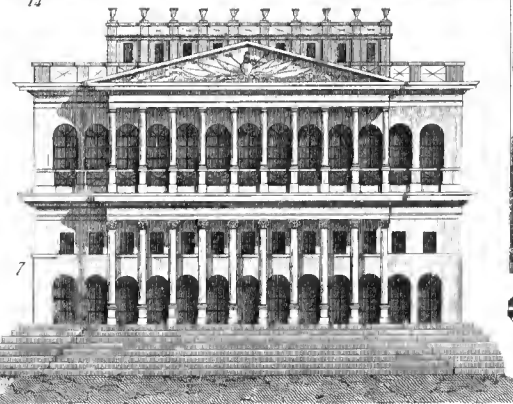
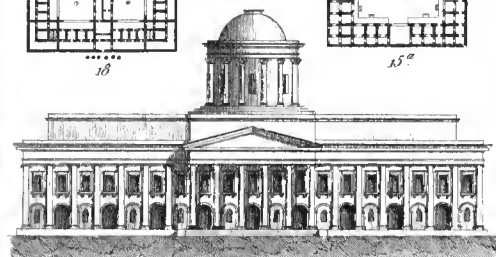
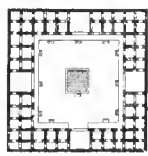
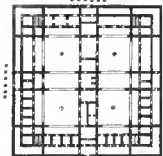
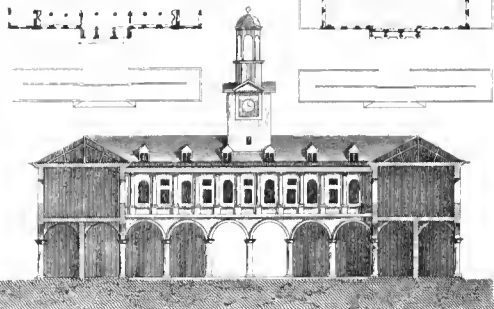
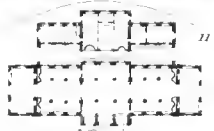
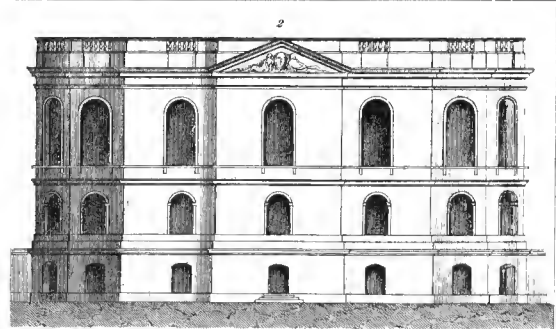
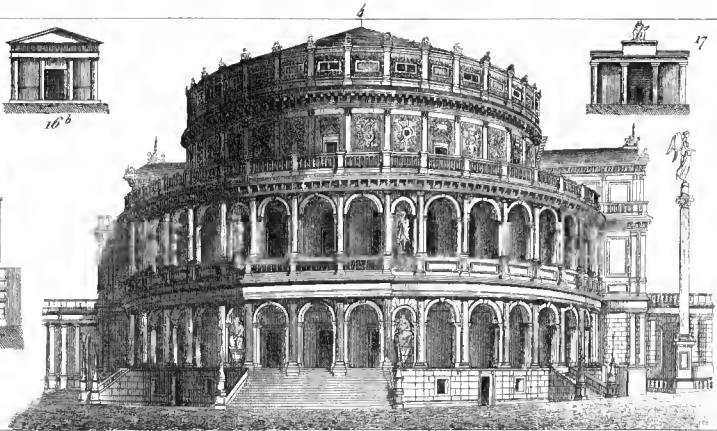
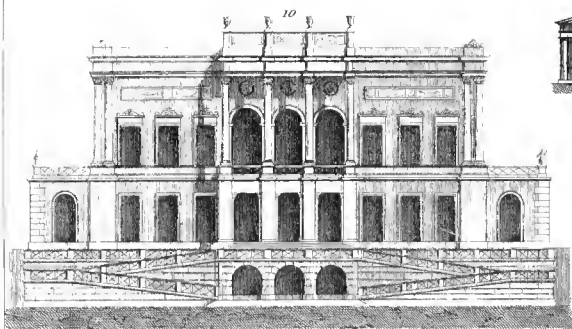
A LA GLOIRE DES CITOYENS FRANCAIS
 QUI S'ARMERENT ET COMBAT TIRENT
 POUR LA DEFENSE DES LIBERTES PUBLIQUES
 DANS LES MEMORABLES JOURNEES
 DES 27, 28, 29, JUILLET 1830









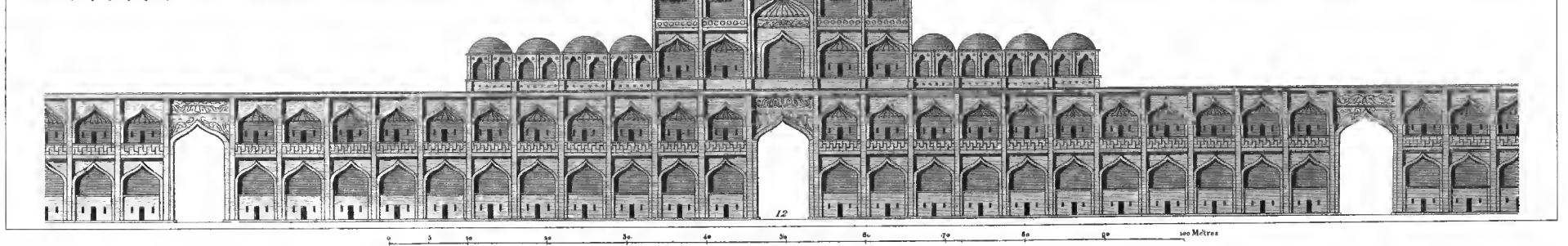
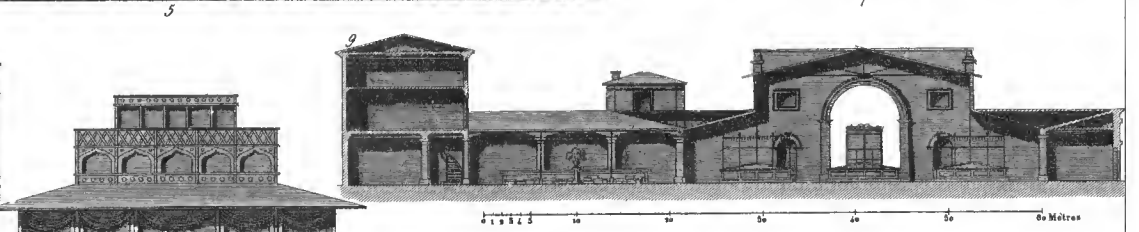
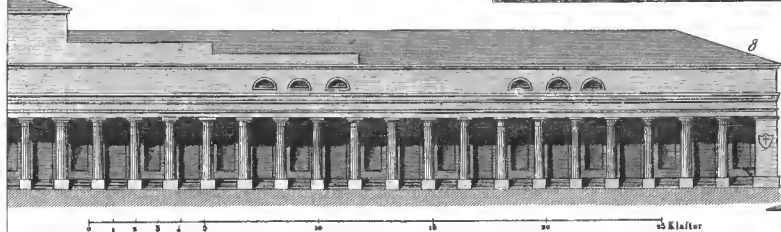
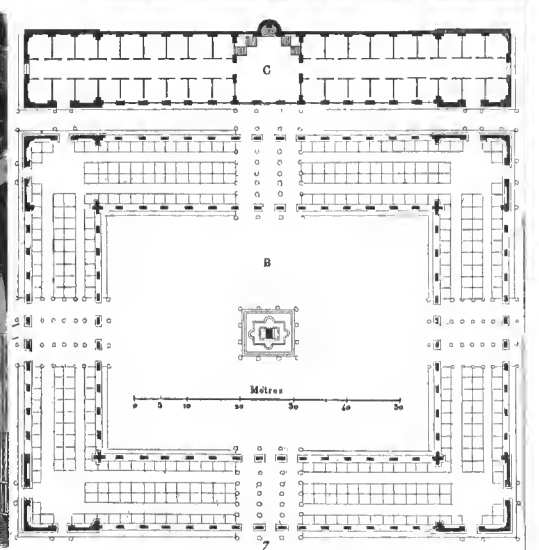
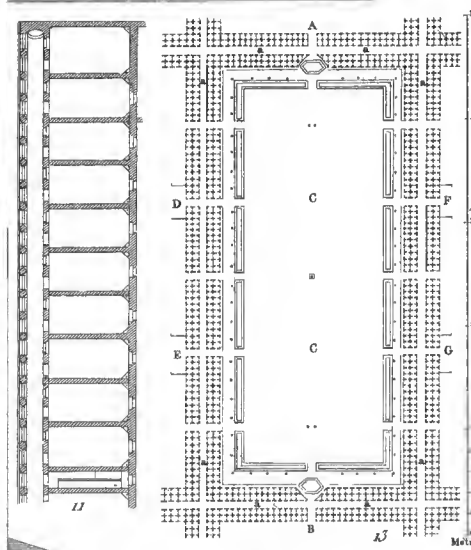
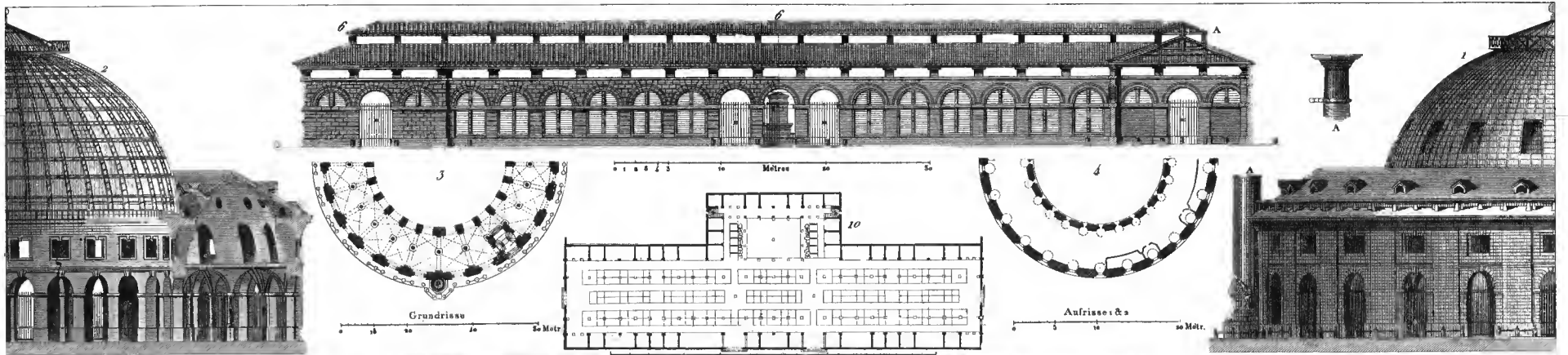


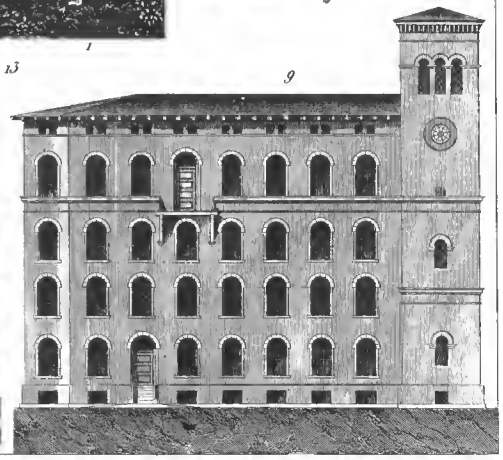
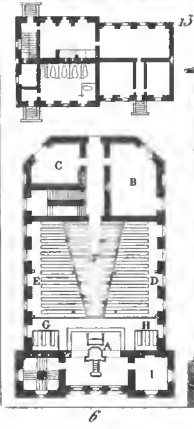
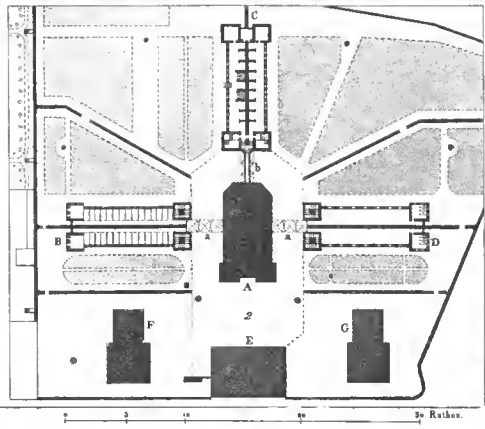
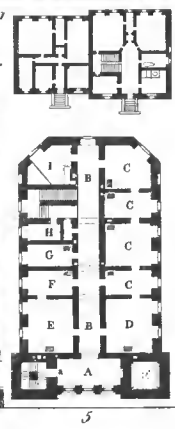
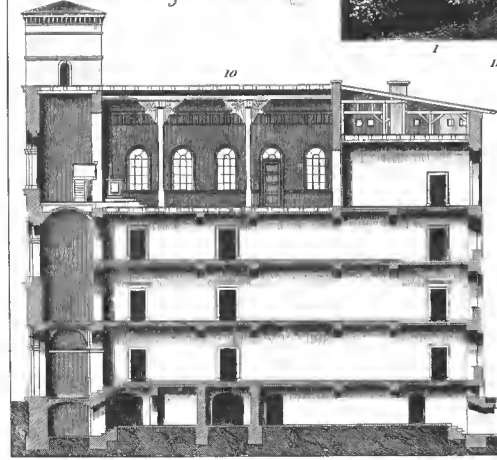
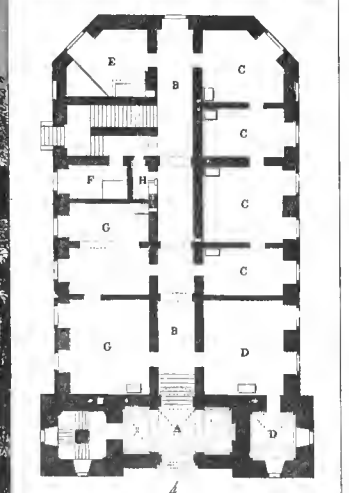
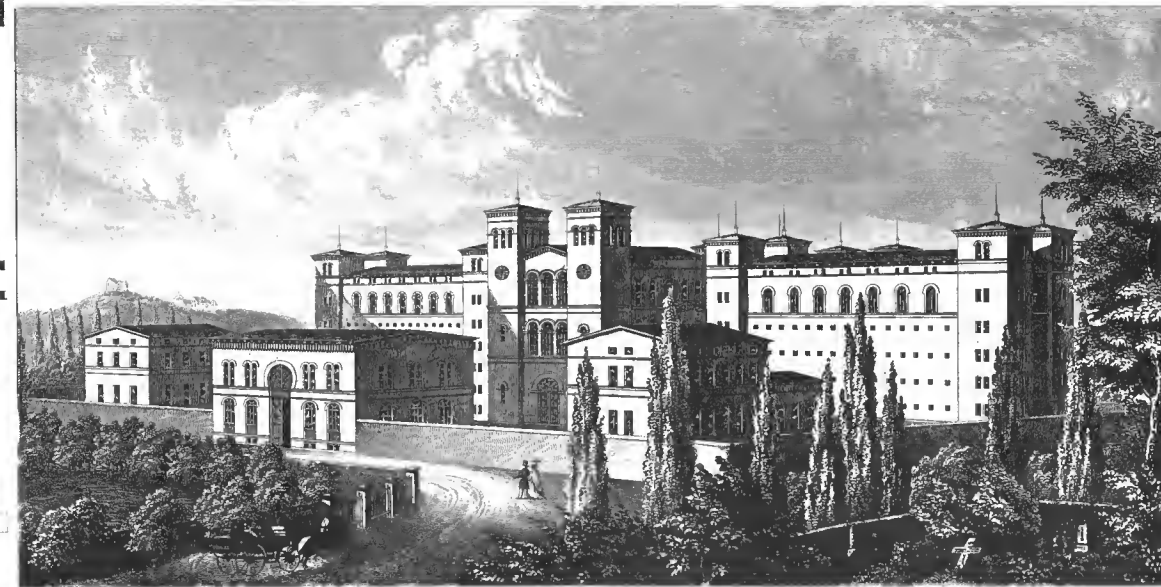
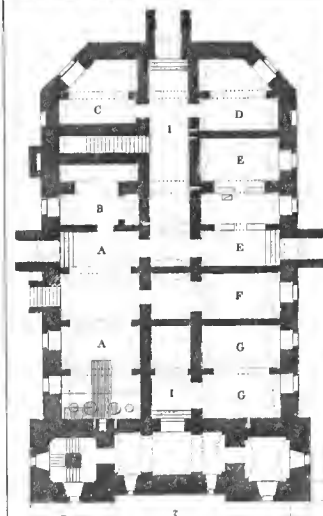
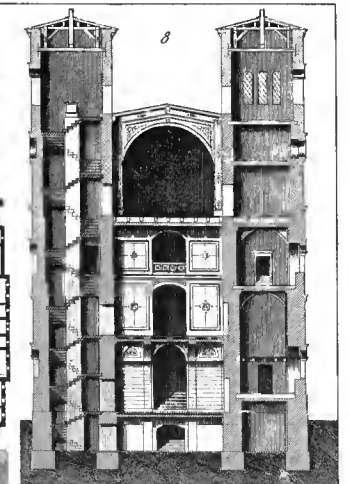
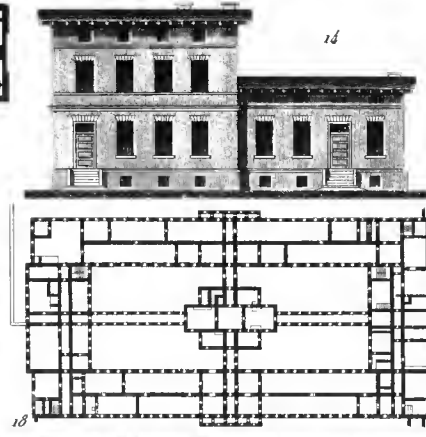
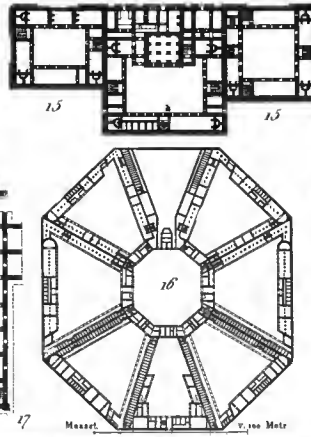
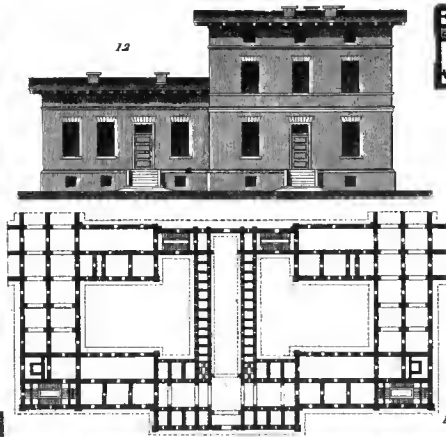
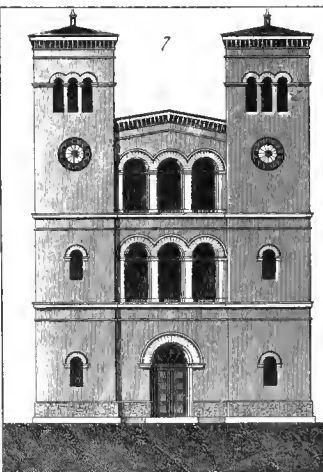
Maasstab für Fig 2

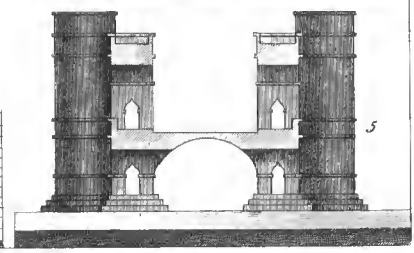
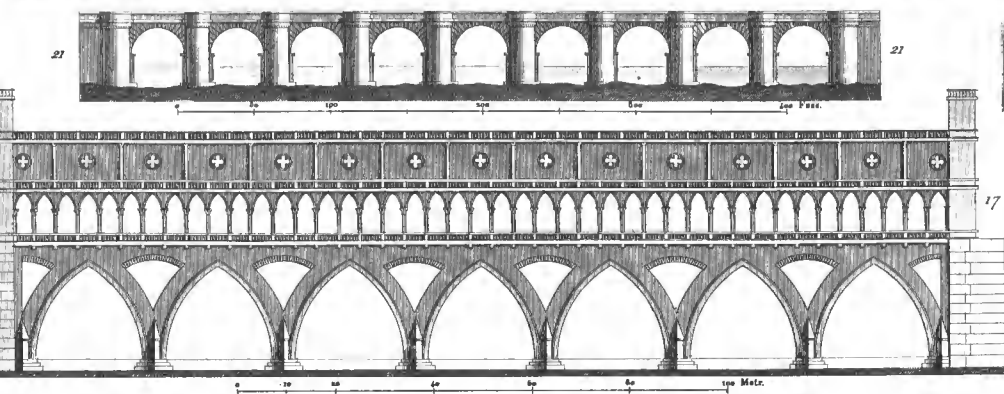
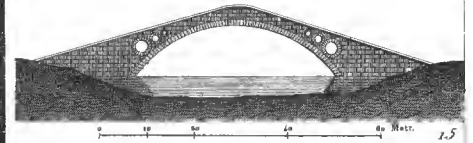
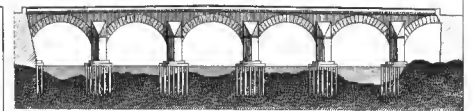
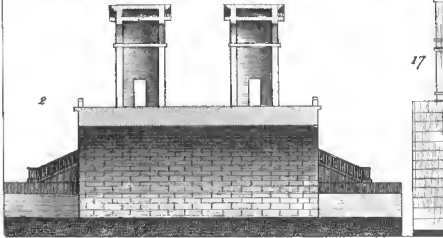
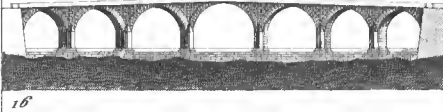
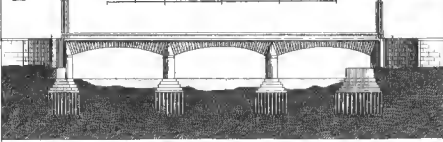
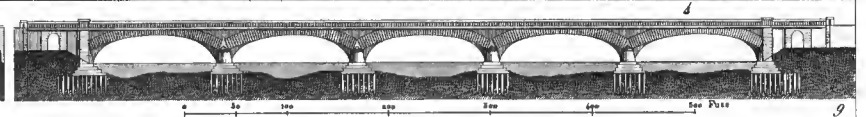
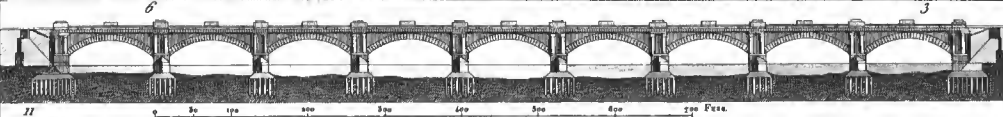
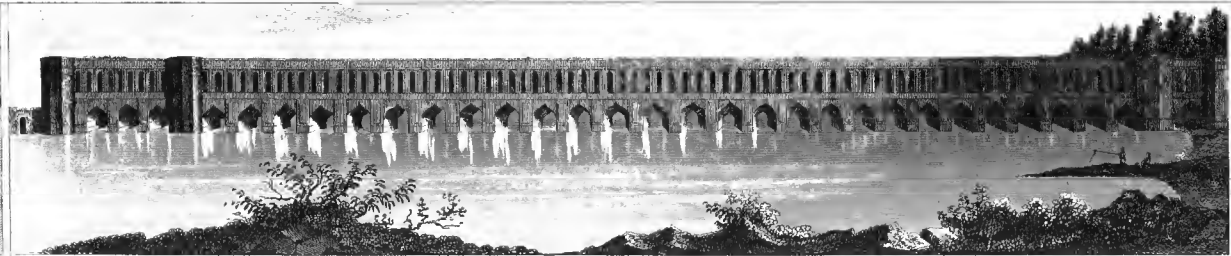
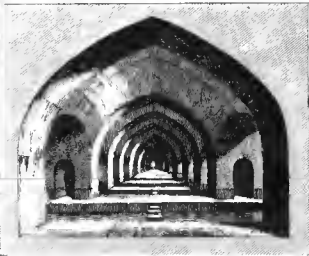
Maasstab für Fig 16


0 10 20 30 40 Metres

0 10 20 30 40 50 60 70 80 90 100 Metres










ICONOGRAPHIC
E N C Y C L O P Æ D I A .

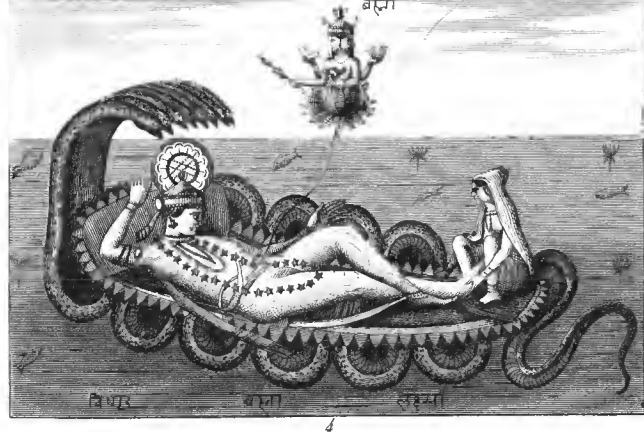
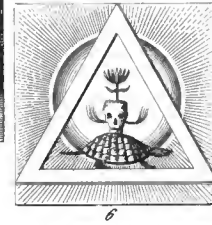
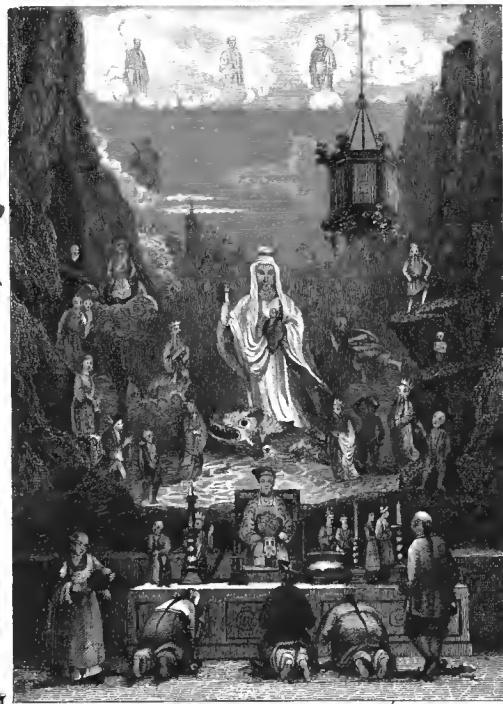
DIVISION VIII.

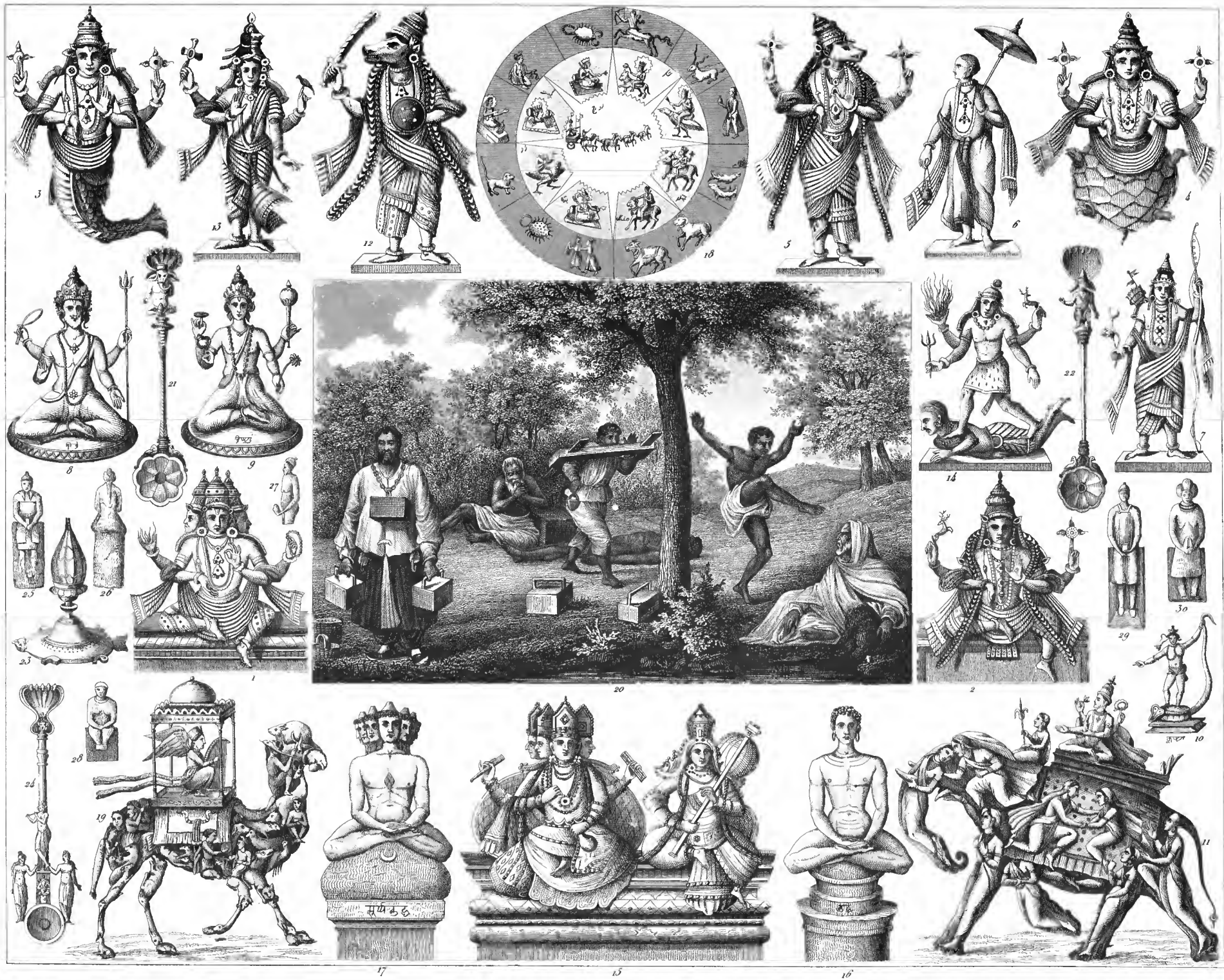
MYTHOLOGY AND RELIGIOUS RITES.

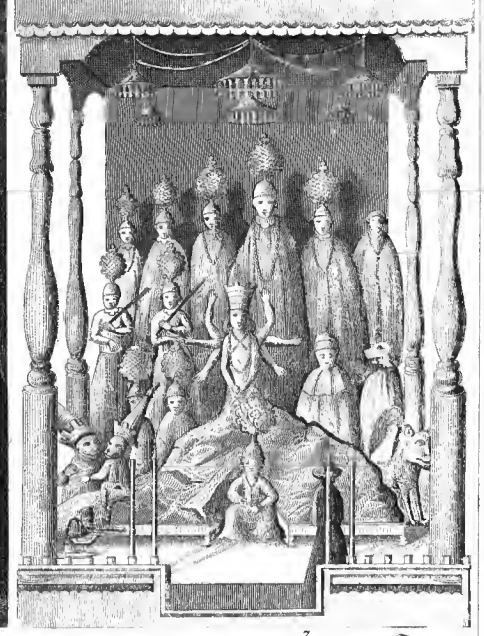
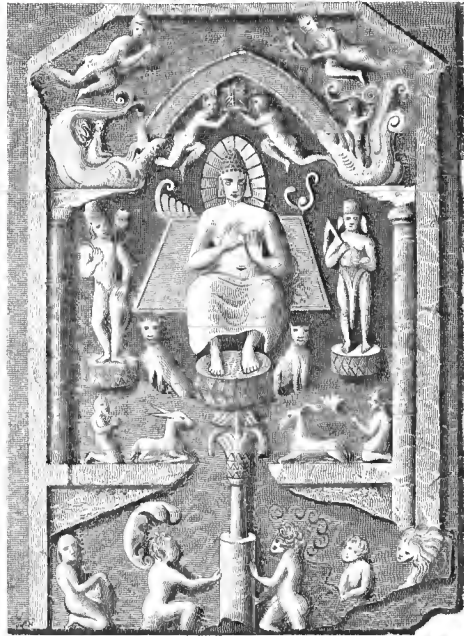
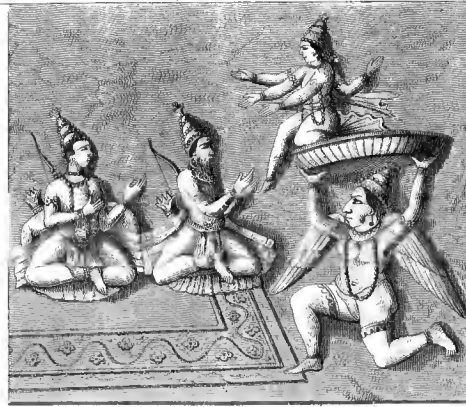
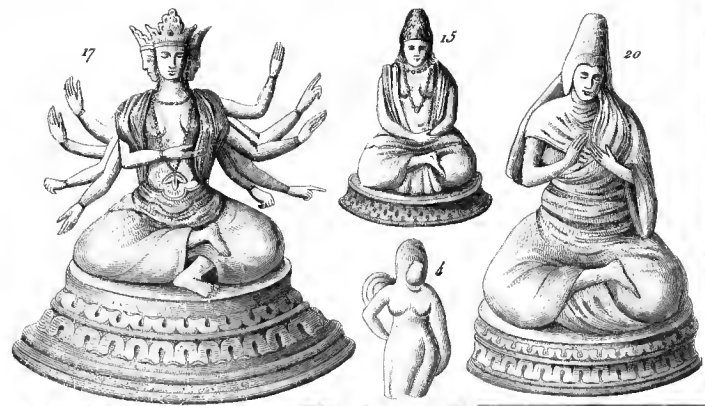
THIRTY PLATES.

NEW YORK: 1851.
PUBLISHED BY RUDOLPH GARRIGUE,
2 BARCLAY STREET (ASTOR HOUSE).



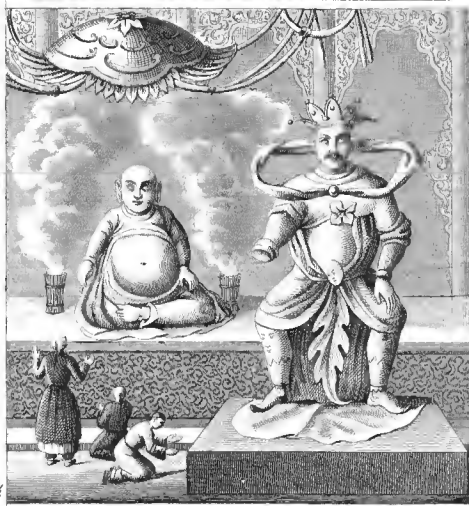




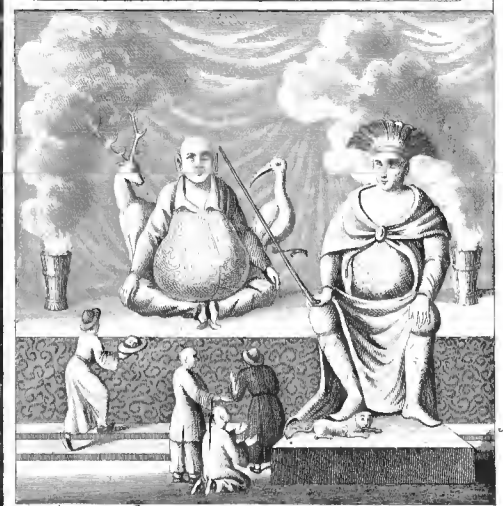




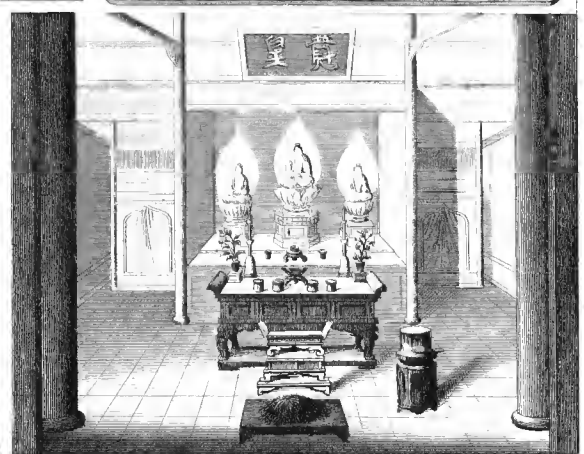
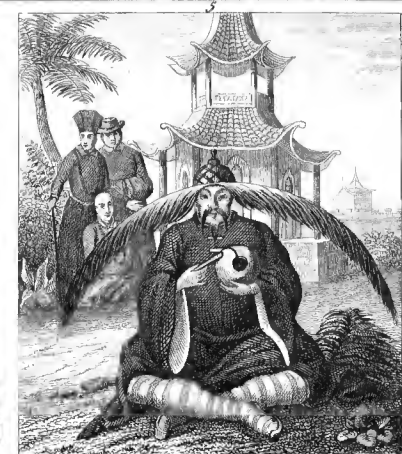
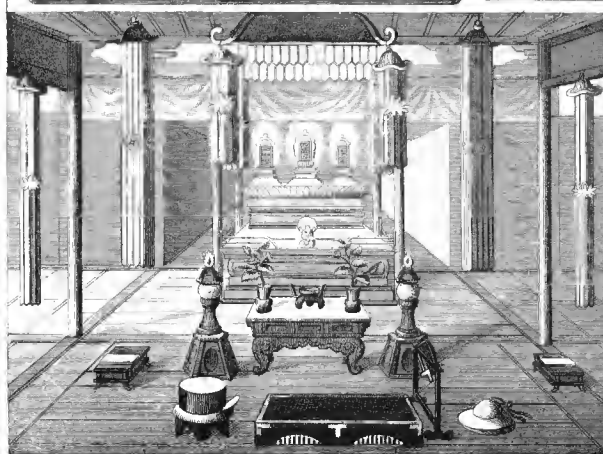
門外漢不識乃福無



器物地福亦如神



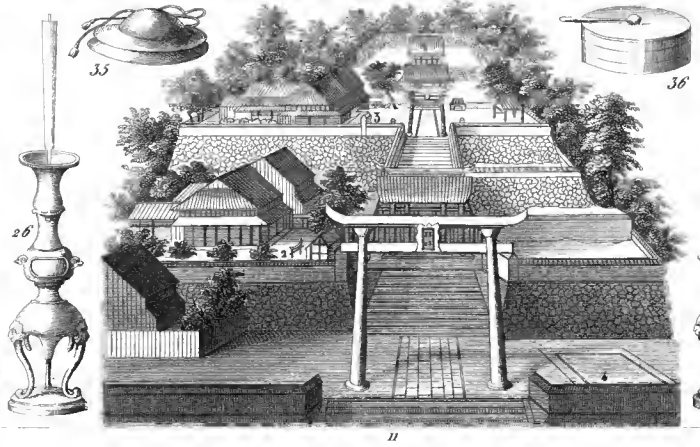
弘覺山禪師



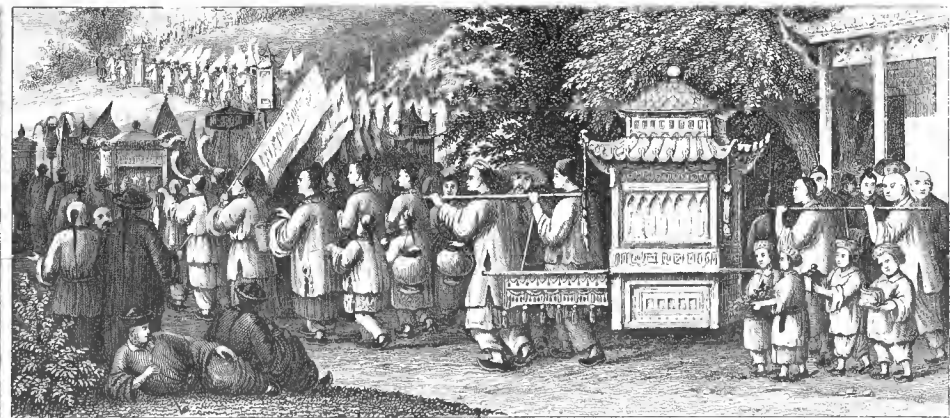


立坐十ノ品型上ノ

生坐十ノ品型上ノ 日大衆界剛多金



39 38 40 26 35 36 27 41 42 37



石と文と兒と



輪と金と字と一と



20a



10



23



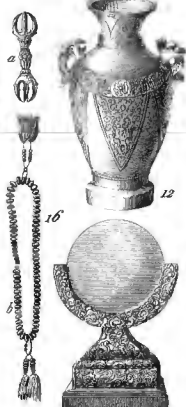
20b



尊と達と苦と初と与と刺と
者と磨と提と和と土と



19



16

14



8

5

4

6

7



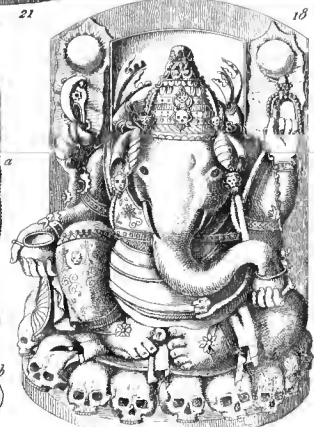
13



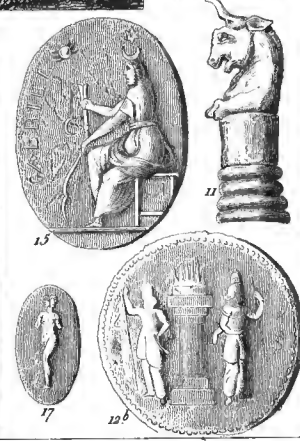
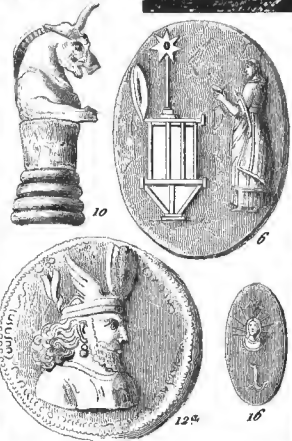
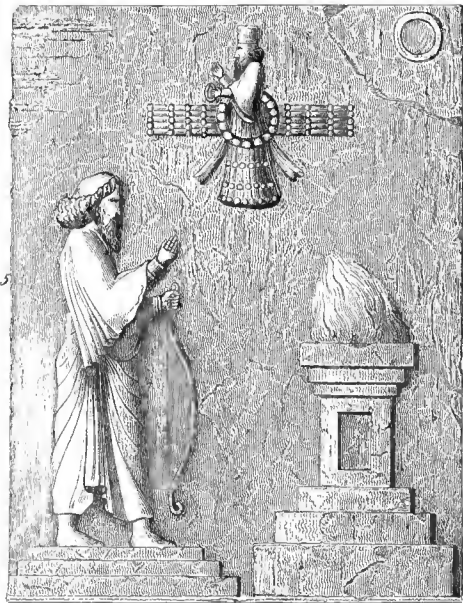
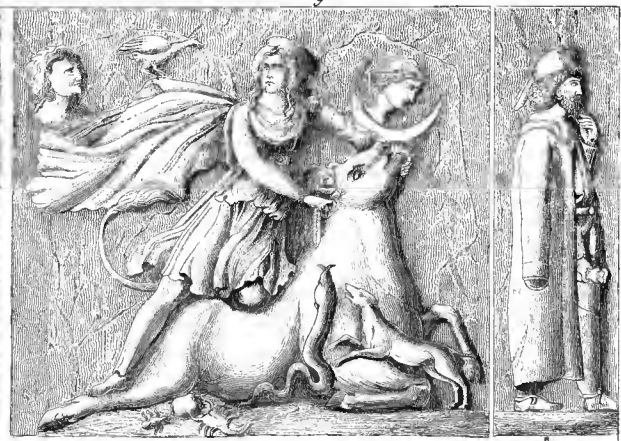
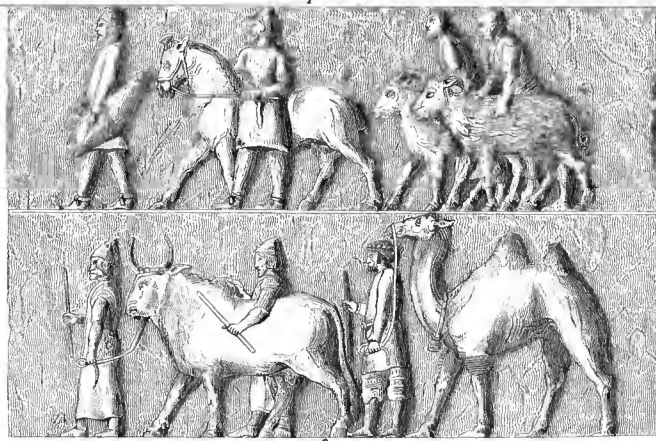
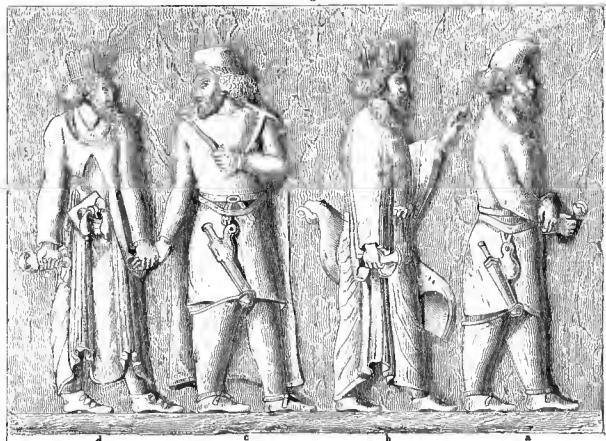
12

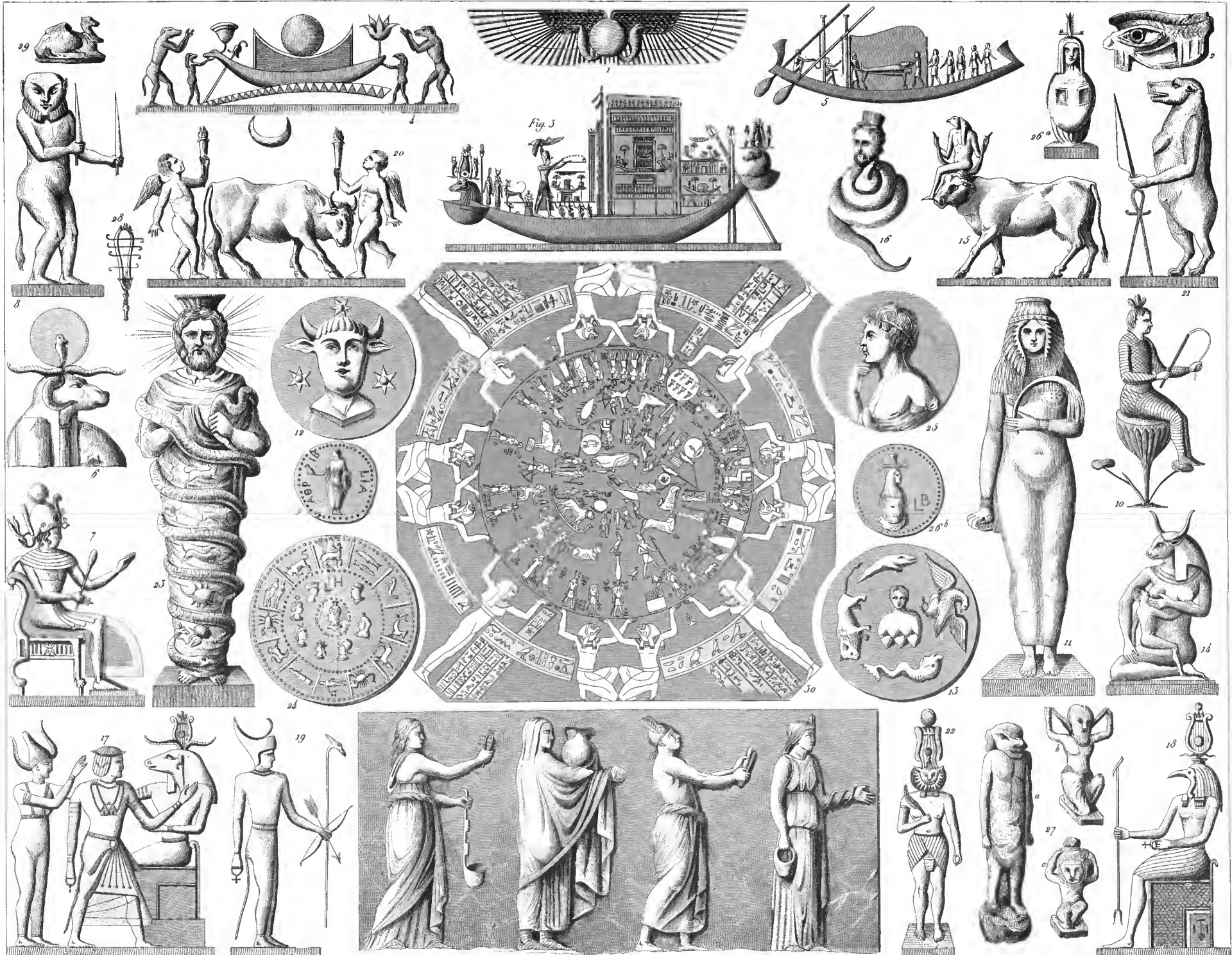


17



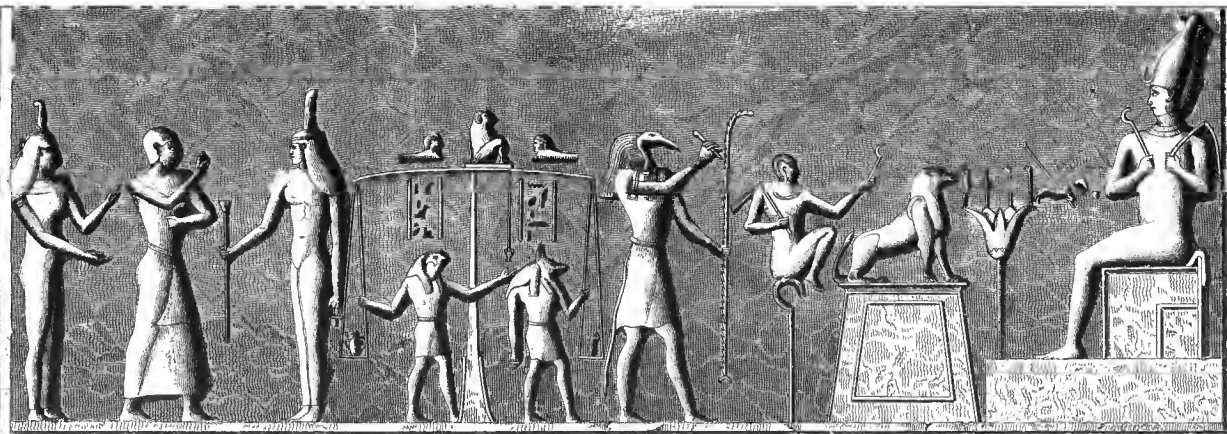
18







6



10



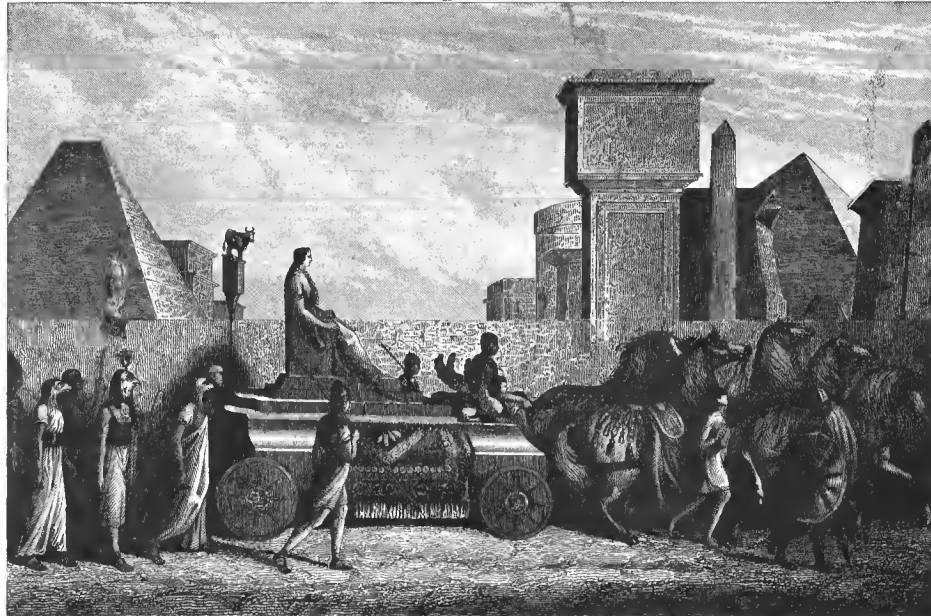
7



4

10

15

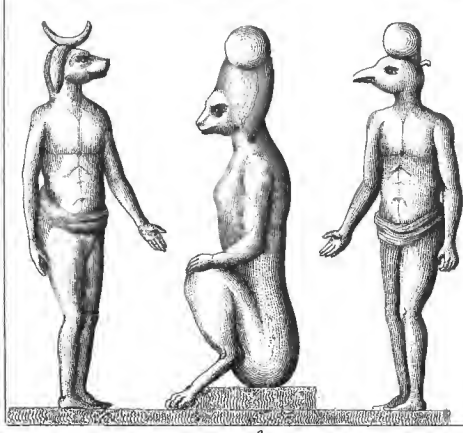


20



16

9

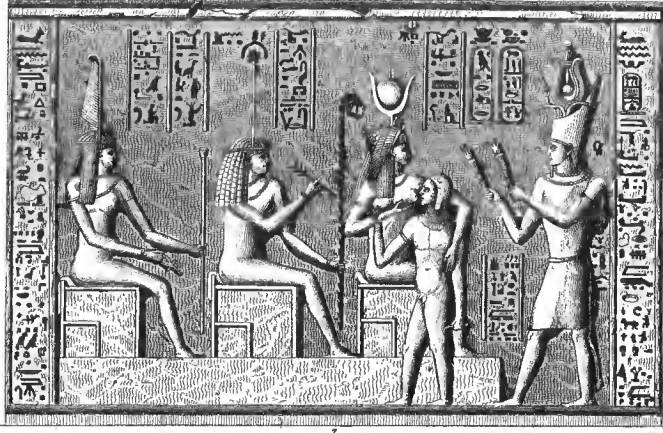


8



25

26

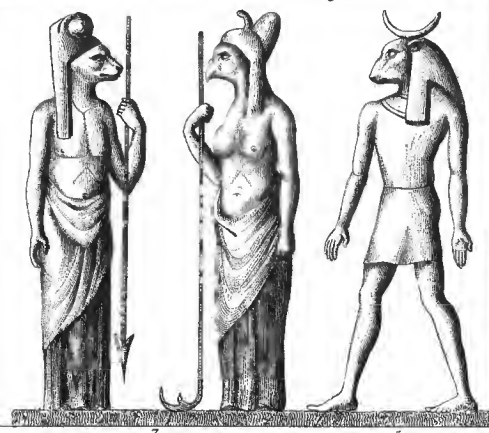


3



27

28



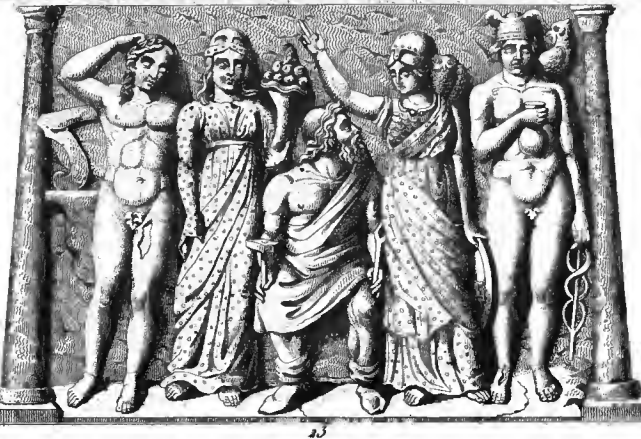
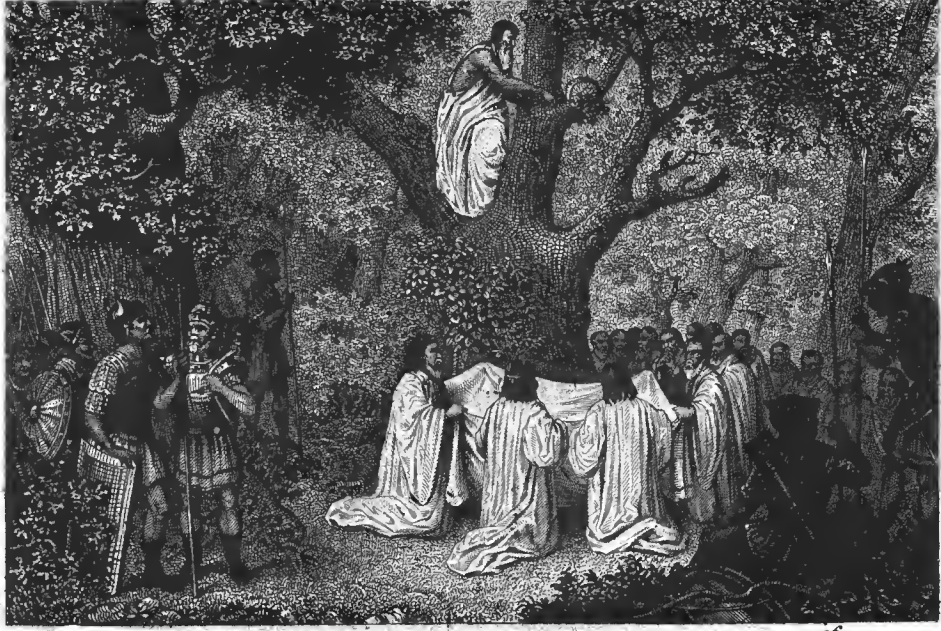
7

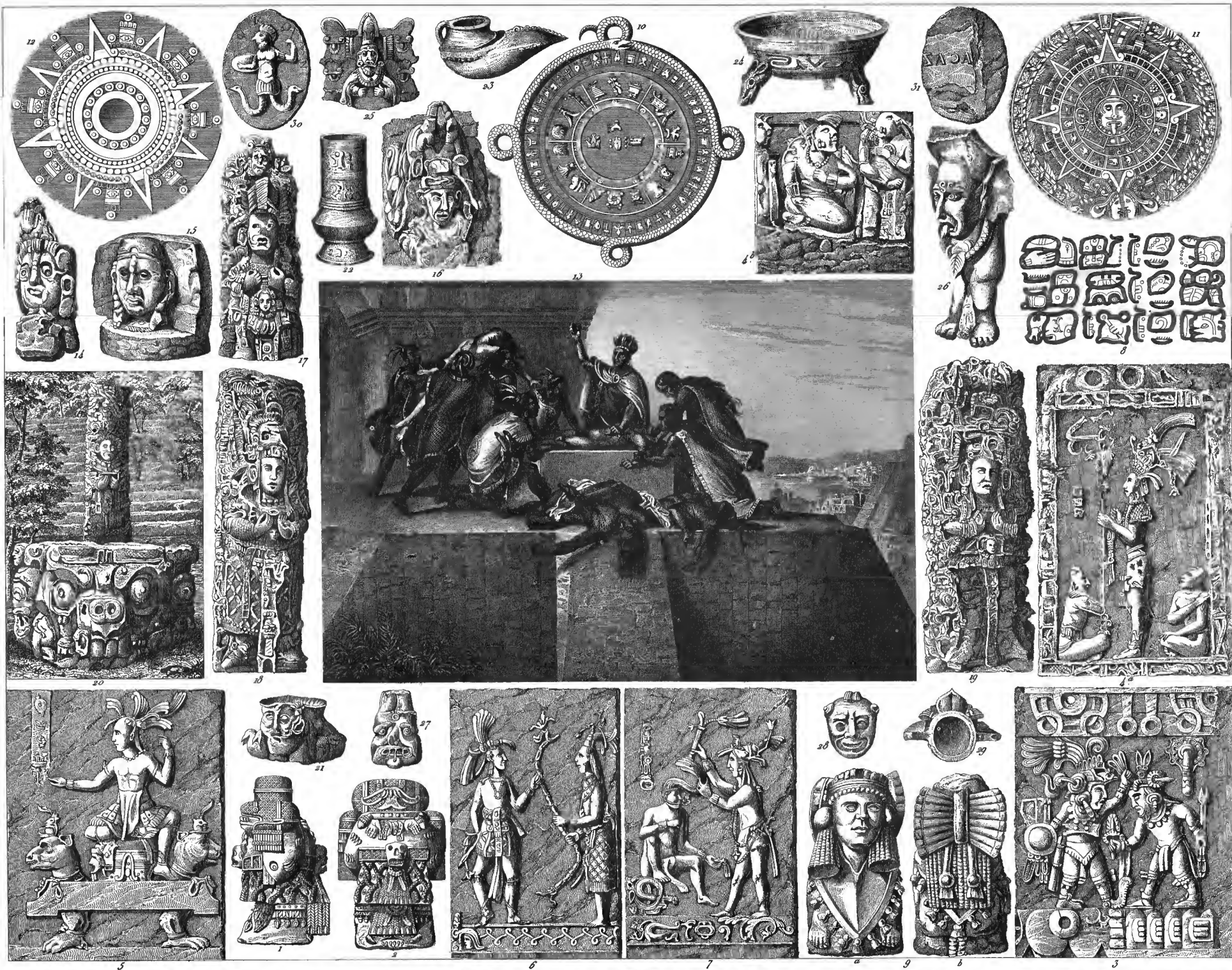
5

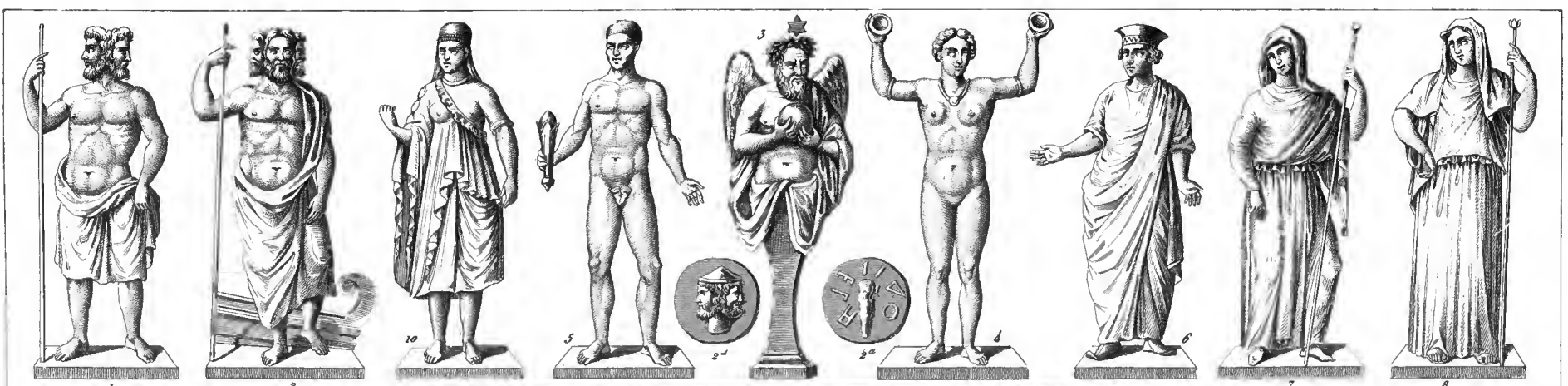


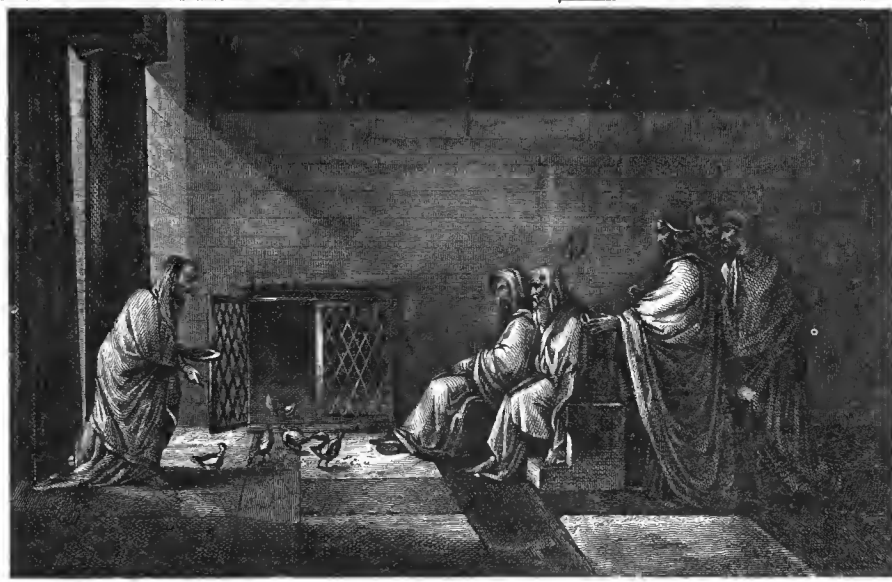
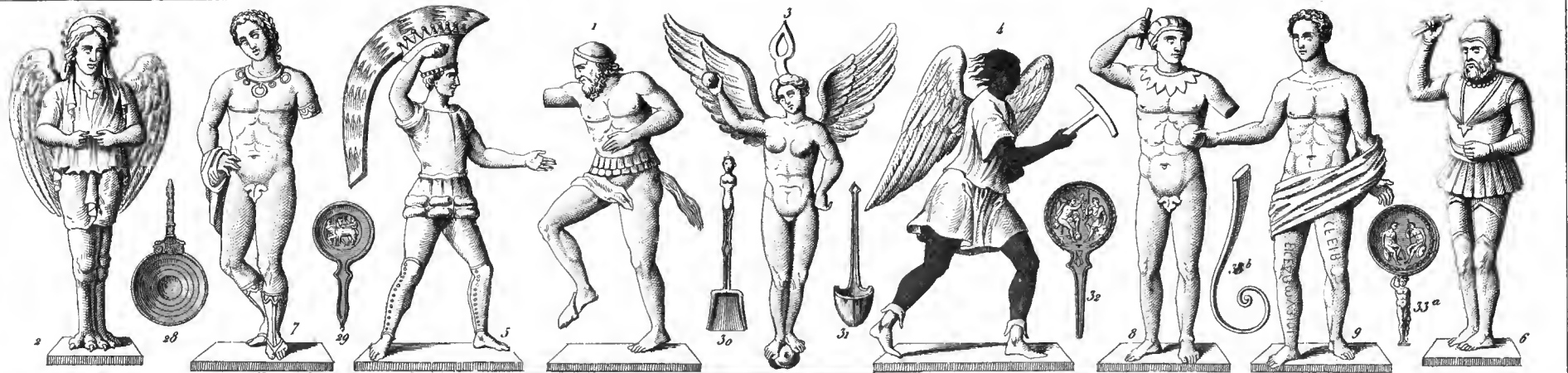


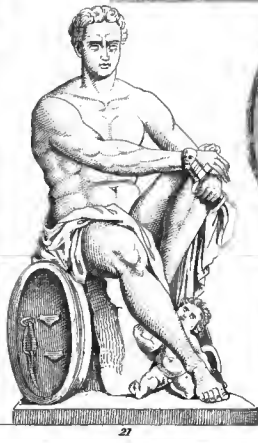
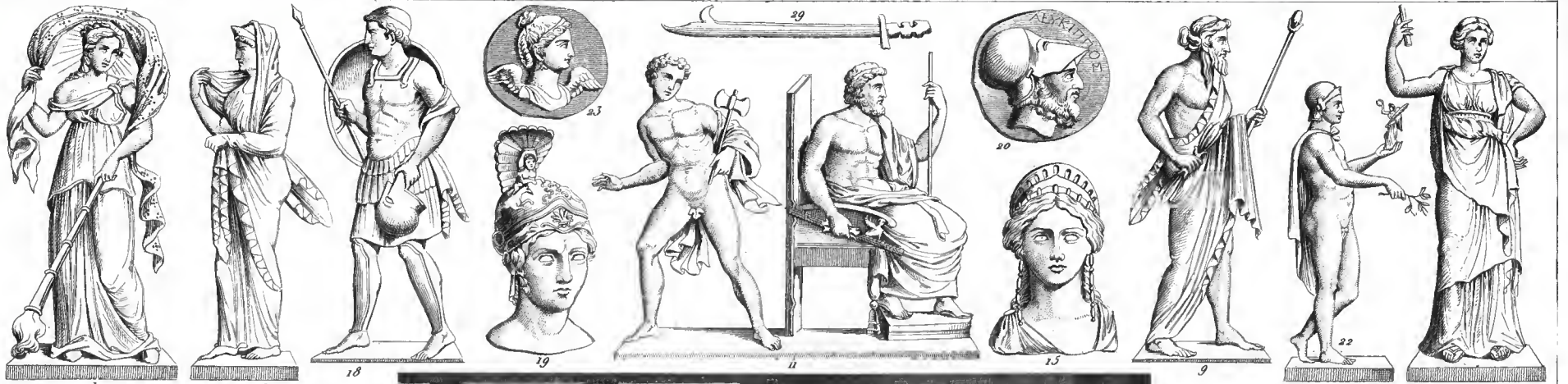


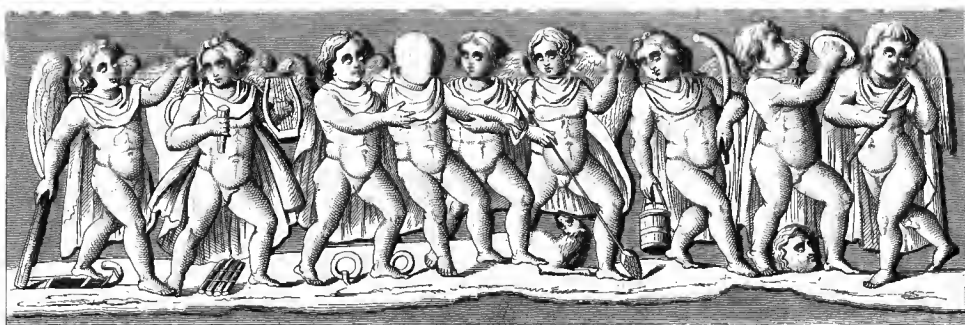
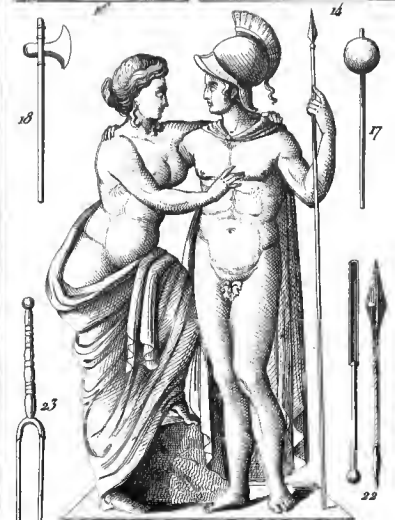
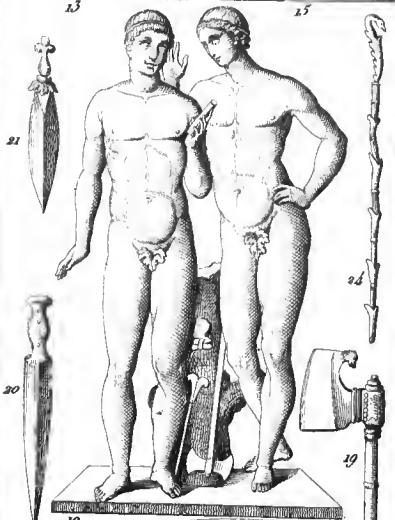


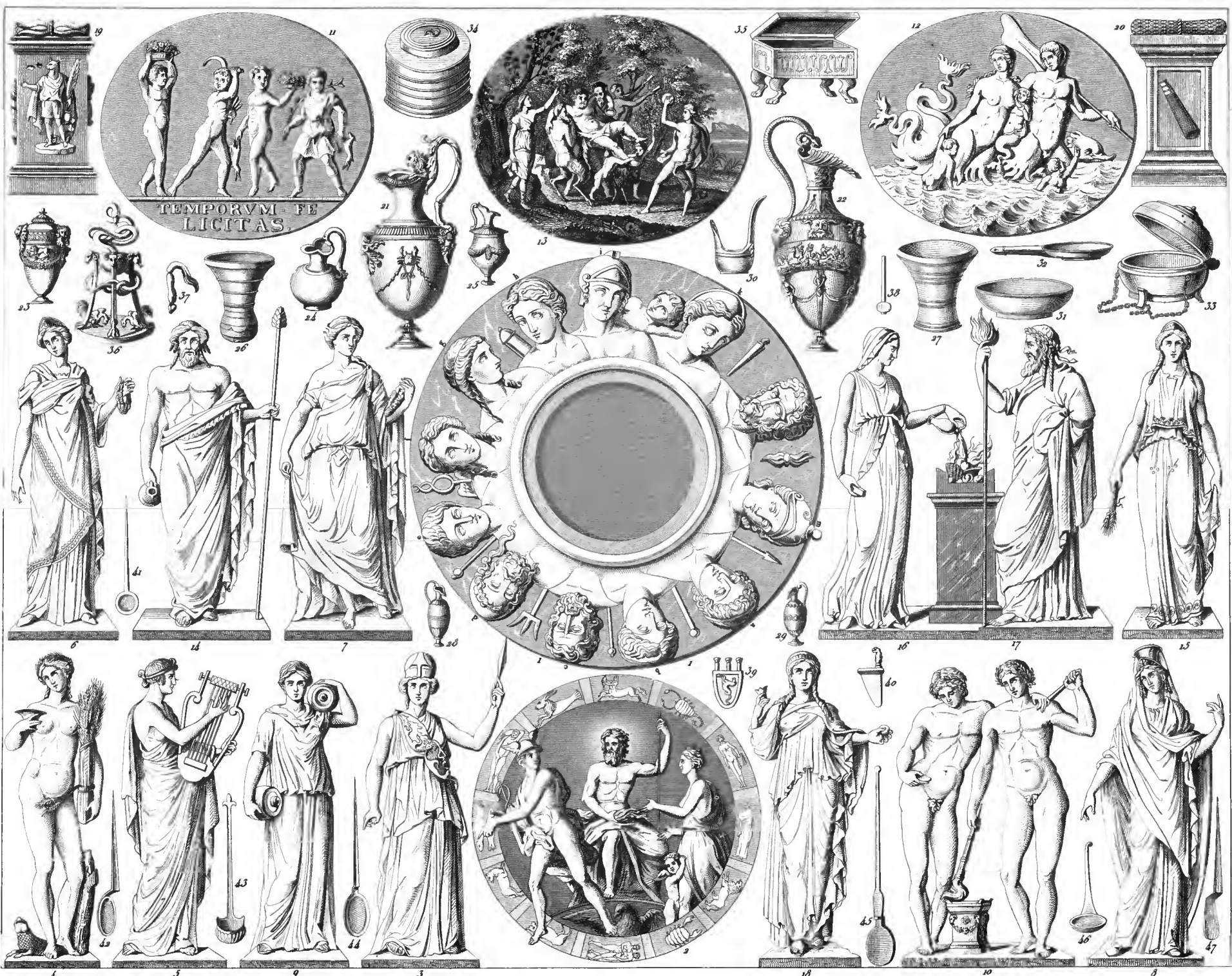




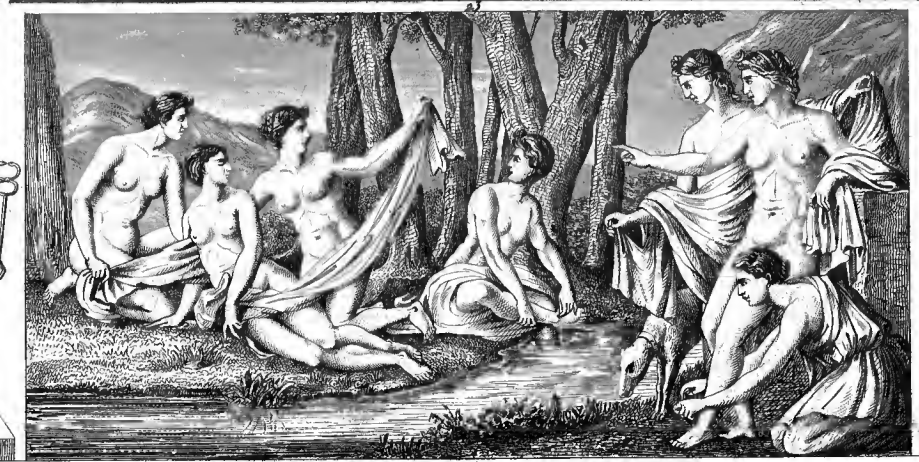
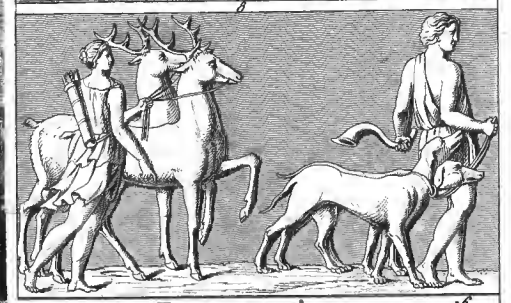
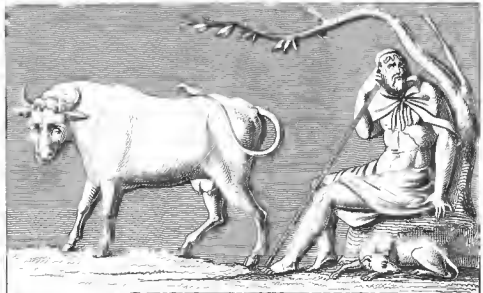
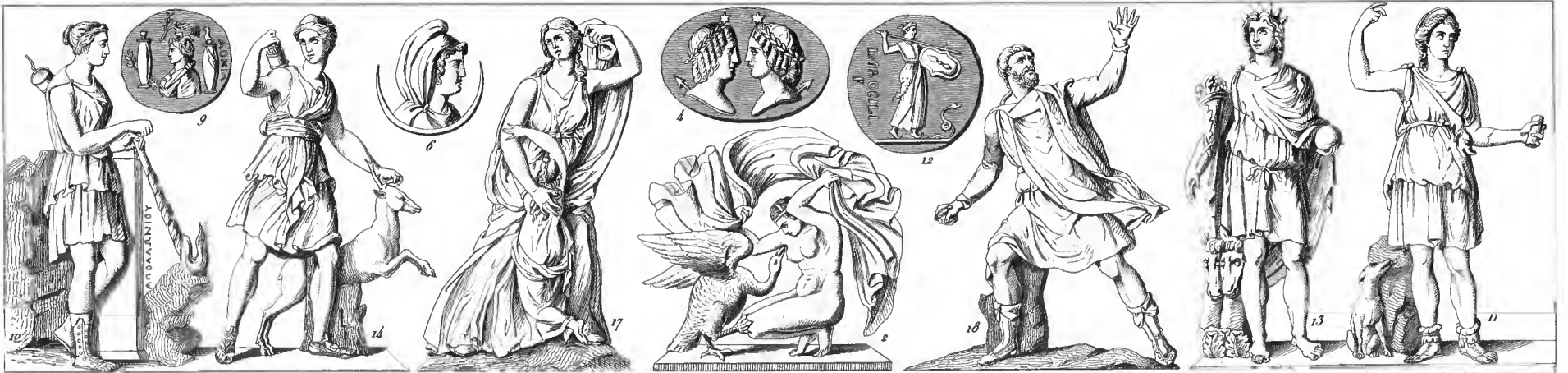


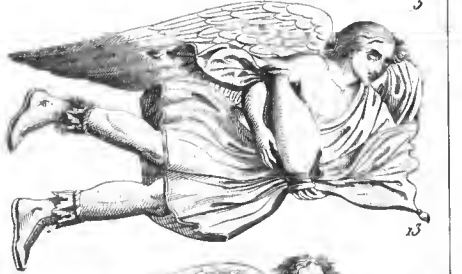
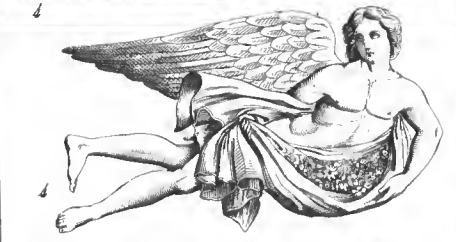
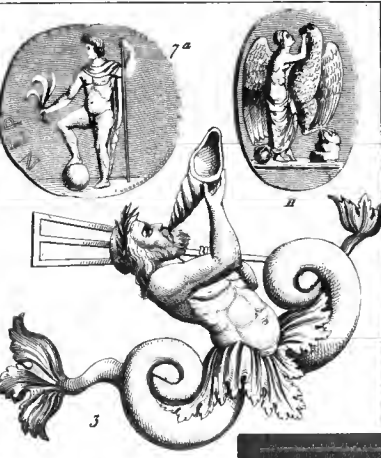


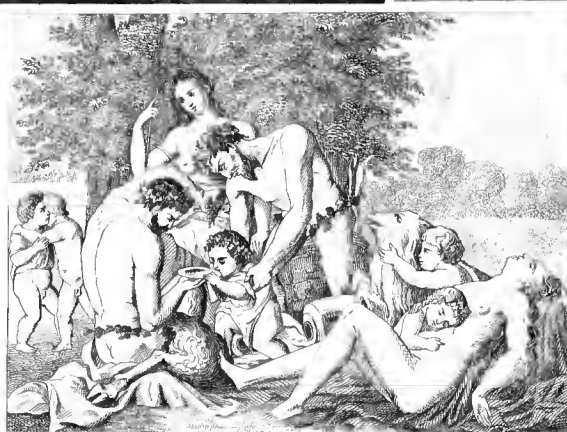


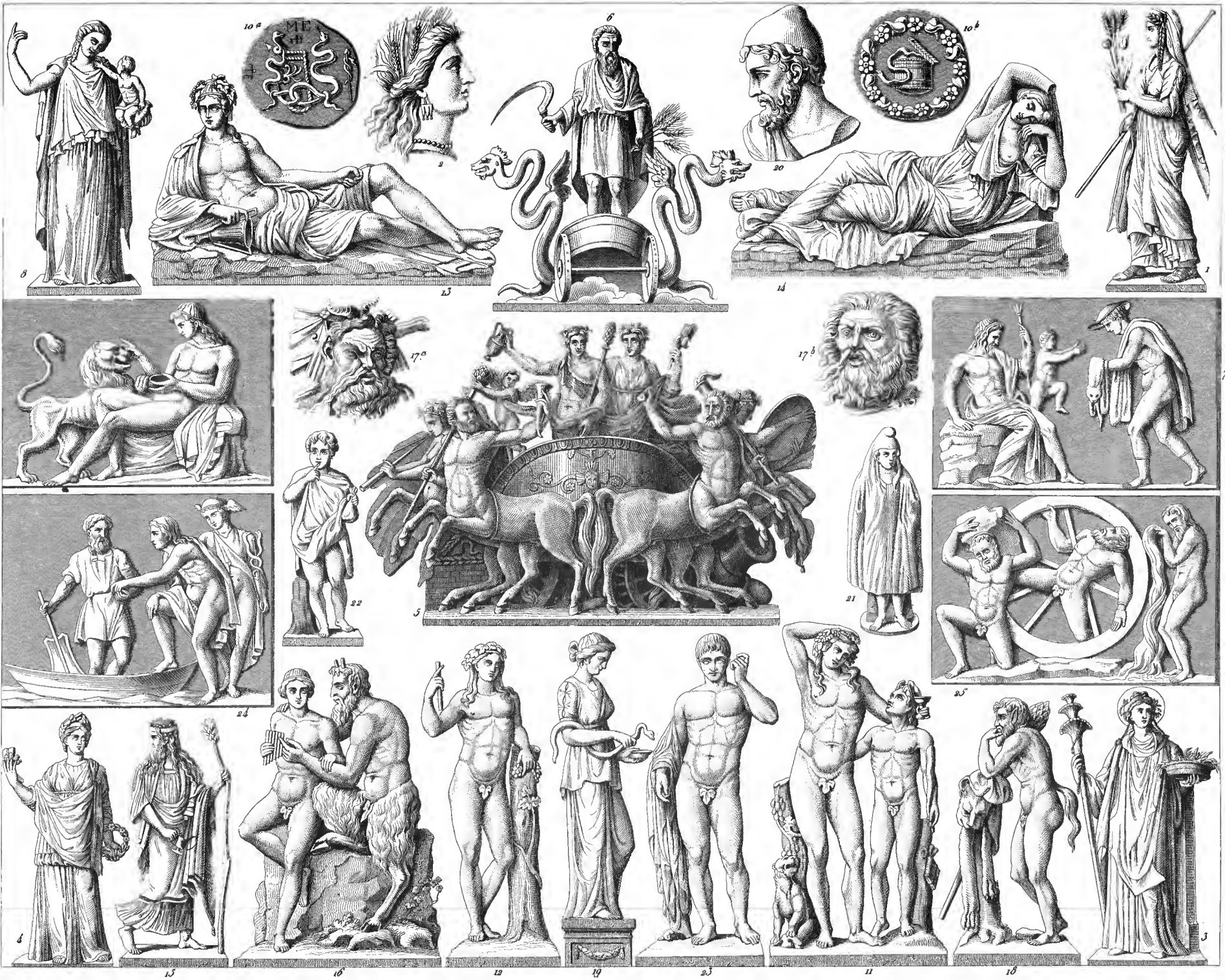


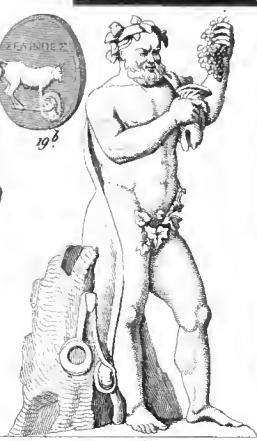
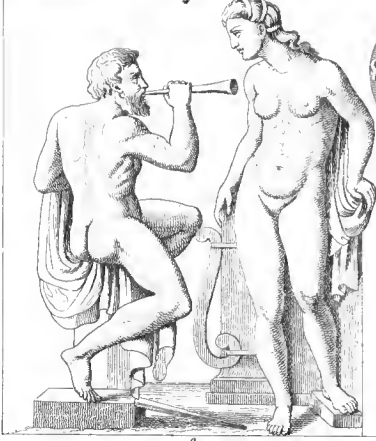
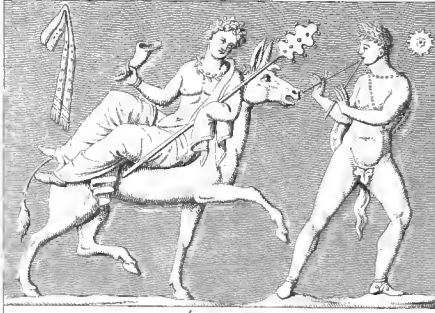
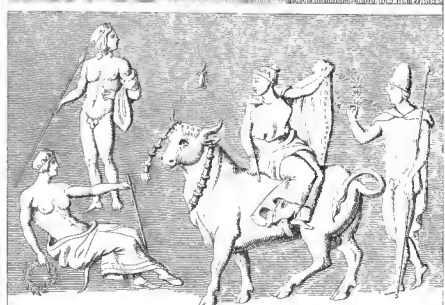
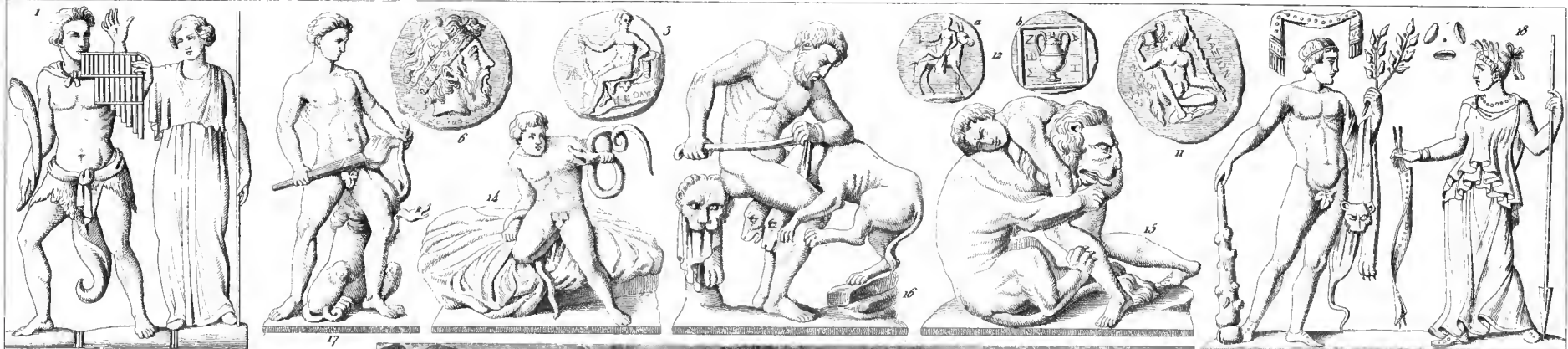
TEMPORVM FELICITAS



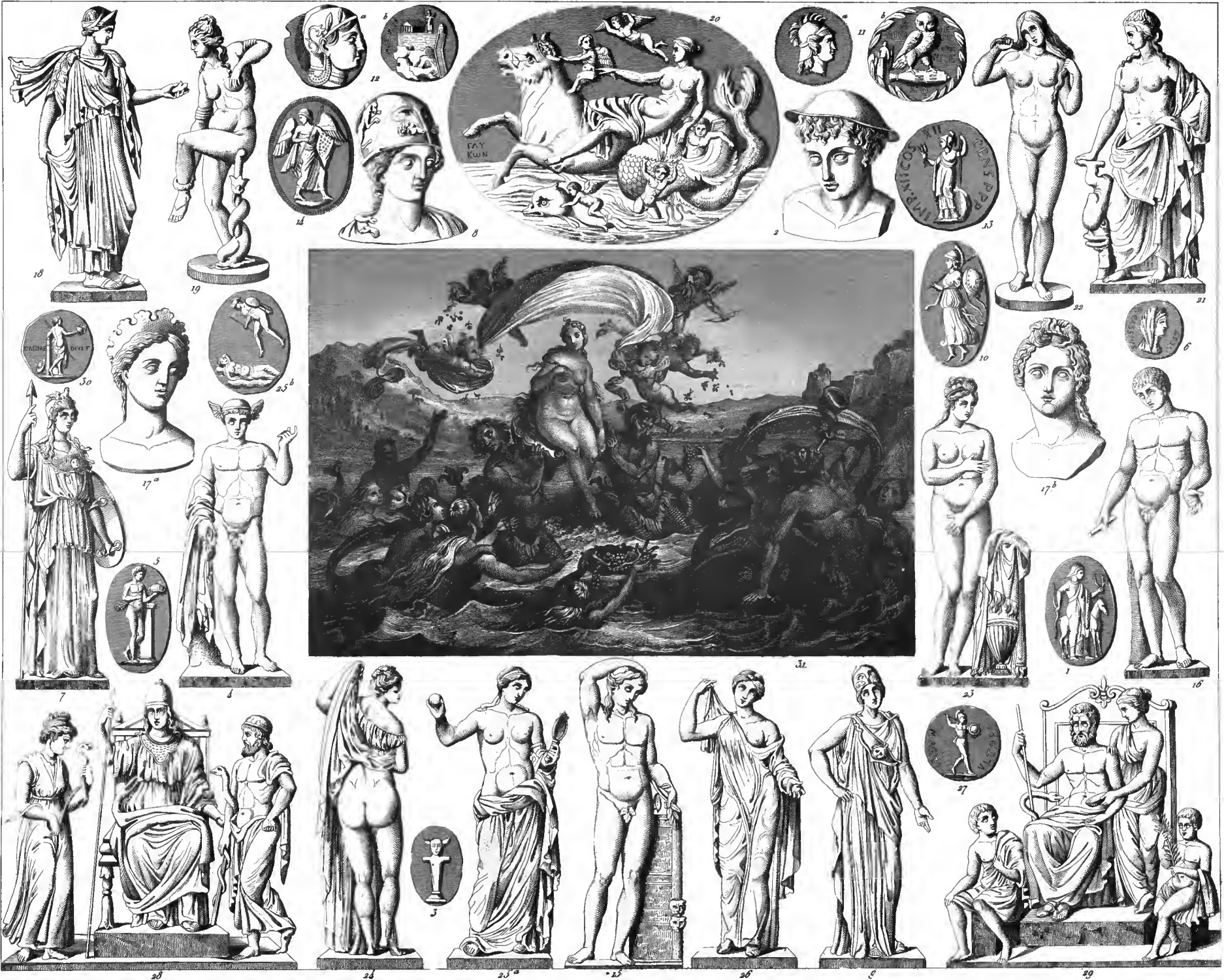


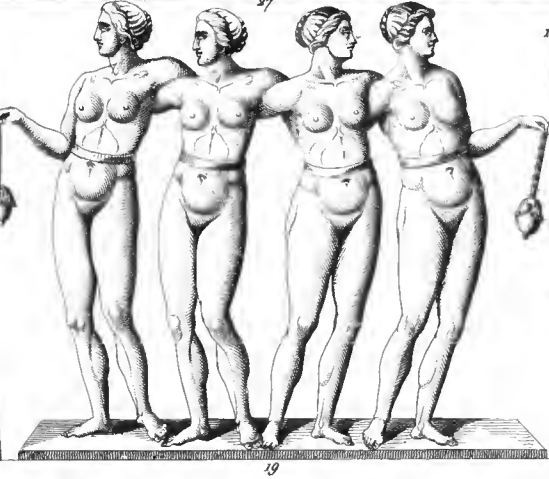
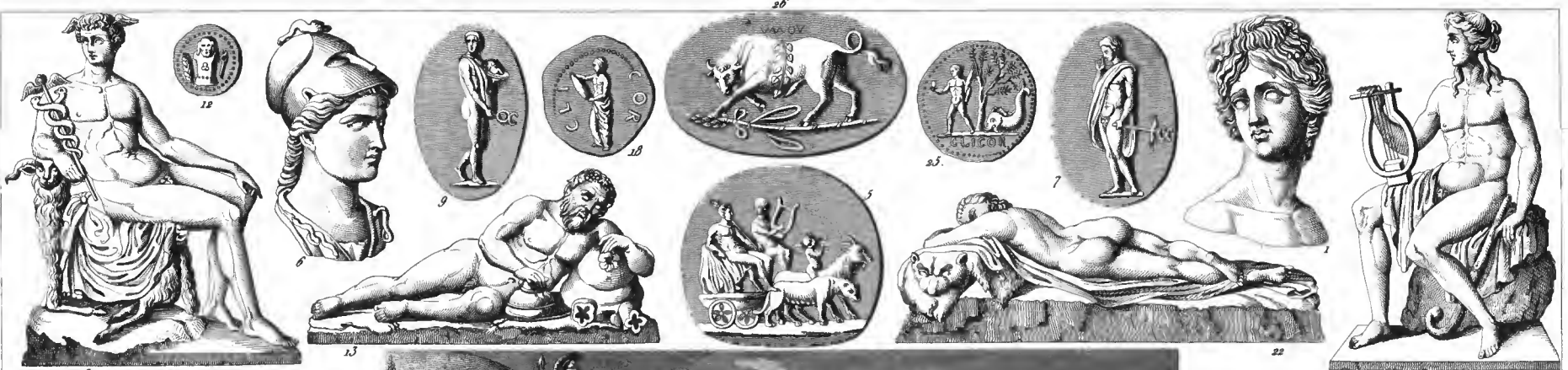


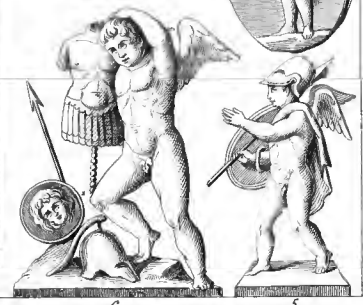
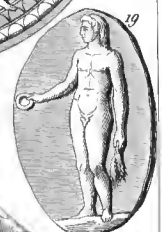




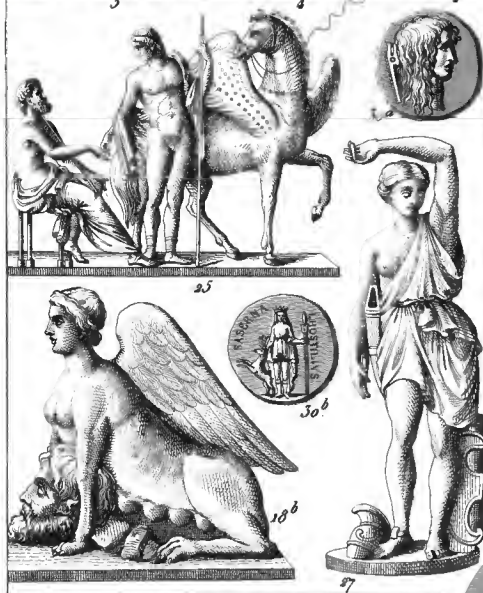
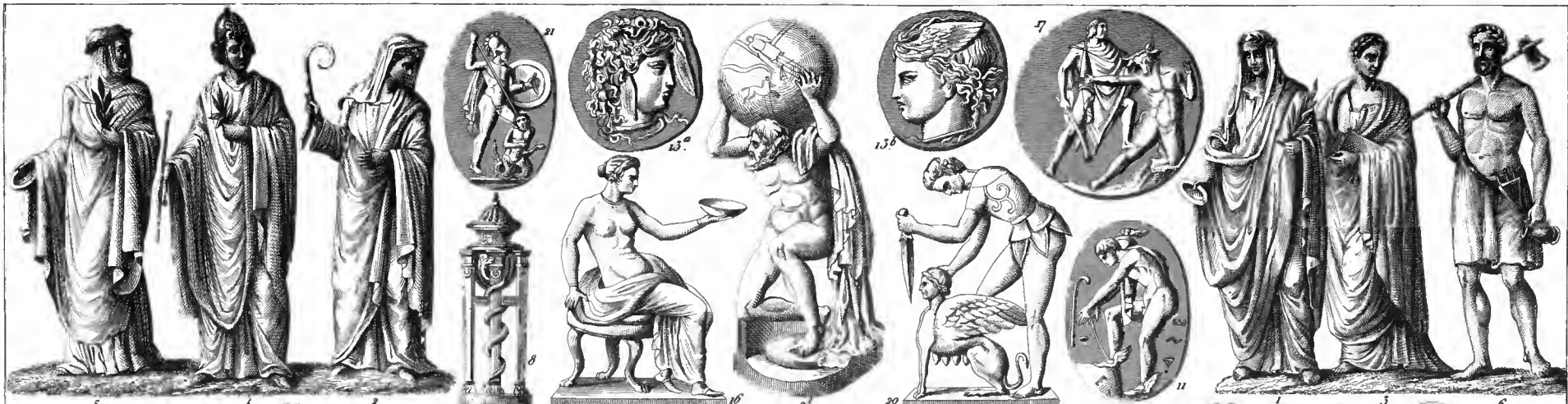


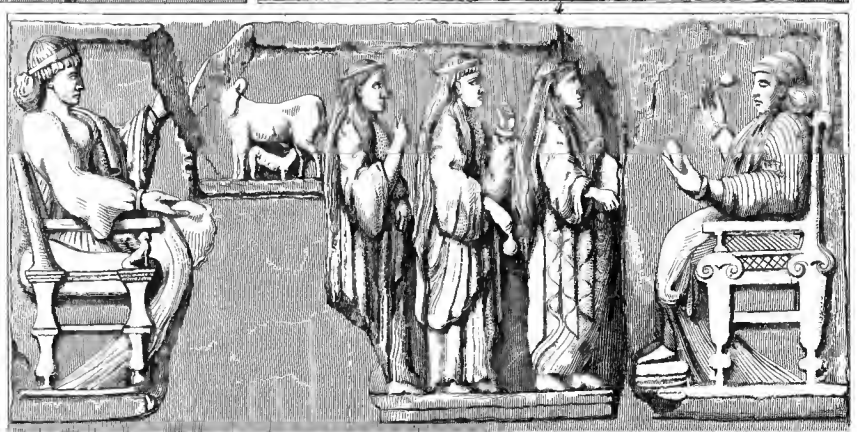
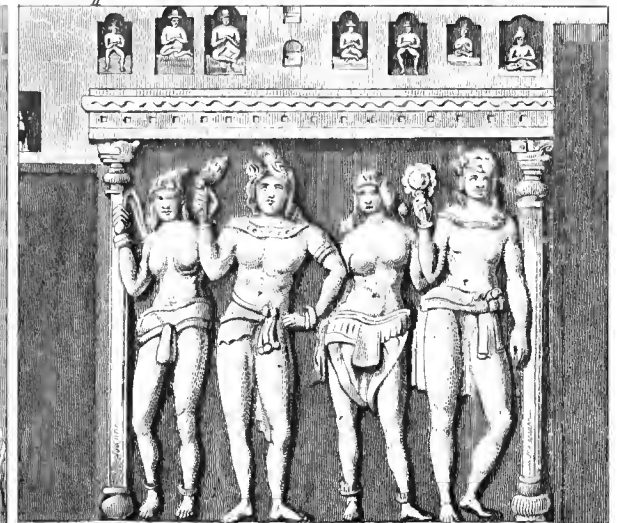
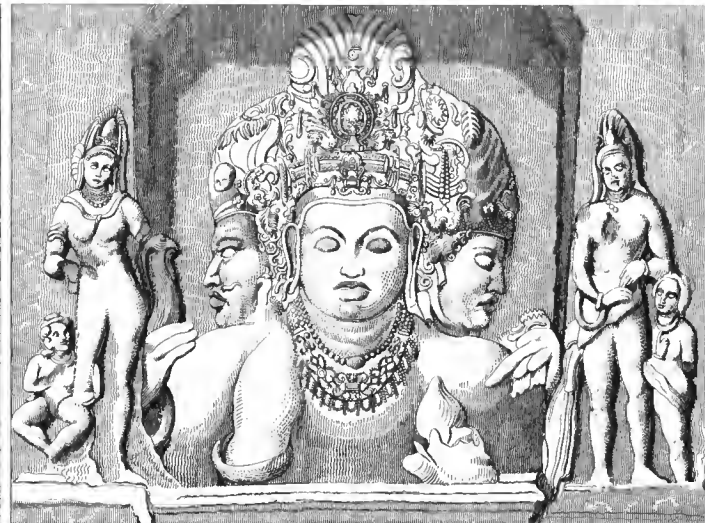






5





15

6

14



ICONOGRAPHIC
E N C Y C L O P Æ D I A .

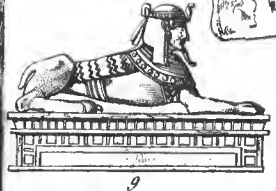
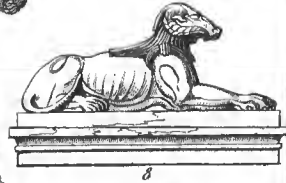
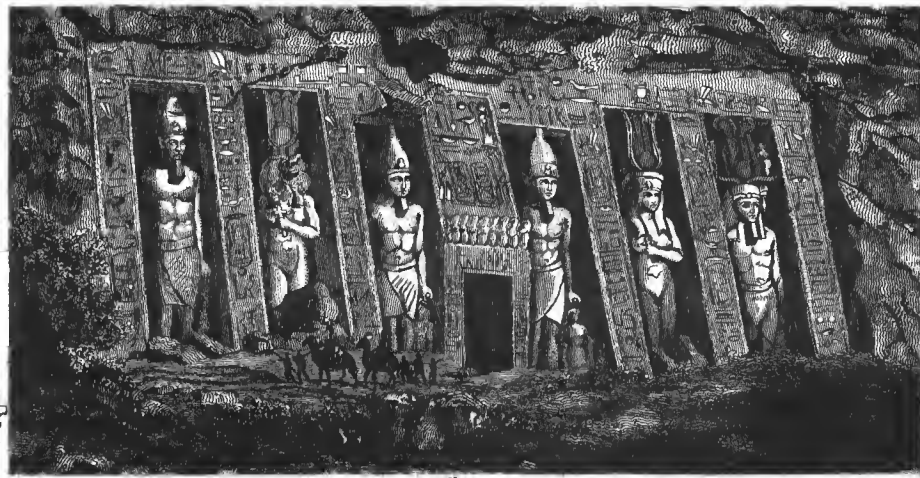
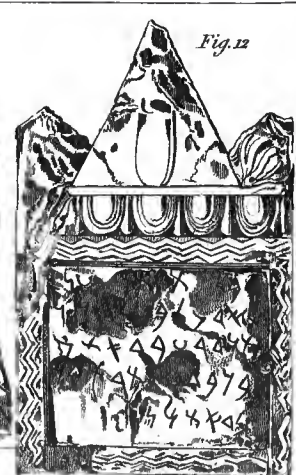
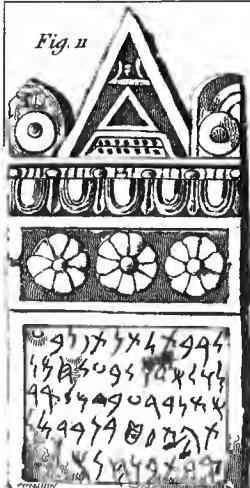
DIVISION IX.

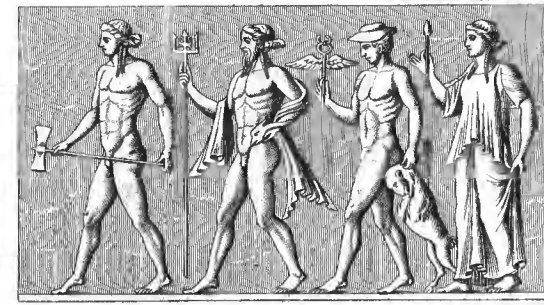
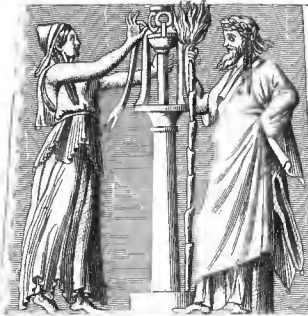
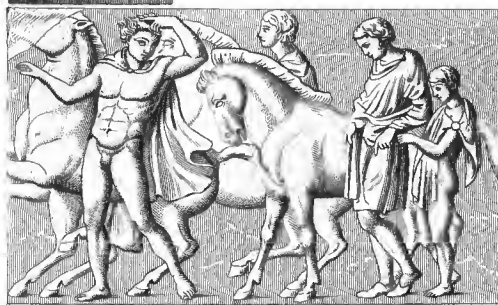
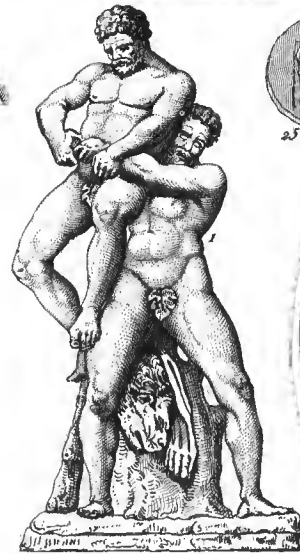
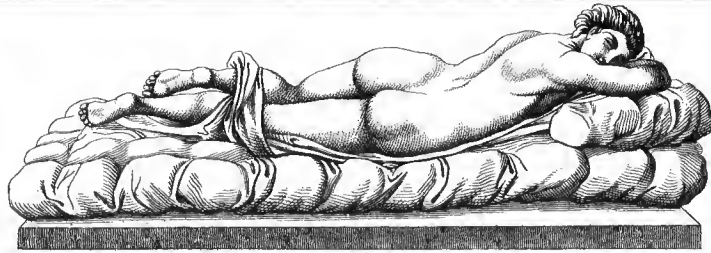
THE FINE ARTS.

TWENTY-SIX PLATES.

NEW YORK: 1851.
PUBLISHED BY RUDOLPH GARRIGUE,
2 BARCLAY STREET (ASTOR HOUSE).





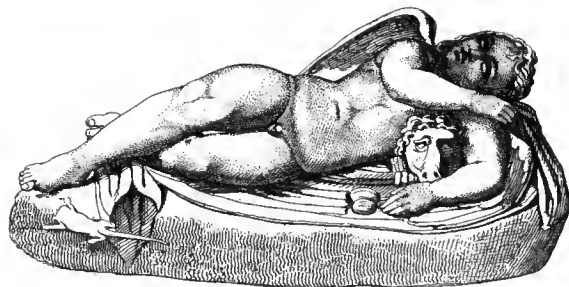




3



6



10



4



2



1



5



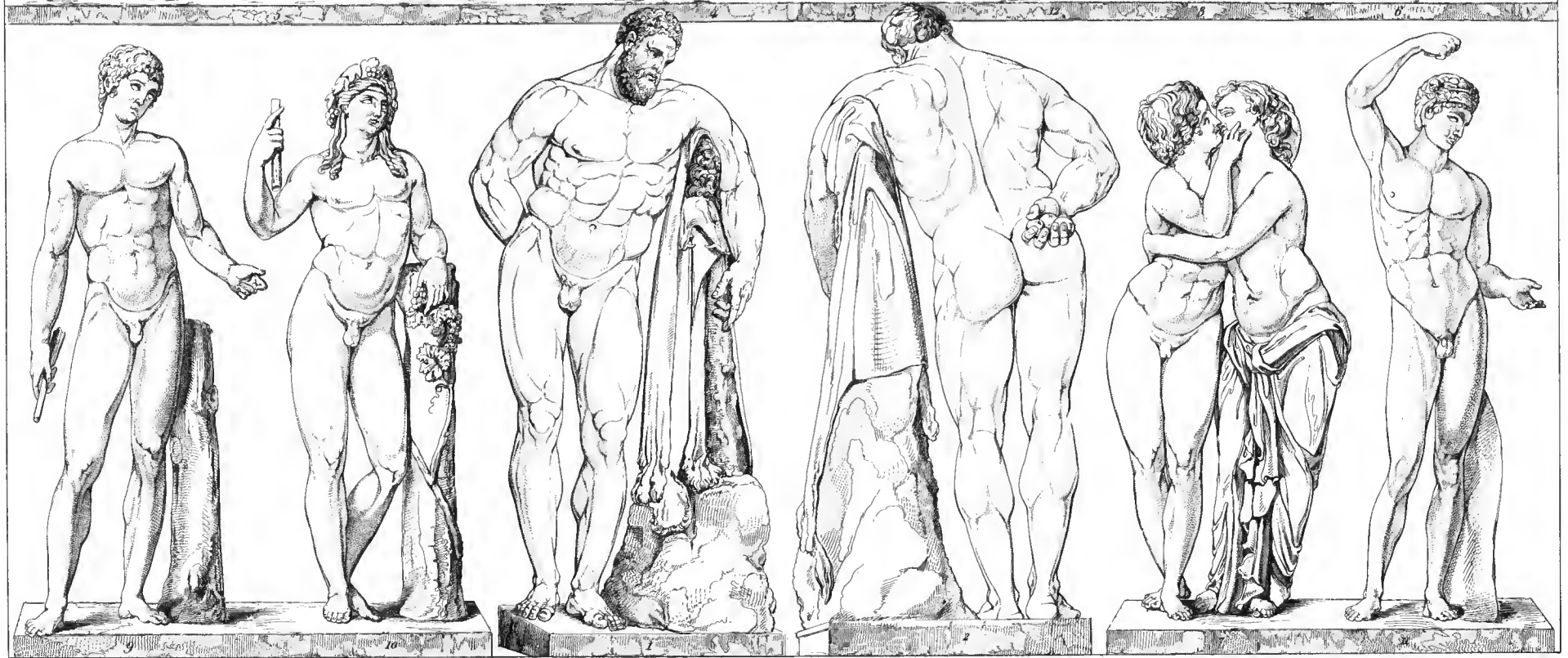
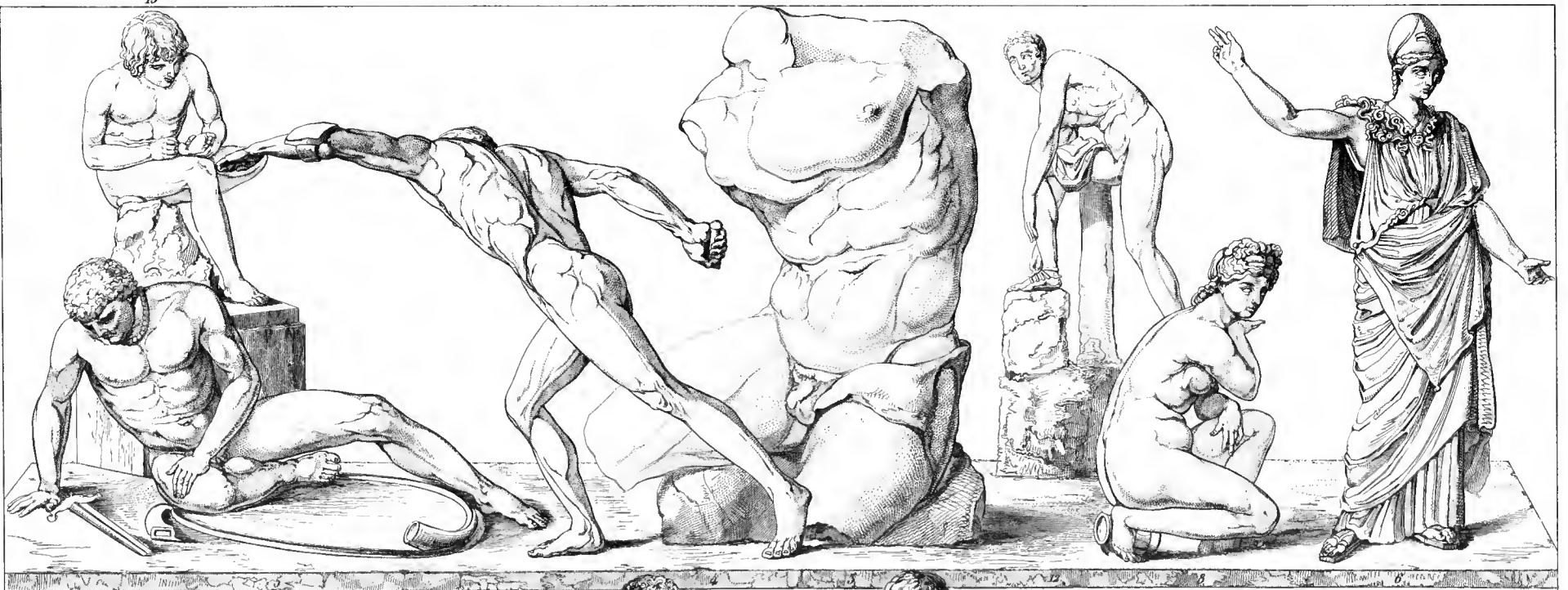
7

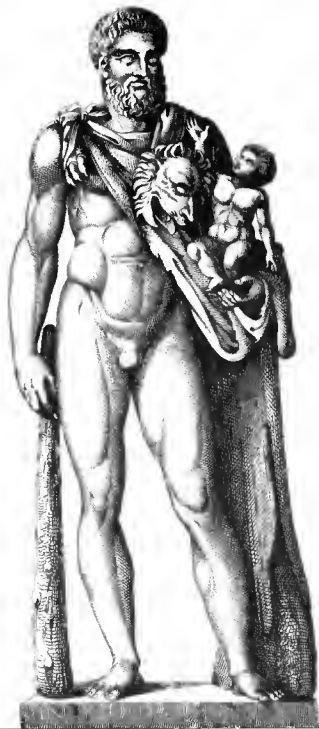


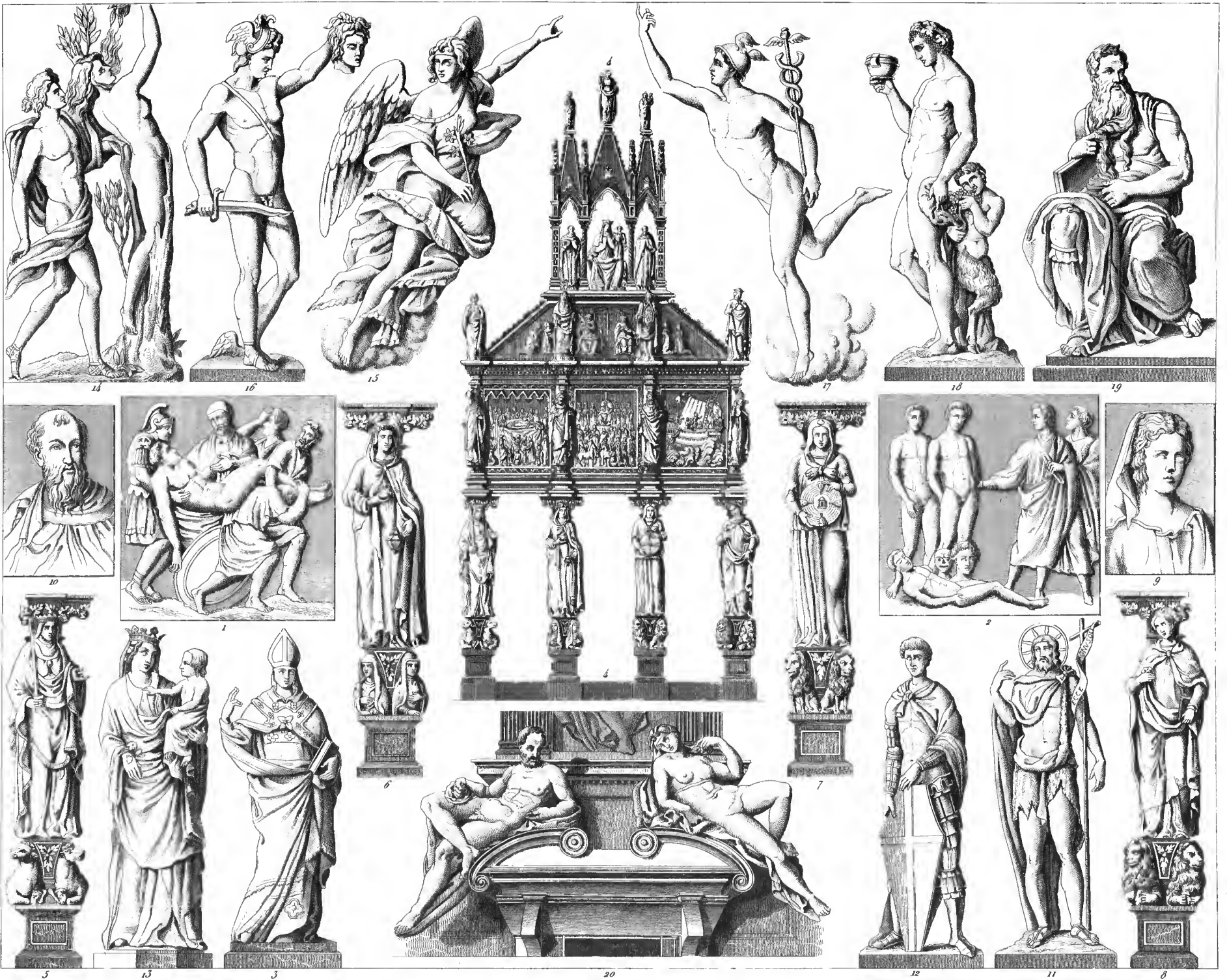
9



8









4



10



5



9



8



5



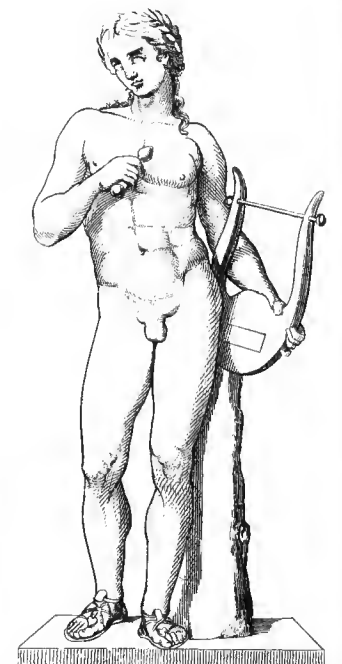
2



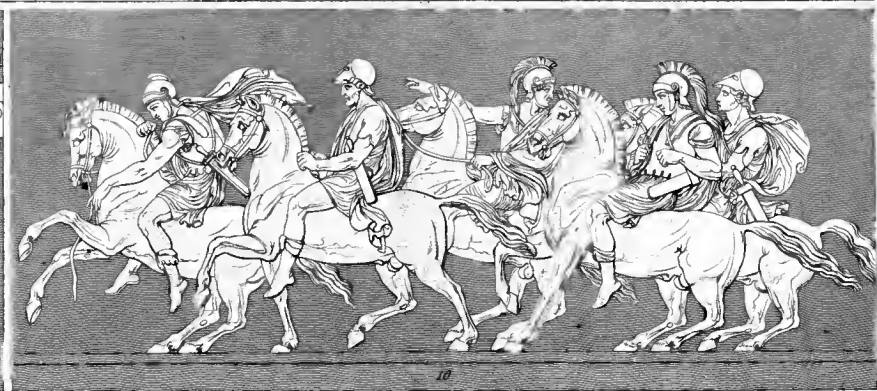
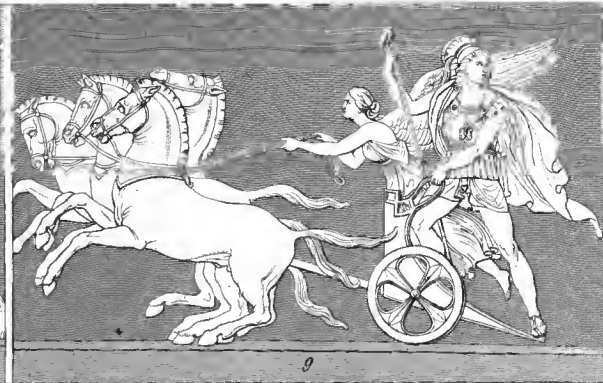
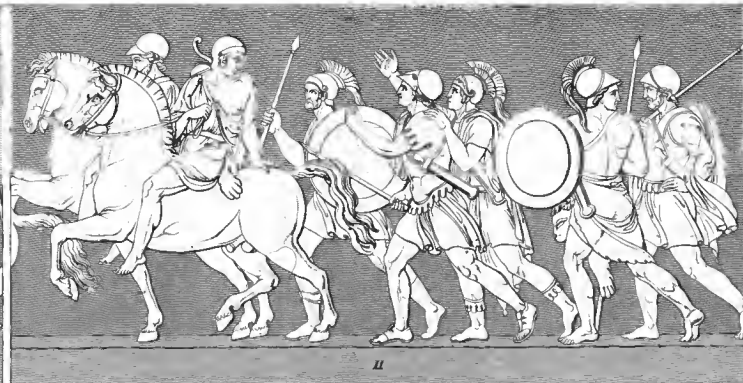
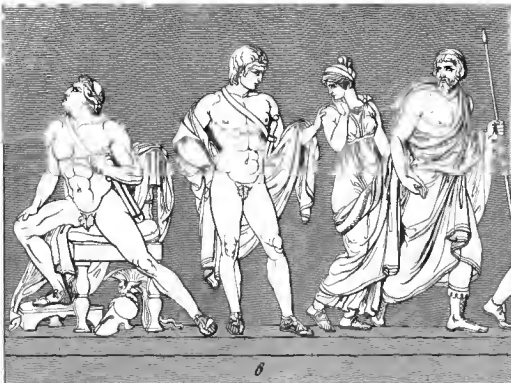
1

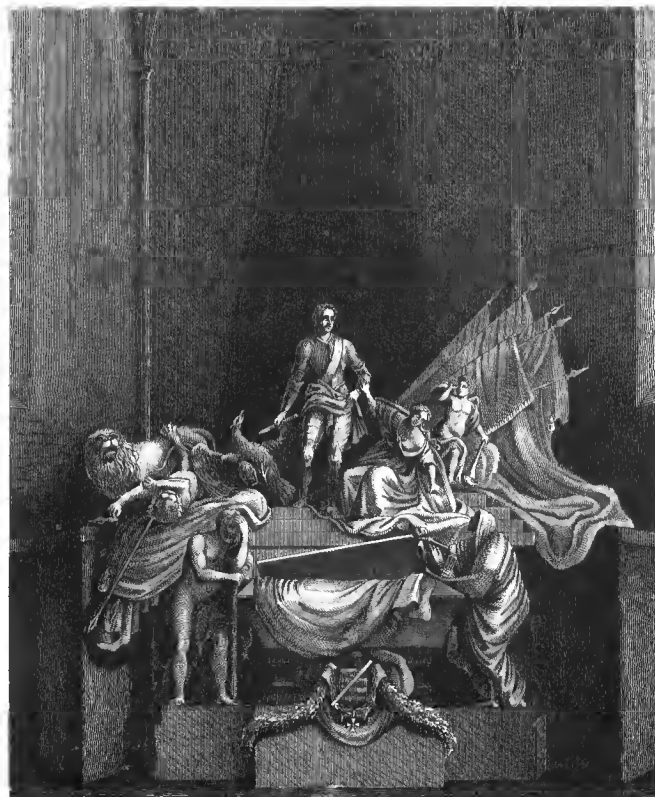


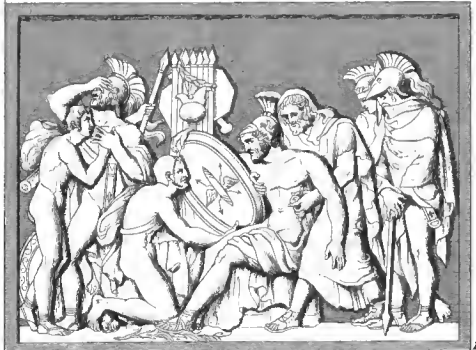
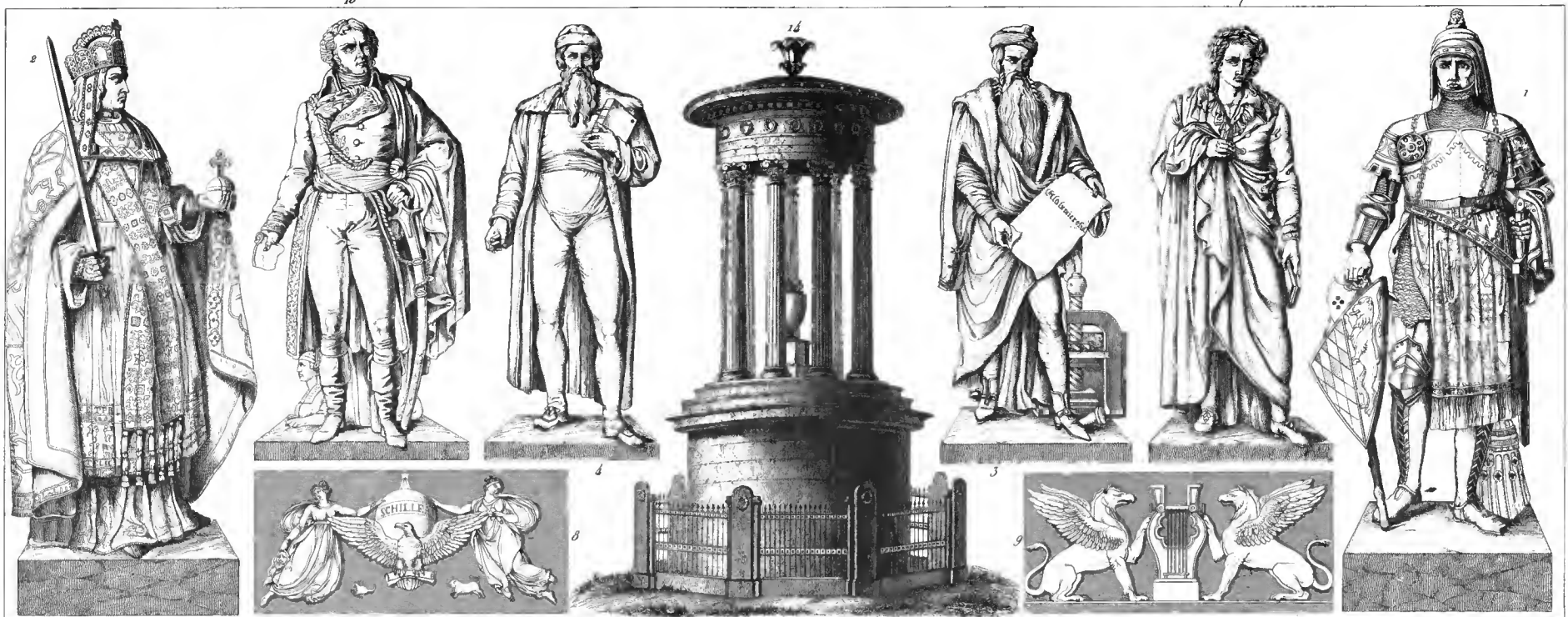
7

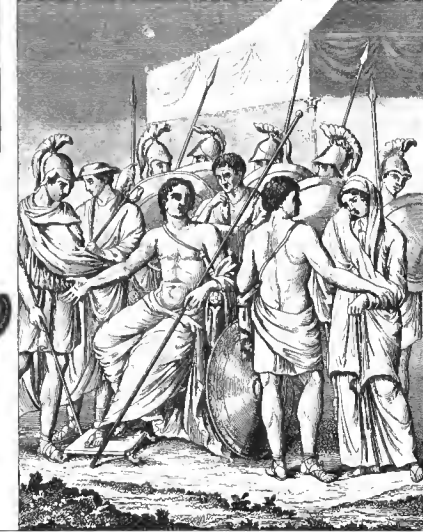
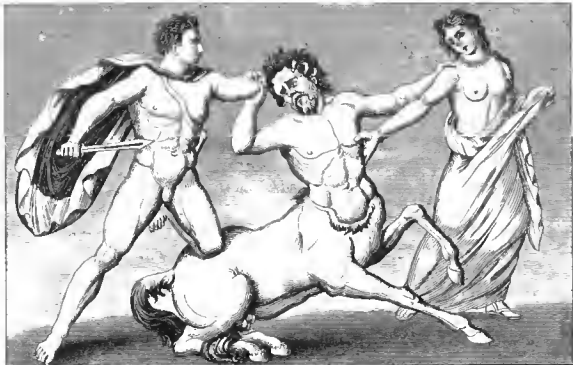
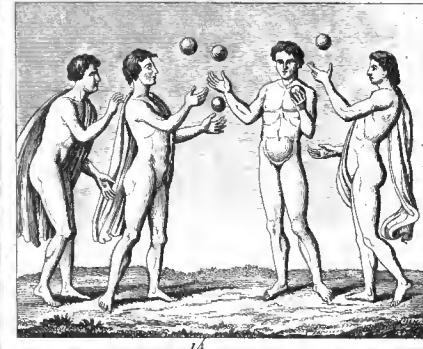


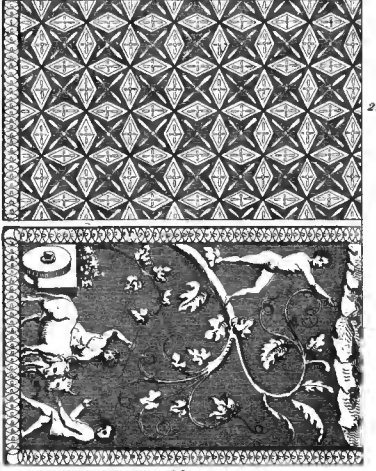
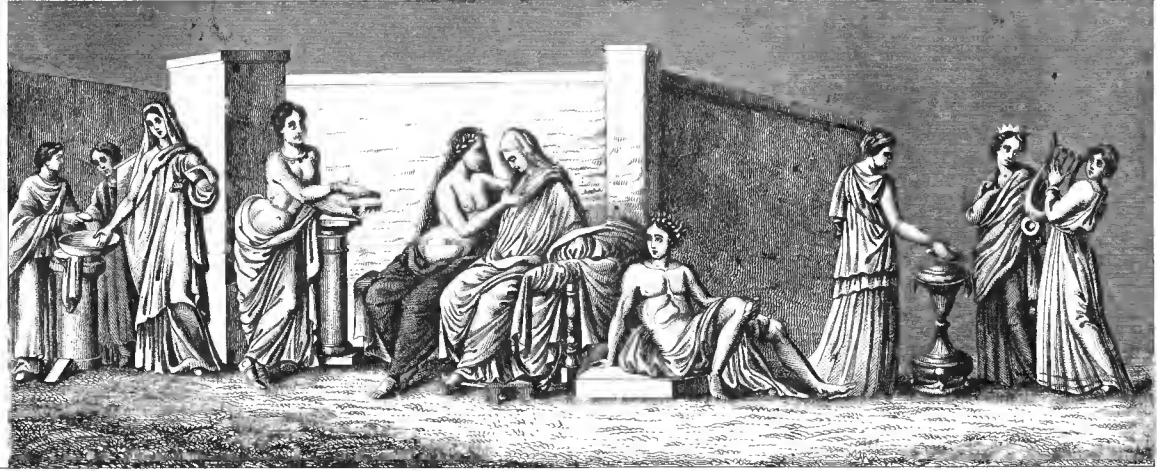
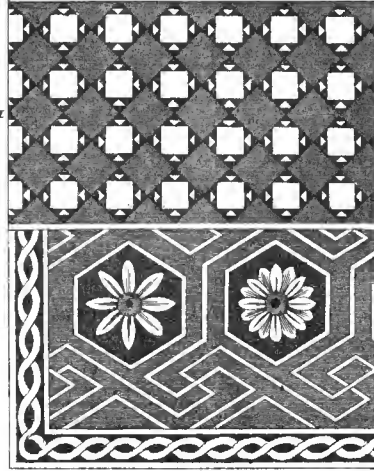
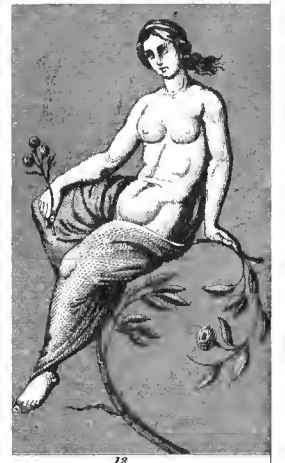
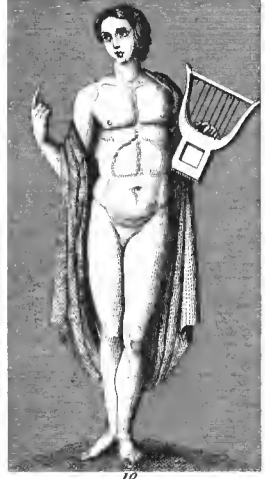
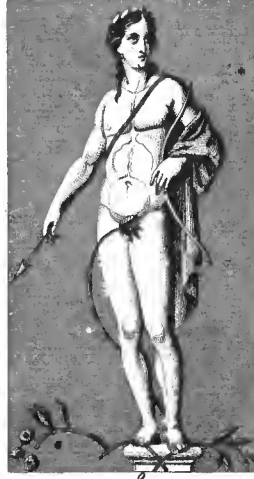
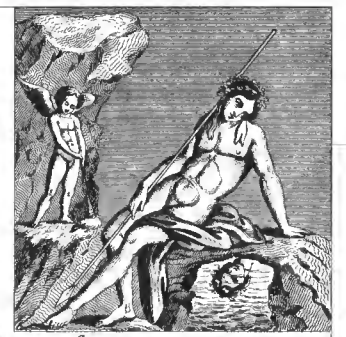
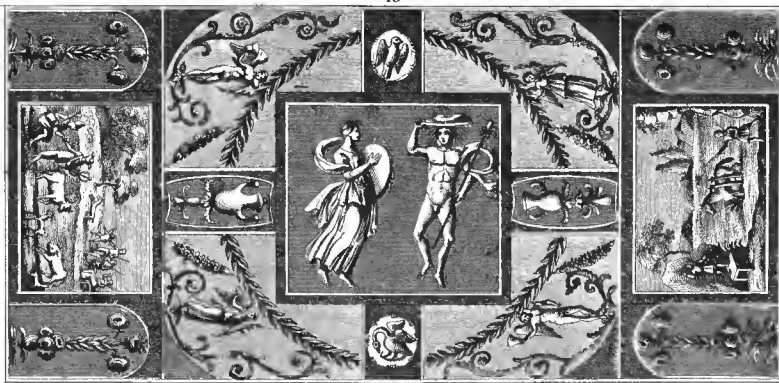
6

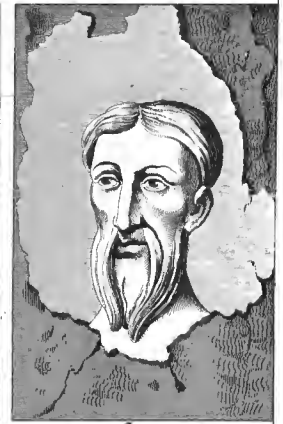
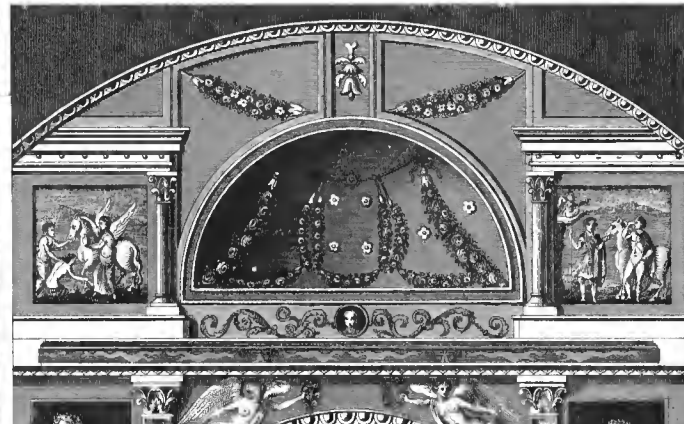
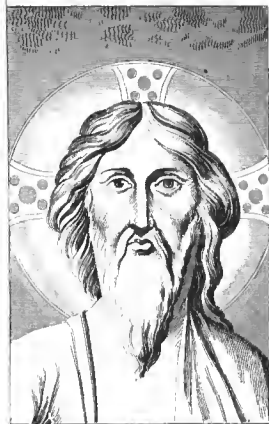
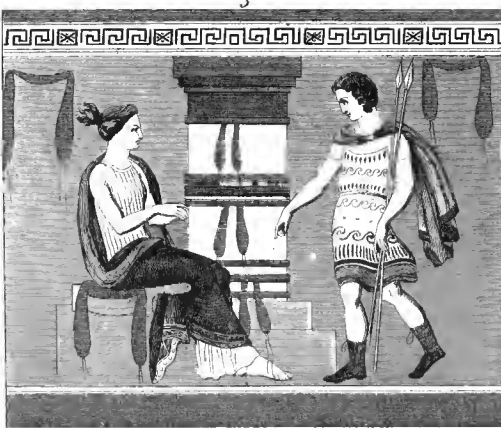




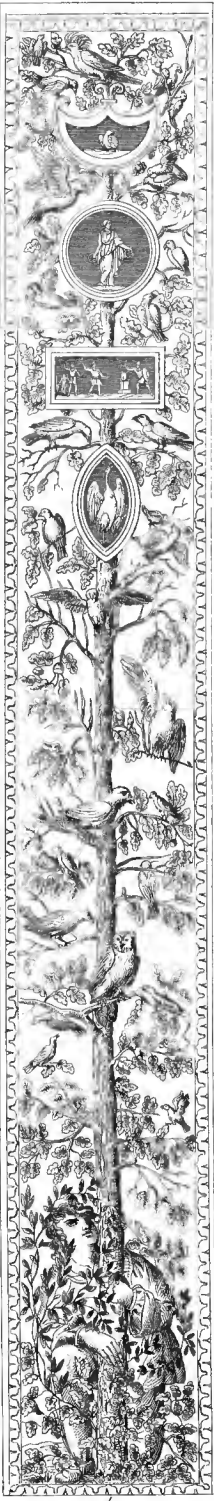
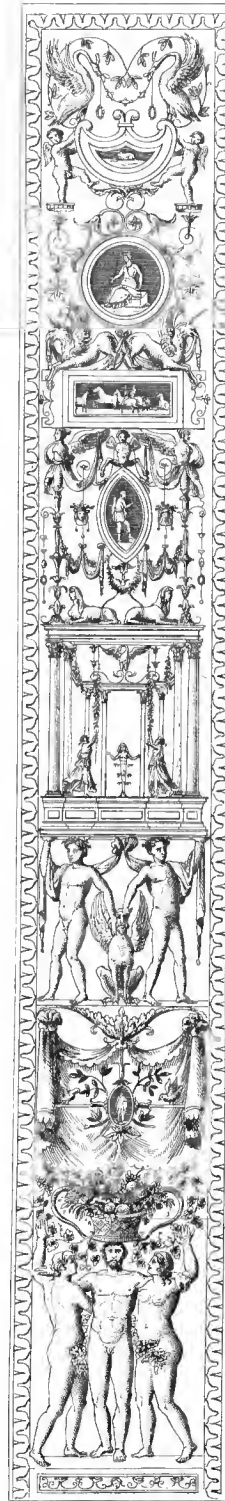


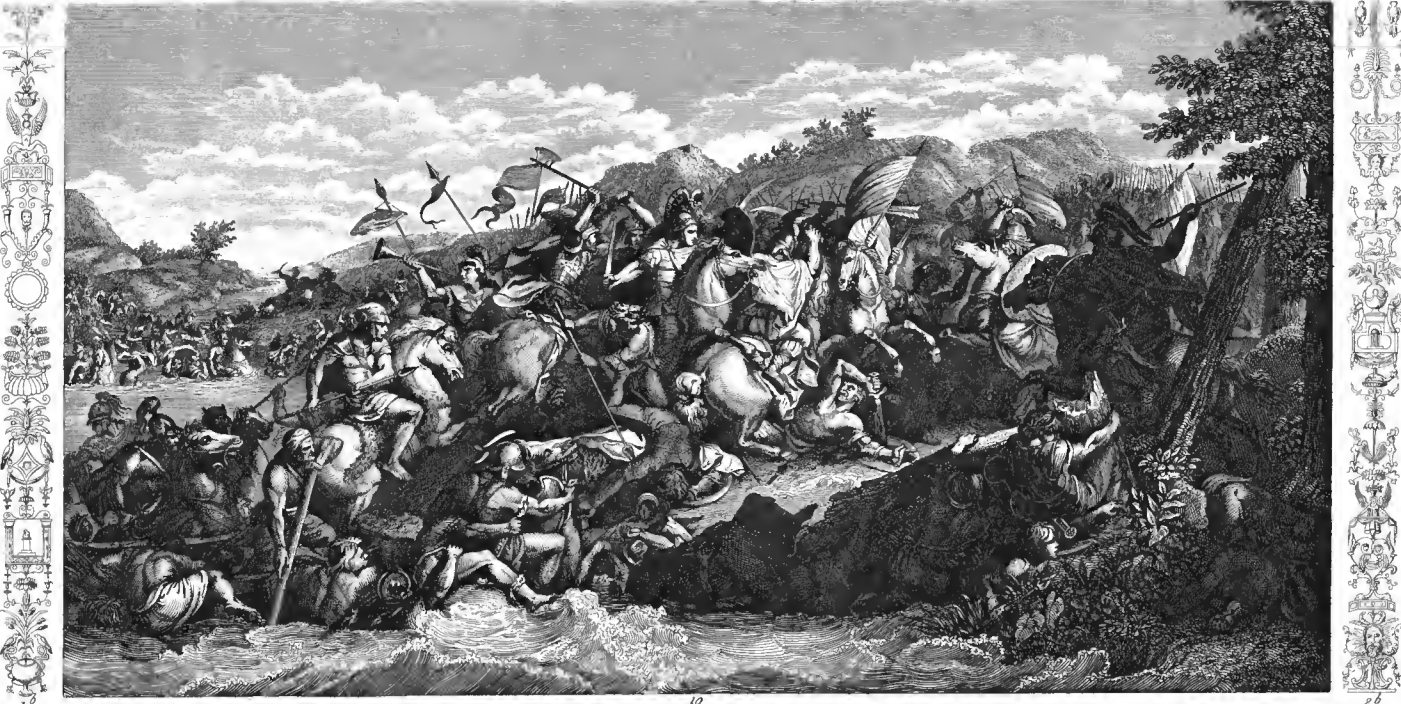


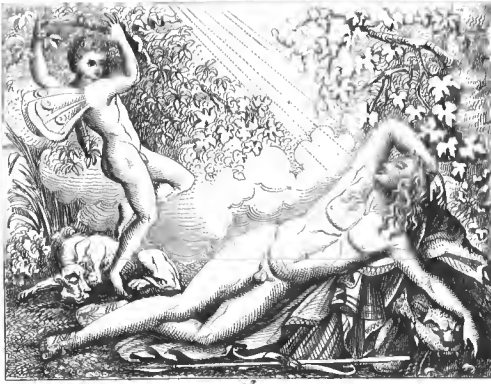
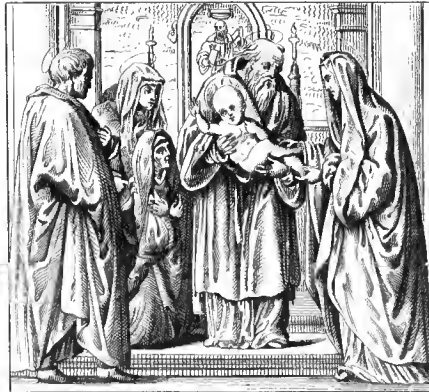


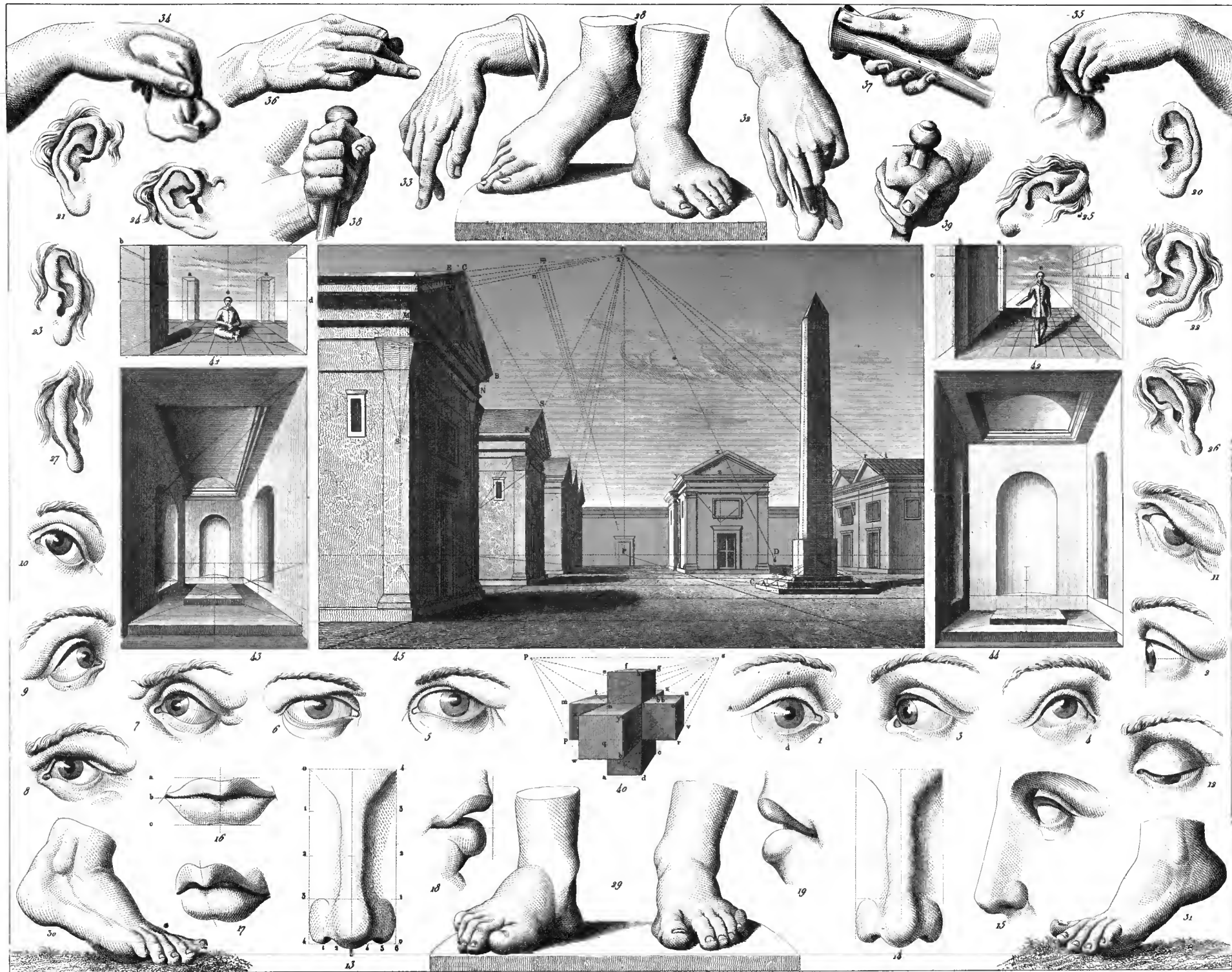


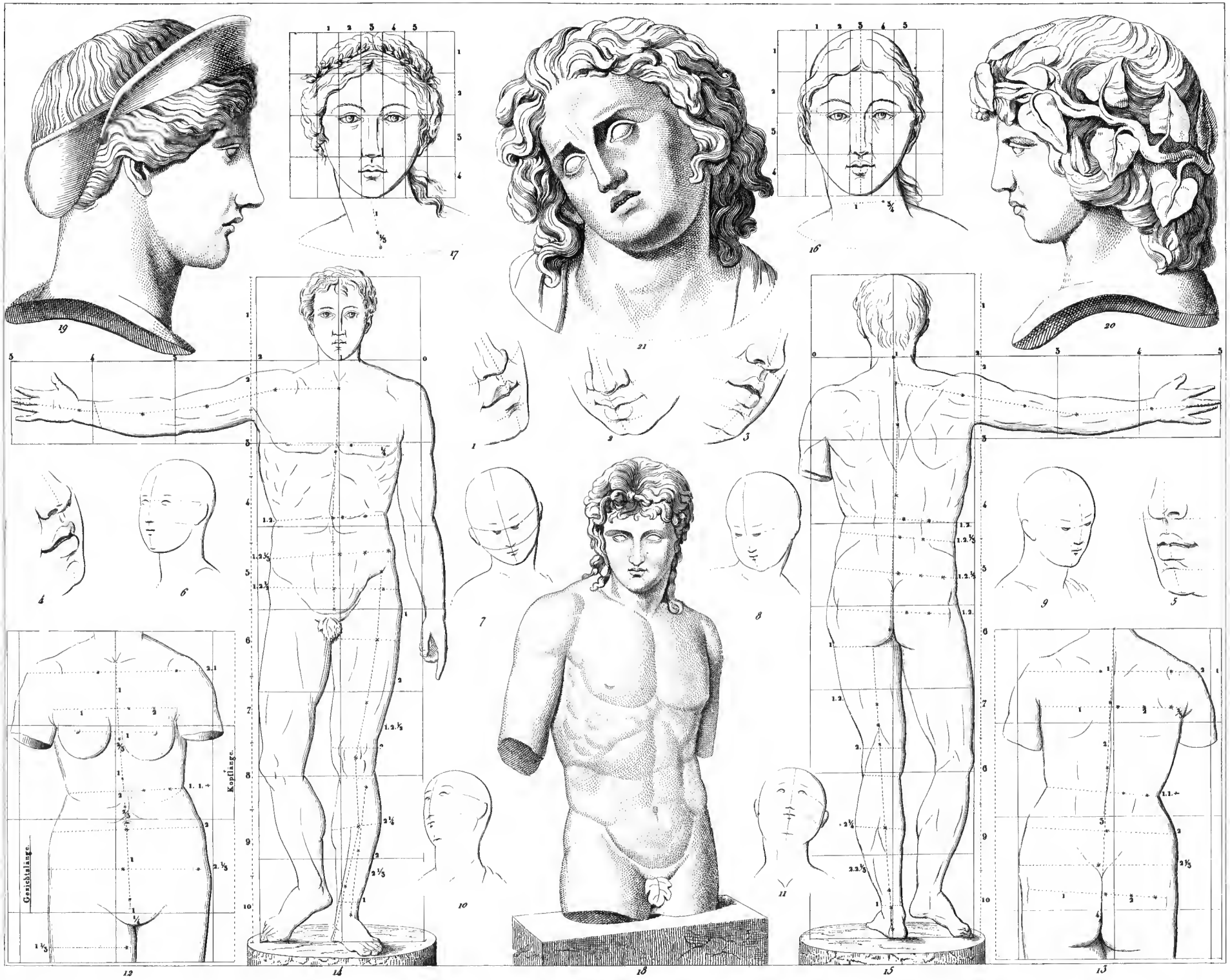


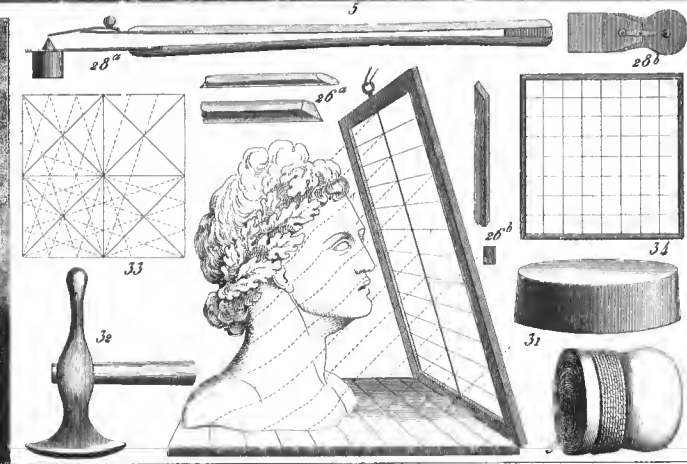
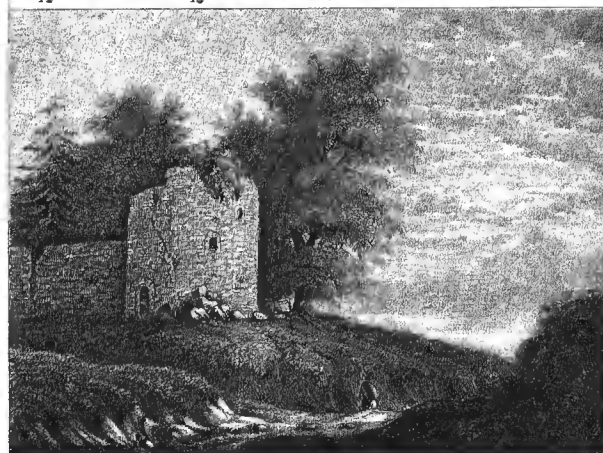
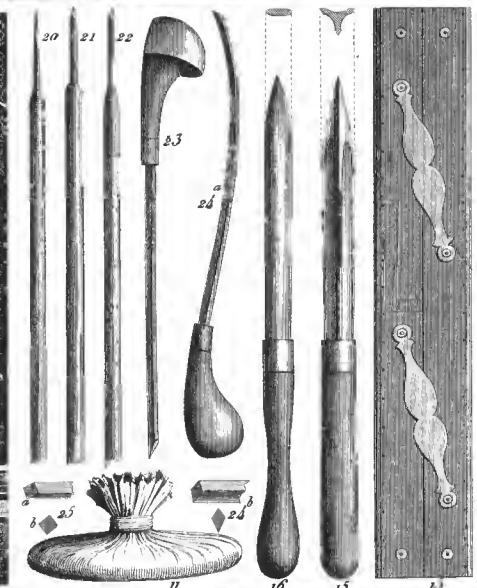
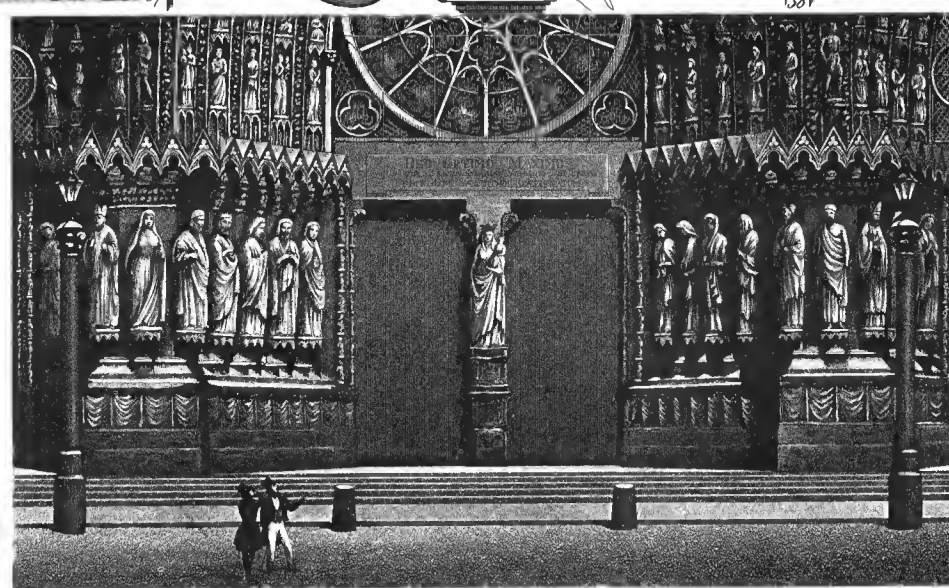
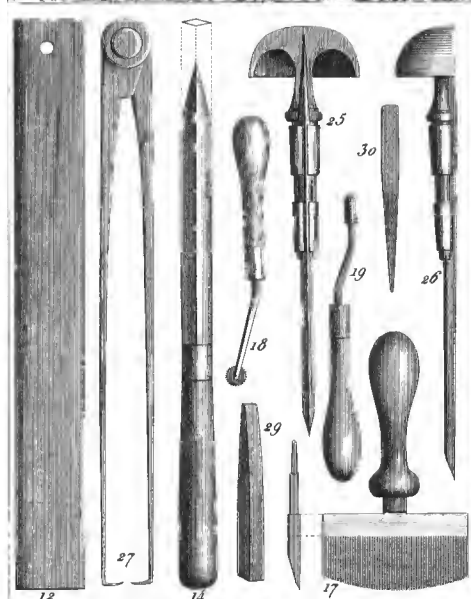
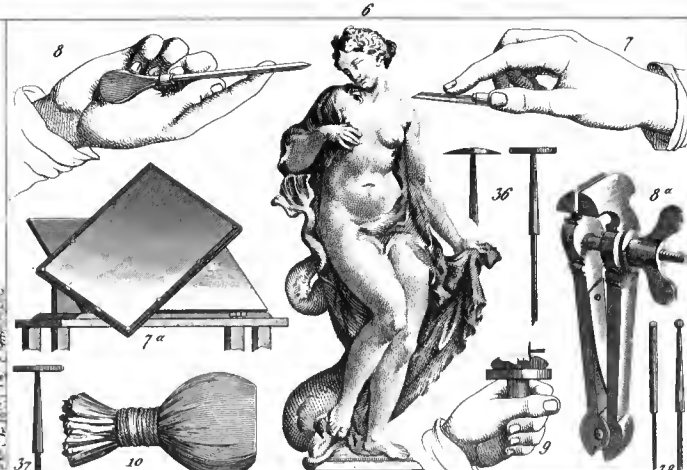












4 Keilschrift

I. Classe.	II. Classe.	III. Classe.	IV. Classe.
𐎀 a	𐎁 d	𐎂 g(da)	𐎃 i
𐎄 h	𐎅 e	𐎆 b	𐎇 k
𐎈 c	𐎉 f	𐎊 q	𐎋 z
𐎌 l	𐎍 z	𐎎 q	𐎏 i
𐎐 m	𐎑 o	𐎒 gh	𐎓 th
𐎔 n	𐎕 p	𐎖 k	𐎗 a
𐎘 r	𐎙 t	𐎚 u	𐎛 c
𐎜 s	𐎝 ds	𐎞 e	𐎟 a
𐎠 u	𐎡 h	𐎢	𐎣

12 Gothicisch

Figur	Werth	Figur	Werth	Figur	Werth	Figur	Werth
𐌰	a	𐌱	q	𐌲	i	𐌳	j
𐌴	b	𐌵	z	𐌶	k	𐌷	u
𐌸	g	𐌹	h	𐌺	l	𐌻	p
𐌽	d	𐌾	th	𐌿	m	𐍀	r
𐍂	e	𐍃	i	𐍄	n	𐍅	s

2 Tamilisch

Figur	Werth
அ	A
ஆ	Ā
இ	I
ஊ	Ī
஋	U
஌	Ū
஍	E
எ	Ē
ஏ	Āi
ஐ	Āu
஑	K
ஒ	Ng
ஓ	Ch
ஔ	D
க	N
஖	T
஗	N
஘	P
ங	M
ஐ	Ch
஑	A, I
ஒ	R
ஓ	L
ஔ	V
க	S
஖	H

15 Runen

Figur	Benennung	Bedeut.	Zahlwerth
ᚠ	Fé	f	1
ᚢ	Ur	u	2
ᚦ	Thurs	th	3
ᚨ	Os	o	4
ᚱ	Reid	r	5
ᚳ	Kaun	k	6
ᚷ	Hagl	h	7
ᚹ	Naud	n	8
ᚻ	Is	i	9
ᚾ	Ar	a	10
ᚿ	Sol	s	11
ᛀ	Tyr	t	12
ᛁ	Biörk	h	13
ᛃ	Laugr	l	14
ᛅ	Madr	m	15
ᚷ	Yr	y	16

3 Bugisch

Figur	Werth
А	A
В	B
Г	G
Д	D
Е	E
Ж	Z
И	I
К	K
Л	L
М	M
Н	N
П	P
Р	R
С	S
Т	T
У	U, V, N
Х	H
Ц	Z
Ч	H

6 Armenisch

Figur	Benennung	Bedeutung	Zahlwerth
Ա	Aip	a	1
Բ	Pjen	p	2
Գ	Kim	k	3
Դ	Ta	t	4
Ե	Jetsch	je e	5
Զ	Za	z gelind	6
Է	E	e	7
Ը	Jeth	e kurz	8
Թ	Tho	th	9
Ճ	She	sh franz.j	10
Լ	Ini	i	20
Լի	Liun	l	30
Շ	Che	ch	40
Ճ	Dsa	ds	50
Ը	Gjen	g	60
Ի	Hho	hh	70
Տ	Tsa	ts	80
Ղ	Ghad	gh	90
Ճ	Dshe	dsh engl.g	100

7 Pehlvi

Figur	Werth
𐭀	A
𐭁	B
𐭂	G
𐭃	D
𐭄	E
𐭅	Z
𐭆	Ē
𐭇	Th
𐭈	I
𐭉	K
𐭊	L
𐭋	M
𐭌	N
𐭍	Xi
𐭎	O

1 Japaneseisch

Figur	Werth	Figur	Werth	Figur	Werth	Figur	Werth	Figur	Werth
イ	I	ル	Rou	ナ	Na	マ	Ma	ユ	You
ロ	Ro	ワ	Wa	ラ	Ra	ケ	Ke	メ	Me
ハ	Fa	カ	Ka	ム	Mou	フ	Fou	ミ	Mi
ニ	Ni	コ	Ko	ウ	Ou	コ	Ko	シ	Si
ホ	Fo	ヨ	Yo	ウ	I	エ	Ye	イ	Ye
ヘ	Fe	タ	Ta	ノ	No	テ	Te	ヒ	Fi
ト	To	レ	Re	ソ	So	ア	A	モ	Mo
チ	Tsi	ツ	Tsou	オ	Wo	サ	Sa	セ	Se
リ	Ri	ツ	Tsou	ク	Kou	ア	Sa	セ	Se
ヌ	Nou	子	Ne	セ	Ya	キ	Ki	ス	Sou

14 An'elsachsisch

Figur		Werth	Figur		Werth	Figur		Werth
Majusculos	Minusculos		Majusculos	Minusculos		Majusculos	Minusculos	
A	a	A	k	k	K	Ð	s	Dh
B	b	B	l	l	L	U	u	U
C	c	C	m	m	M	P	p	W
D	d	D	n	n	N	X	x	X
E	e	E	o	o	O	Y	y	Y
F	f	F	p	p	P	Z	z	Z
G	g	G	r	r	R	Æ	æ	Æ
H	h	H	s	s	S	þ	þ	Th
I	i	I	t	t	T			

9 Alt Griechisch

Figur	Benenn.	Bedeut.	Figur	Benenn.	Bedeut.	Figur	Benenn.	Bedeut.	Zahlwerth
Α	Alpha	a	Β	Beta	b	Γ	Gamma	g	3
Δ	Delta	d	Ε	Epsilon	e kurz	Ζ	Zeta	ds	6
Η	Eta	e lang	Θ	Theta	th	Ι	Iota	i	10
Κ	Kappa	k	Λ	Lambda	l	Μ	My	m	40
Ν	Ny	n	Ξ	Xi	x	Ο	Omikron	o kurz	60
Π	Pi	p	Ρ	Rho	r	Σ	Sigma	s	80
Τ	Tau	t	Υ	Ypsilon	u	Φ	Phi	f	200
Χ	Chi	ch	Ψ	Psi	ps	Ω	Oméga	o lang	400

2 Sanskrit.				3 Tibetisch.				8 Mongolisch.				9 Russisch.				10 Walachisch.															
Alphabet				Alphabet				Consonanten				Vocale				Alphabet															
Figur	Ben.	Bedeut.	Figur	Figur	Ben.	Bedeut.	Figur	zu Anfang	i d Mitte	am Ende	Bedeut.	zu Anfang	i d Mitte	am Ende	Bedeut.	Antiqua	Cursiv	Benennung	Bedeut.	Antiqua	Cursiv	Benennung	Bedeut.	Figur	Benenn.	Bedt.	Figur	Benenn.	Bedt.		
अ	a	langes a	अ	ཀ	k		ཀ	ᠠ				ᠠ				А	А	Ass	a	У	У	U	u	Я	Ahs	a	Оу	ou	u		
आ	ā	langes ā	आ	ཁ	kh	zz	ཁ	ᠡ				ᠡ				Б	Б	Buki	b	Ф	Ф	Fert	f ph	Б	Buke	b	Ф	Ф	Fite	foph	
इ	i	langes i	इ	ག	g	ts	ག	ᠢ				ᠢ				В	В	Wjedi	w	Х	Х	Cherr	ch	В	Vide	v	Х	Х	Chier	ch	
उ	u	langes u	उ	ཅ	ng	dz	ཅ	ᠣ				ᠣ				Г	Г	Glagol	g	Ц	Ц	Zü	z	Г	Glagol	g	Ц	Ц	O	olang	
ऋ	ṛ	langes ṛ	ऋ	ཆ	dsh	w	ཆ	ᠤ				ᠤ				Д	Д	Dobro	d	Ч	Ч	Tscherw	tsch	Д	Dobro	d	Ч	Ч	Zi	z	
ॠ	ṝ	langes ṝ	ॠ	ཇ	tsch	sh	ཇ	ᠥ				ᠥ				Е	Е	Jehst	je e	Ш	Ш	Scha	sch	Е	Jest	elang	Ш	Ш	Tscherf	t	
ऌ	ḷ	langes ḷ	ऌ	ཉ	dsh	s	ཉ	ᠦ				ᠦ				Ж	Ж	Schiwete	sch	Щ	Щ	Schtscha	schtsch	Ж	Ж	Schwet	sch	Щ	Щ	Scha	sch
ॡ	ḹ	langes ḹ	ॡ	ཏ	n	a	ཏ	ᠨ				ᠨ				З	З	Semlja	s	Ъ	Ъ	Jerr	*	З	Selo	2 Ziff.	Ъ	Ъ	Schta	scht	
अः	a:	langes a:	अः	ཐ	n	a	ཐ	ᠯ				ᠯ				И	И	Ische	i	Ы	Ы	Jerü	ü	И	И	Ische	j	Ы	Ы	Jor	ekurz
आः	ā:	langes ā:	आः	ད	t	y	ད	ᠮ				ᠮ				І	І	I	i	Ь	Ь	Jehr	*	І	І	Ische	j	Ь	Ь	Jeat	ea
इः	i:	langes i:	इः	དྷ	th	r	དྷ	ᠮ				ᠮ				К	К	Kako	k	Ъ	Ъ	Jat	je	К	Kako	k	Ъ	Ъ	Ju	ju	
उः	u:	langes u:	उः	ན	th	r	ན	ᠮ				ᠮ				Л	Л	Ljudi	l	Э	Э	E	e	Л	Lude	l	Э	Э	Jako	ja	
ऋः	ṝ:	langes ṝ:	ऋः	པ	d	l	པ	ᠮ				ᠮ				М	М	Müsslete	m	Ю	Ю	Ju	ju	М	Mislete	m	Ю	Ю	Ia	ia	
ॠः	ṝ̄:	langes ṝ̄:	ॠः	ཕ	n	sch	ཕ	ᠮ				ᠮ				Н	Н	Nasch	n	Я	Я	Ja	ja	Н	Nasch	n	Я	Я	Ptita	th	
ऌः	ḹ:	langes ḹ:	ऌः	བ	p	ss	བ	ᠮ				ᠮ				О	О	On	o	Ө	Ө	Pita	f	О	On	o	Ө	Ө	Psi	ps	
ॡः	ḹ̄:	langes ḹ̄:	ॡः	མ	ph	h	མ	ᠮ				ᠮ				П	П	Pokoy	p	У	У	Ischiza	y w	П	Pokoy	p	У	У	X	x	
अः	a:	langes a:	अः	ཙ	b	a	ཙ	ᠮ				ᠮ				Р	Р	Rzü	r	Ѳ	Ѳ			Р	Rize	r	Ѳ	Ѳ	Ypsilon v i'	v i'	
आः	ā:	langes ā:	आः	ཛ			ཛ	ᠮ				ᠮ				С	С	Slowo		ѳ	ѳ			С	Slovo		ѳ	ѳ	En	wüng	
इः	i:	langes i:	इः	ཛྷ			ཛྷ	ᠮ				ᠮ				Т	Т	Twerdo	t	Ѵ	Ѵ			Т	Tverdot		Ѵ	Ѵ	Dscho	dsch	
उः	u:	langes u:	उः	ཞ			ཞ	ᠮ				ᠮ				Т	Т	Uk	u	ѵ	ѵ			Т	Uk	u	ѵ	ѵ			

5 Aethiopisch.										7 Zend.				8 Syrisch.				9 Arabisch.				10 Magadha.				
Figur										Figur				Figur				Figur								
Benenn.	mit ä	mit u	mit l	mit ä	mit ē	mit ē	mit o	Bedt.	Figur	Worth	Figur	Worth	Benenn.	nicht angeschlossen	Figur	Benennung	Zahlwerth	Benenn.	nicht angeschlossen	Figur	Benennung	Zahlwerth	Figur	Worth	Figur	Worth
Hoi	ሀ	ሁ	ሂ	ሃ	ሄ	ህ	ሆ	h	ሀ	𑀀	𑀁	𑀂	Olaph	𐌀	𐌁	Spiritlenit.	1	Elif	𐌀	𐌁	𐌂	1	𑀃	𑀄	𑀅	N
Lawi	ለ	ሉ	ሊ	ላ	ሌ	ል	ሎ	l	ለ	𑀆	𑀇	𑀈	Beth	𐌂	𐌃	b v	2	Be	𐌂	𐌃	𐌄	2	𑀆	𑀇	𑀈	T
Haut	ሀ	ሁ	ሂ	ሃ	ሄ	ህ	ሆ	h	ሀ	𑀉	𑀊	𑀋	Gomal	𐌄	𐌅	g	3	Te	𐌄	𐌅	𐌆	3	𑀉	𑀊	𑀋	Th
Mai	መ	ሙ	ሚ	ማ	ሜ	ሞ	ሟ	m	መ	𑀌	𑀍	𑀎	Dolath	𐌆	𐌇	d	4	The	𐌆	𐌇	𐌈	4	𑀌	𑀍	𑀎	D
Saut	ሠ	ሡ	ሢ	ሣ	ሤ	ሥ	ሦ	s	ሠ	𑀏	𑀐	𑀑	He	𐌈	𐌉	h	5	Hha	𐌈	𐌉	𐌊	5	𑀏	𑀐	𑀑	Dh
Res	ረ	ሩ	ሪ	ራ	ራ	ራ	ራ	r	ረ	𑀒	𑀓	𑀔	Vau	𐌊	𐌋	w oder v	6	Kha	𐌊	𐌋	𐌌	6	𑀒	𑀓	𑀔	Kh
Schaat	ረ	ሩ	ሪ	ራ	ራ	ራ	ራ	r	ረ	𑀕	𑀖	𑀗	Zain	𐌋	𐌌	der Griech	7	Dal	𐌋	𐌌	𐌍	7	𑀕	𑀖	𑀗	N
Kaf	ቀ	ቁ	ቂ	ቃ	ቄ	ቅ	ቆ	k	ቀ	𑀘	𑀙	𑀚	Cheth	𐌌	𐌍	ch oder kh	8	Re	𐌌	𐌍	𐌎	8	𑀘	𑀙	𑀚	P
Beth	ቀ	ቁ	ቂ	ቃ	ቄ	ቅ	ቆ	k	ቀ	𑀛	𑀜	𑀝	Teth	𐌍	𐌎	t	9	Ze	𐌍	𐌎	𐌏	9	𑀛	𑀜	𑀝	Ph
Thawi	ቀ	ቁ	ቂ	ቃ	ቄ	ቅ	ቆ	k	ቀ	𑀞	𑀟	𑀠	Jud	𐌎	𐌏	i	10	Sin	𐌎	𐌏	𐌐	10	𑀞	𑀟	𑀠	B
Tjawi	ቀ	ቁ	ቂ	ቃ	ቄ	ቅ	ቆ	k	ቀ	𑀡	𑀢	𑀣	Coph	𐌏	𐌐	k ch	20	Schin	𐌏	𐌐	𐌑	20	𑀡	𑀢	𑀣	Bh
Harm	ቀ	ቁ	ቂ	ቃ	ቄ	ቅ	ቆ	k	ቀ	𑀤	𑀥	𑀦	Lomad	𐌐	𐌑	l	30	Sad	𐌐	𐌑	𐌒	30	𑀤	𑀥	𑀦	M
Nahas	ቀ	ቁ	ቂ	ቃ	ቄ	ቅ	ቆ	k	ቀ	𑀧	𑀨	𑀩	Mim	𐌑	𐌒	m	40	Ddad	𐌑	𐌒	𐌓	40	𑀧	𑀨	𑀩	Y
Gnahas	ቀ	ቁ	ቂ	ቃ	ቄ	ቅ	ቆ	k	ቀ	𑀪	𑀫	𑀬	Nun	𐌒	𐌓	n	50	Ta	𐌒	𐌓	𐌔	50	𑀪	𑀫	𑀬	R
Alph	አ	አ	አ	አ	አ	አ	አ	a	አ	𑀭	𑀮	𑀯	Semath	𐌓	𐌔	s	60	Ain	𐌓	𐌔	𐌕	60	𑀭	𑀮	𑀯	L
Kaf	ቀ	ቁ	ቂ	ቃ	ቄ	ቅ	ቆ	k	ቀ	𑀰	𑀱	𑀲	Eo	𐌔	𐌕	d Hebrae	70	rChain	𐌔	𐌕	𐌖	70	𑀰	𑀱	𑀲	V
Chaf	ቀ	ቁ	ቂ	ቃ	ቄ	ቅ	ቆ	k	ቀ	𑀳	𑀴	𑀵	Pho	𐌕	𐌖	p oder f	80	Fe	𐌕	𐌖	𐌗	80	𑀳	𑀴	𑀵	S
Wawe	ወ	ወ	ወ	ወ	ወ	ወ	ወ	w	ወ	𑀶	𑀷	𑀸	Tsodo	𐌖	𐌗	ts z	90	Kaf	𐌖	𐌗	𐌘	90	𑀶	𑀷	𑀸	H
Ain	አ	አ	አ	አ	አ	አ	አ	a	አ	𑀹	𑀺	𑀻	Kuph	𐌗	𐌘	k m d Kehle	100	Lam	𐌗	𐌘	𐌙	100	𑀹	𑀺	𑀻	Mh
Zai	ሀ	ሁ	ሂ	ሃ	ሄ	ህ	ሆ	h	ሀ	𑀼	𑀽	𑀾	Riseh	𐌘	𐌙	r	200	Mim	𐌘	𐌙	𐌚	200	𑀼	𑀽	𑀾	
Jai	ሀ	ሁ	ሂ	ሃ	ሄ	ህ	ሆ	h	ሀ	𑀿	𑁀	𑁁	Schin	𐌙	𐌚	scl	300	Nun	𐌙	𐌚	𐌛	300	𑀿	𑁀	𑁁	
Jaman	ሀ	ሁ	ሂ	ሃ	ሄ	ህ	ሆ	h	ሀ	𑁂	𑁃	𑁄	Thau	𐌚	𐌛	th	400	Ho	𐌚	𐌛	𐌜	400	𑁂	𑁃	𑁄	
Dent	ሀ	ሁ	ሂ	ሃ	ሄ	ህ	ሆ	h	ሀ	Interpunctionszeichen der Zendschrift																
Djent	ሀ	ሁ	ሂ	ሃ	ሄ	ህ	ሆ	h	ሀ																	
Geml	ሀ	ሁ	ሂ	ሃ	ሄ	ህ	ሆ	h	ሀ																	
Tait	ሀ	ሁ	ሂ	ሃ	ሄ	ህ	ሆ	h	ሀ																	
Pait	ሀ	ሁ	ሂ	ሃ	ሄ	ህ	ሆ	h	ሀ																	
Tzada	ሀ	ሁ	ሂ	ሃ	ሄ	ህ	ሆ	h	ሀ																	
Zappa	ሀ	ሁ	ሂ	ሃ	ሄ	ህ	ሆ	h	ሀ																	
Af	ሀ	ሁ	ሂ	ሃ	ሄ	ህ	ሆ	h	ሀ																	
Psa	ሀ	ሁ	ሂ	ሃ	ሄ	ህ	ሆ	h	ሀ																	

Bemerkungen.
 * Jerr giebt dem vorhergehenden Consonant einen stärkeren Ton.
 ** Jehr nimmt dem vorhergehenden Consonant seine Härte.
 *** Die serbische Sprache wird mit russischen Typen gesetzt, bloß mit Hinzufügung obiger Buchstaben.

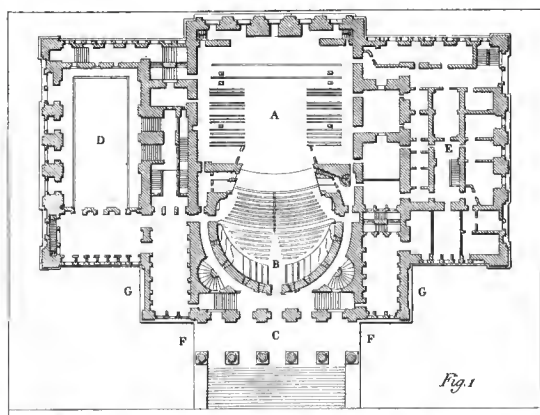


Fig. 1

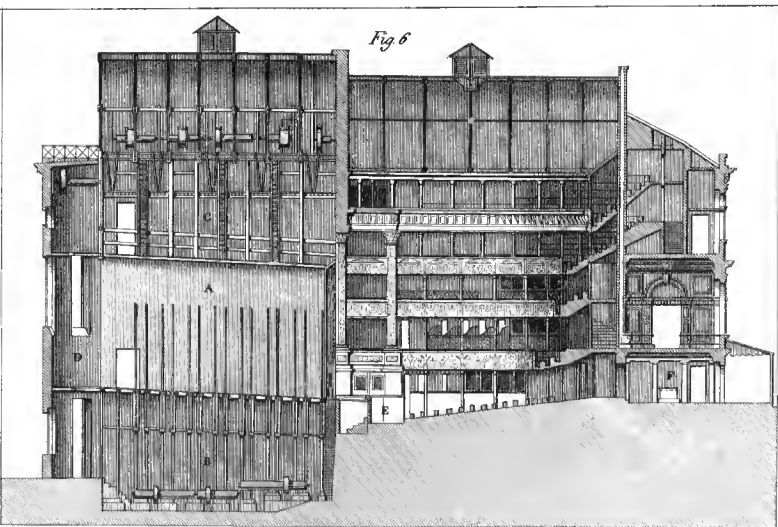


Fig. 6

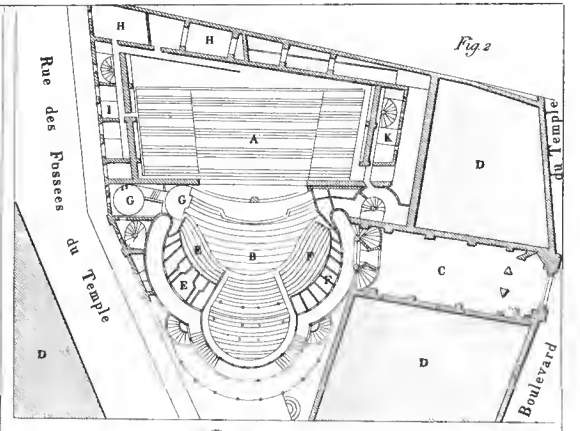


Fig. 2

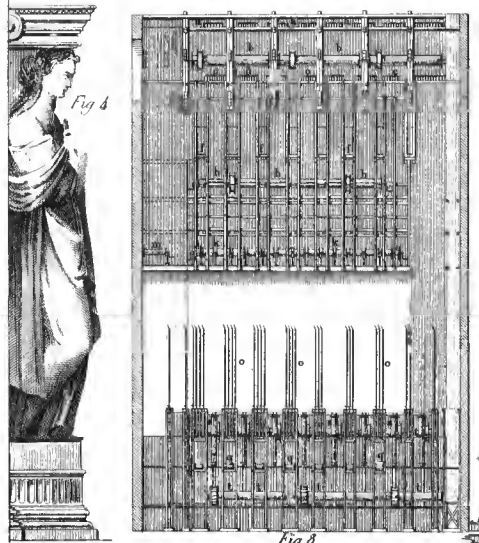


Fig. 4

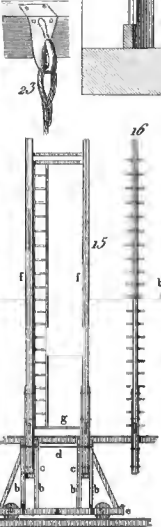


Fig. 8

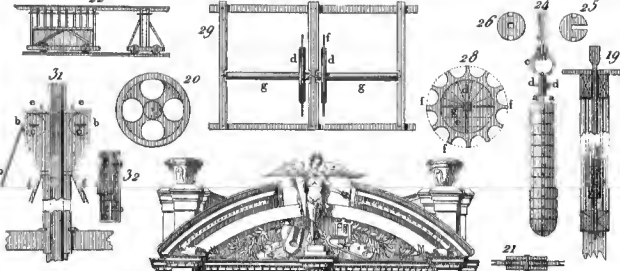


Fig. 3

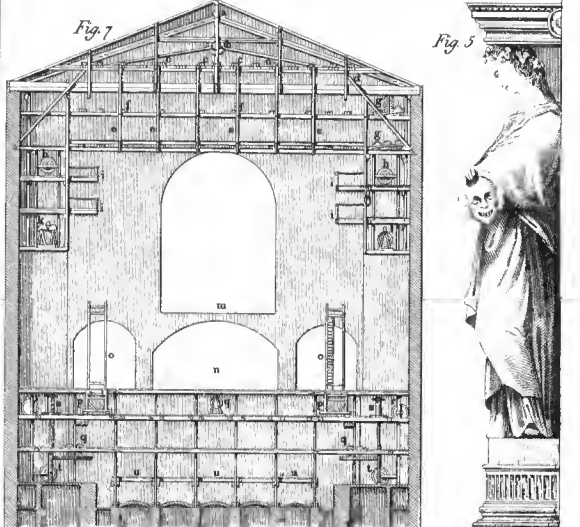


Fig. 7

Fig. 5

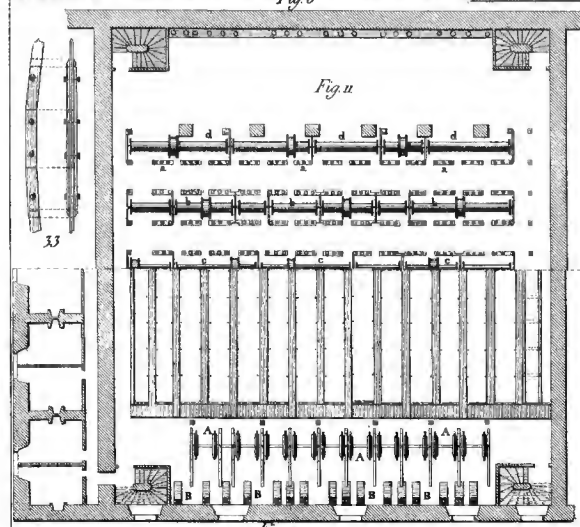


Fig. 11



Fig. 9

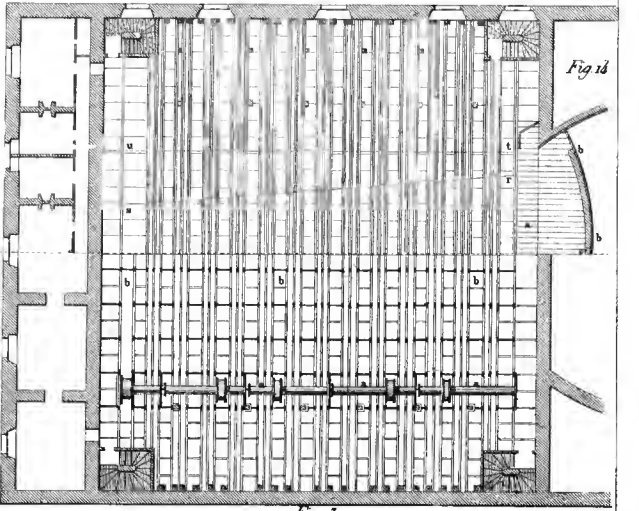
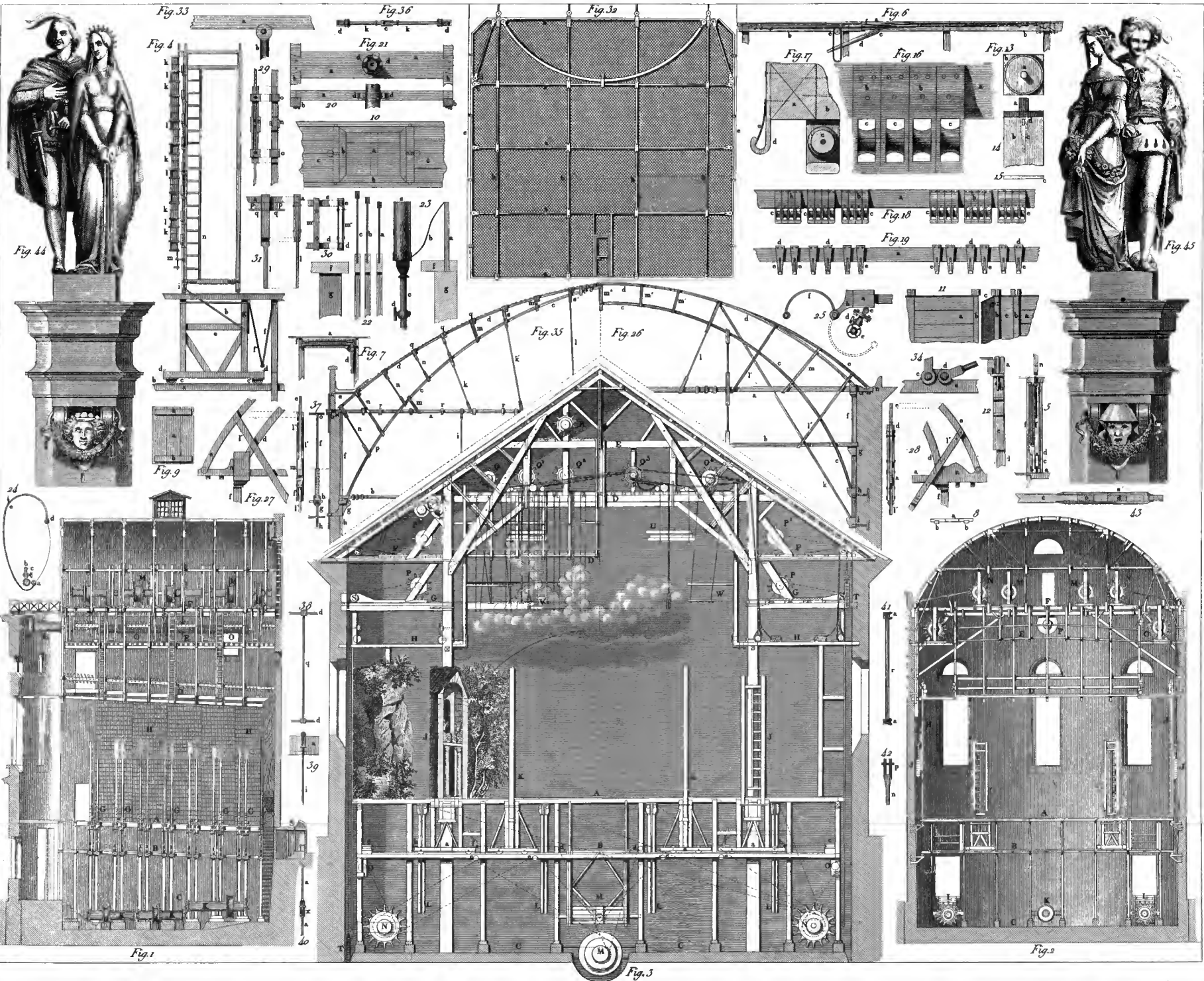



Fig. 10





ICONOGRAPHIC
E N C Y C L O P Æ D I A .

DIVISION X.

TECHNOLOGY.

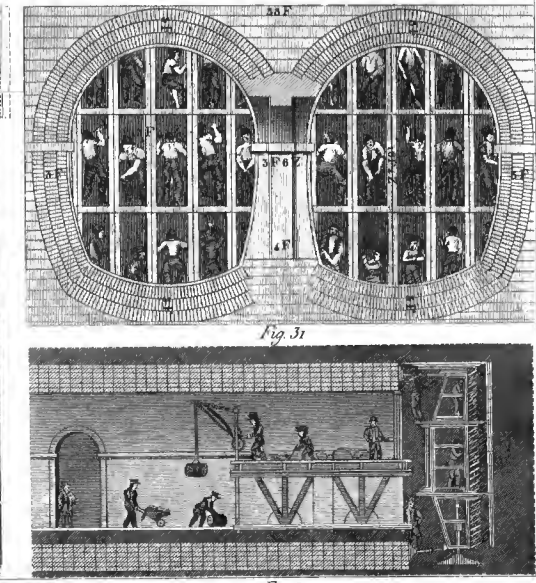
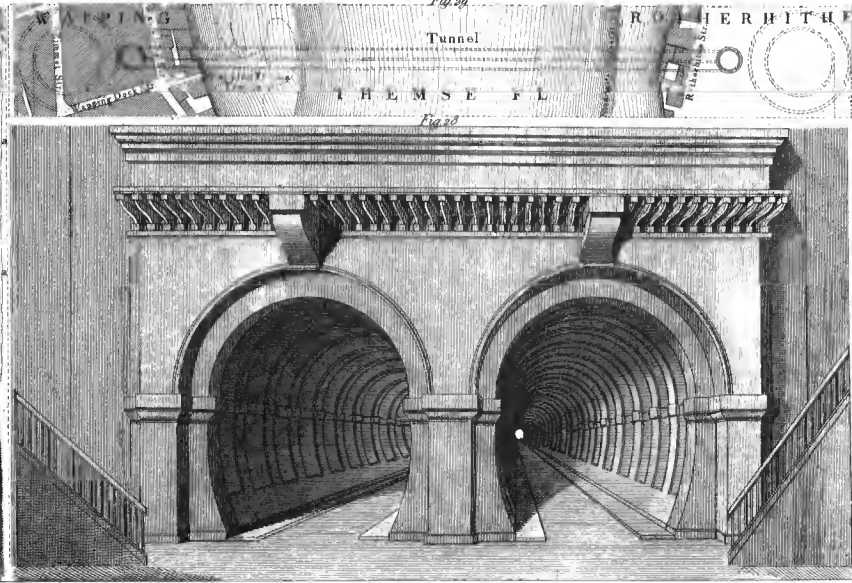
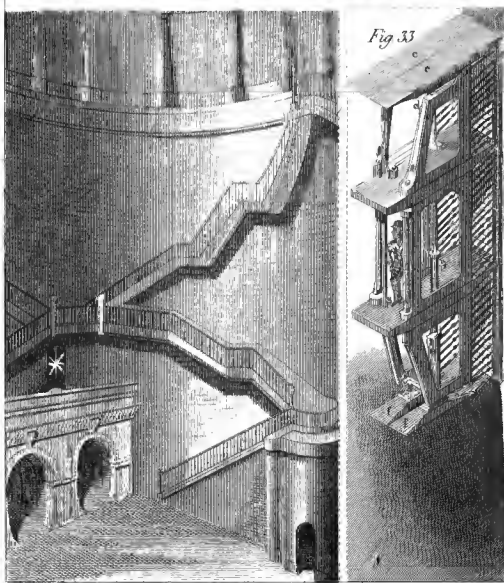
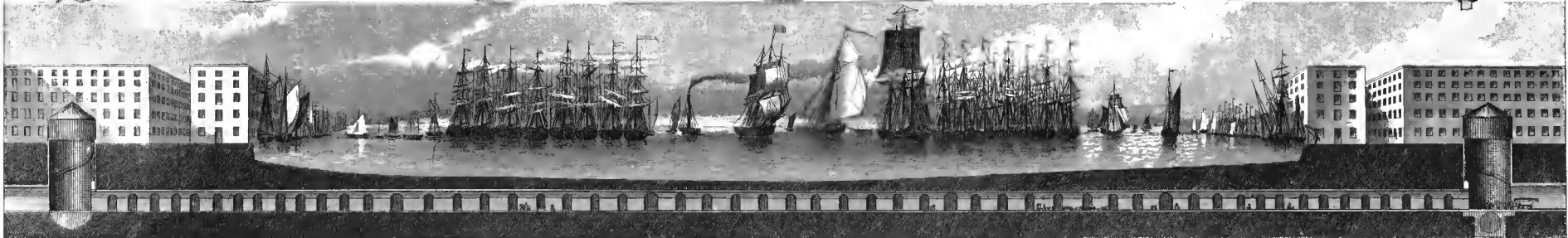
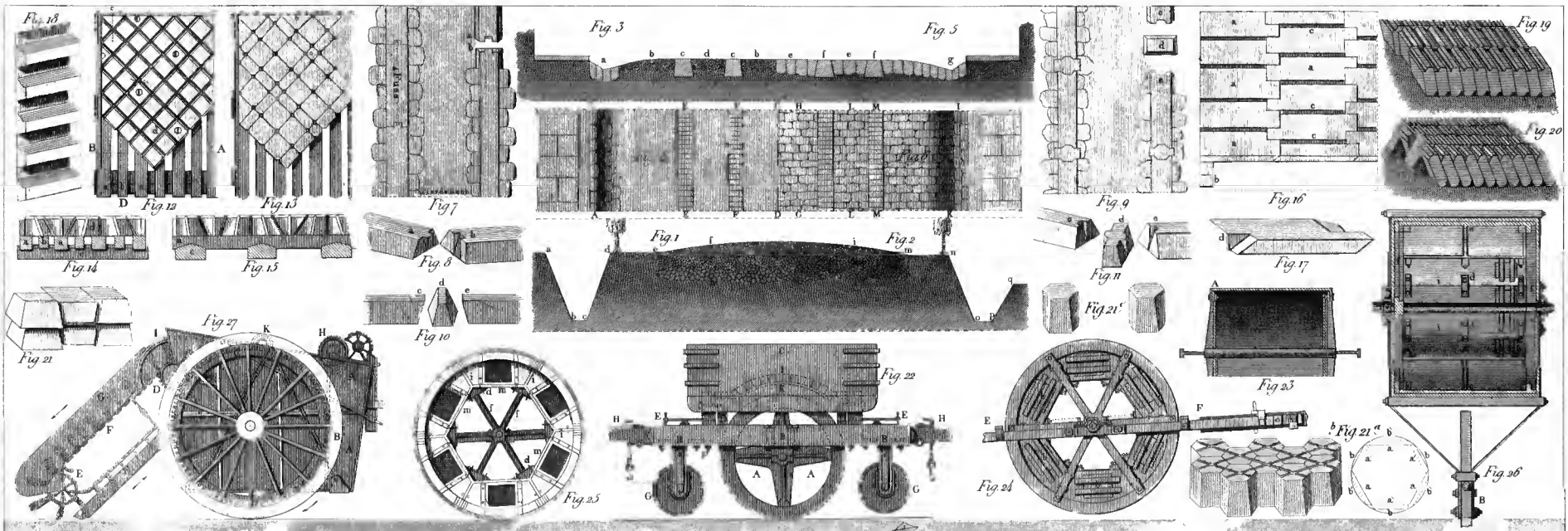
COMPRISING

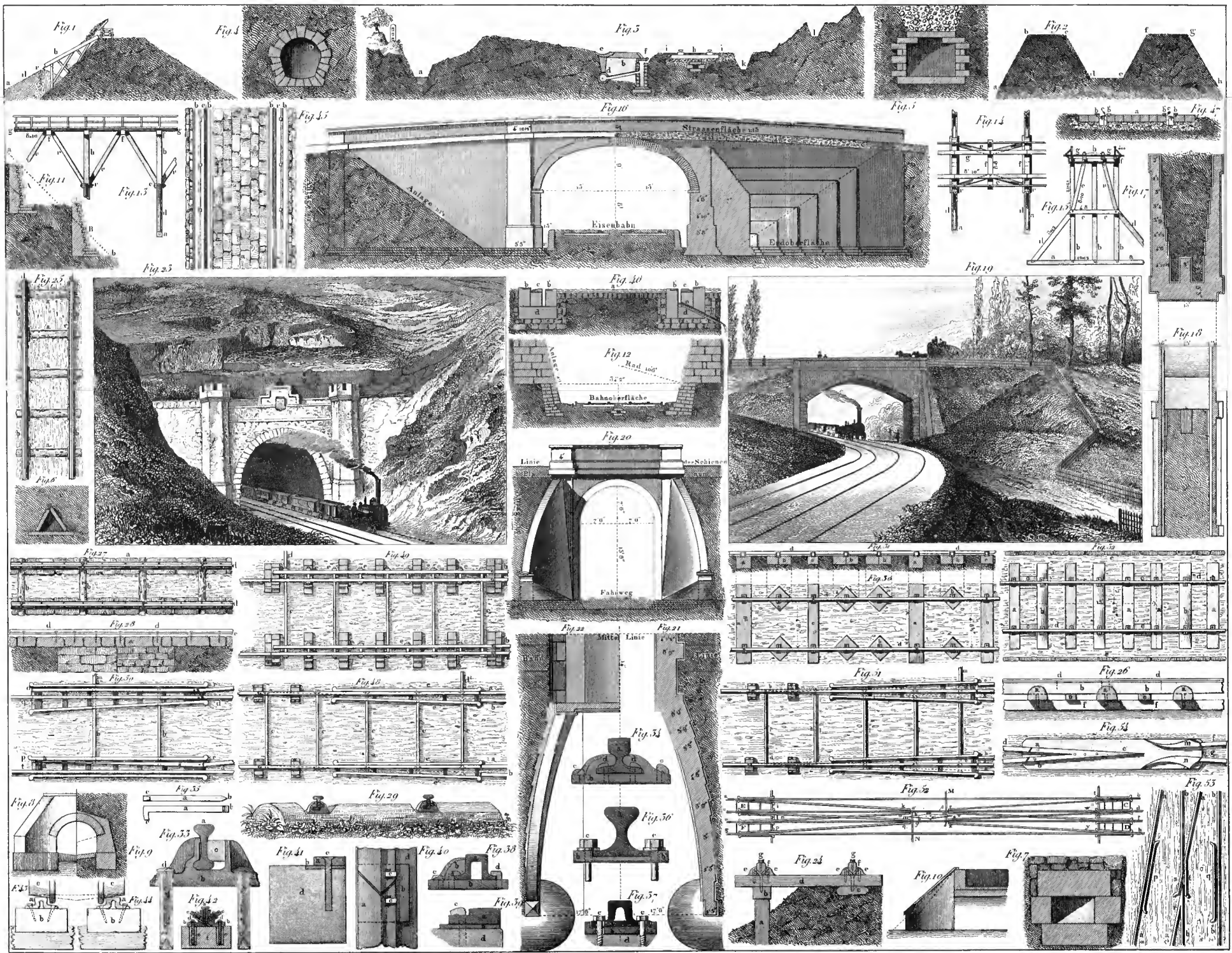
RAILWAYS, CANALS, INDUSTRIAL AND AGRICULTURAL MACHINES, MINING, &c.

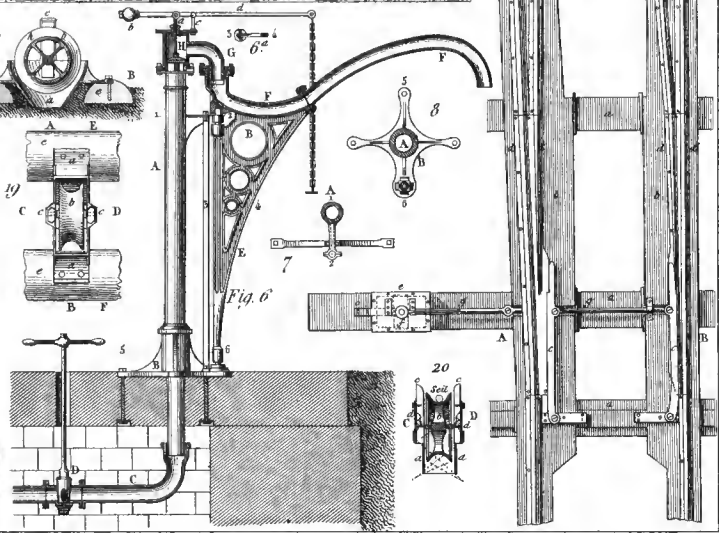
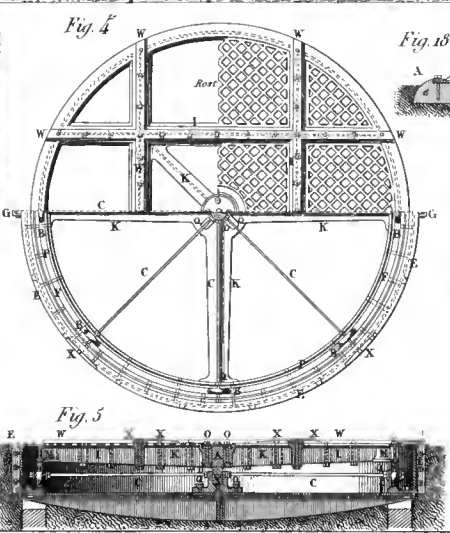
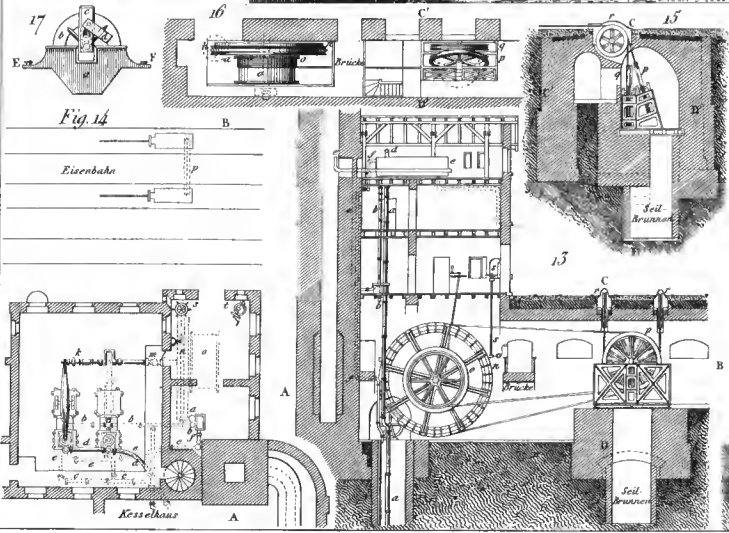
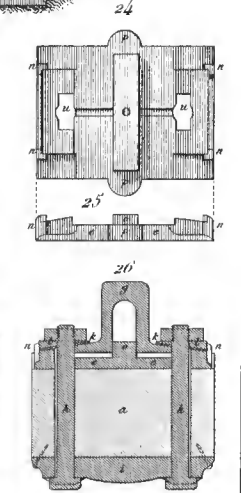
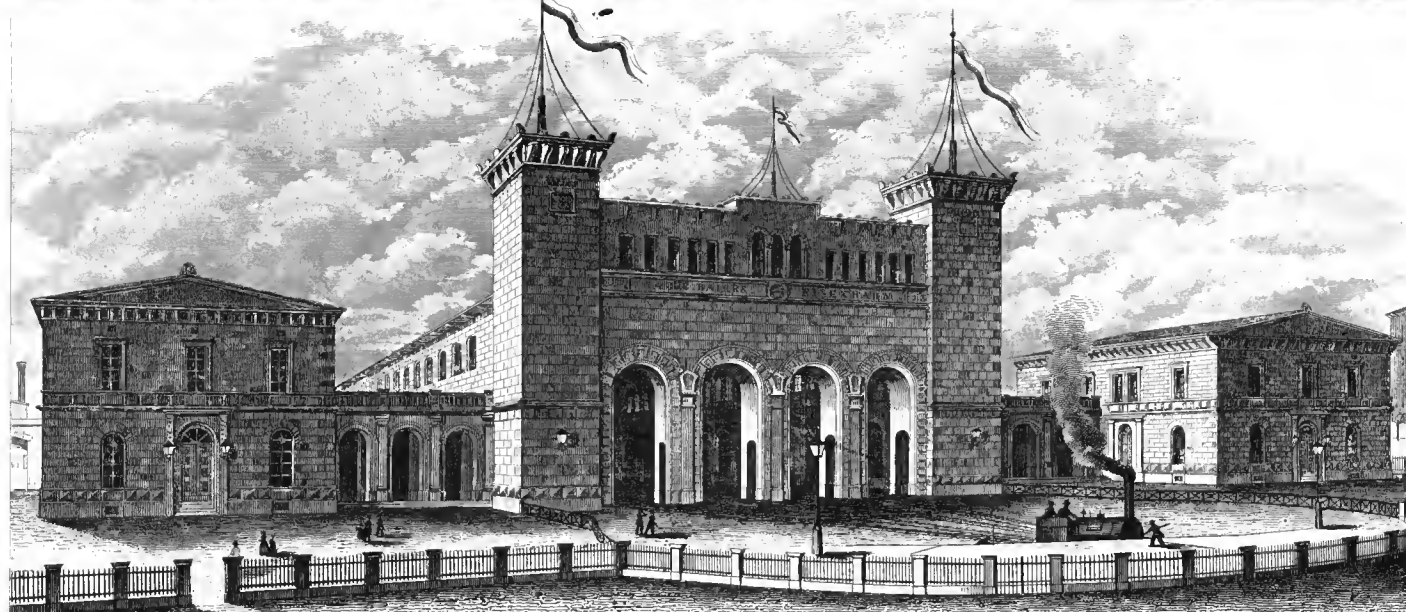
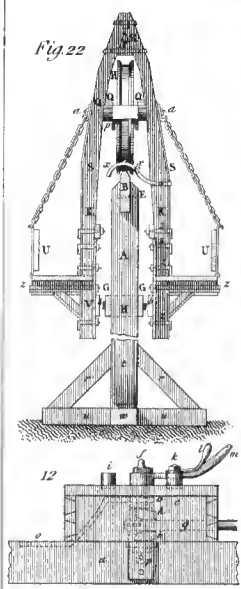
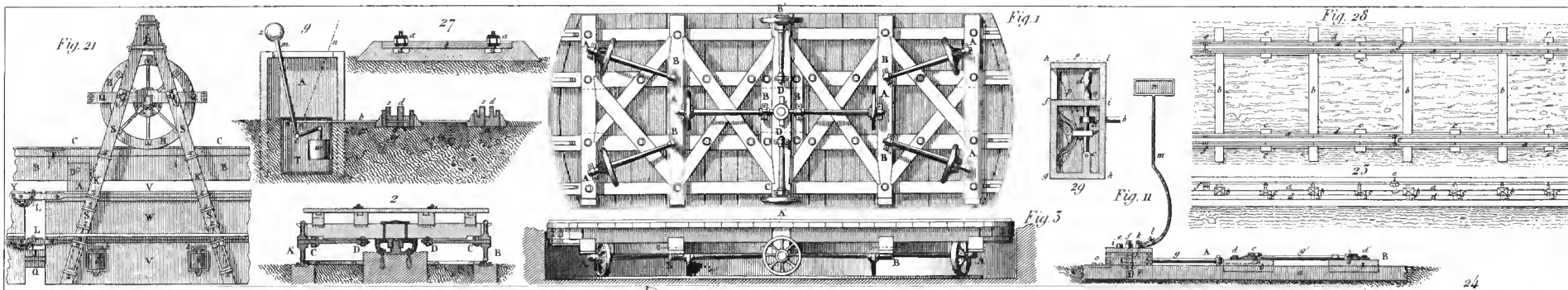
THIRTY-FIVE PLATES.

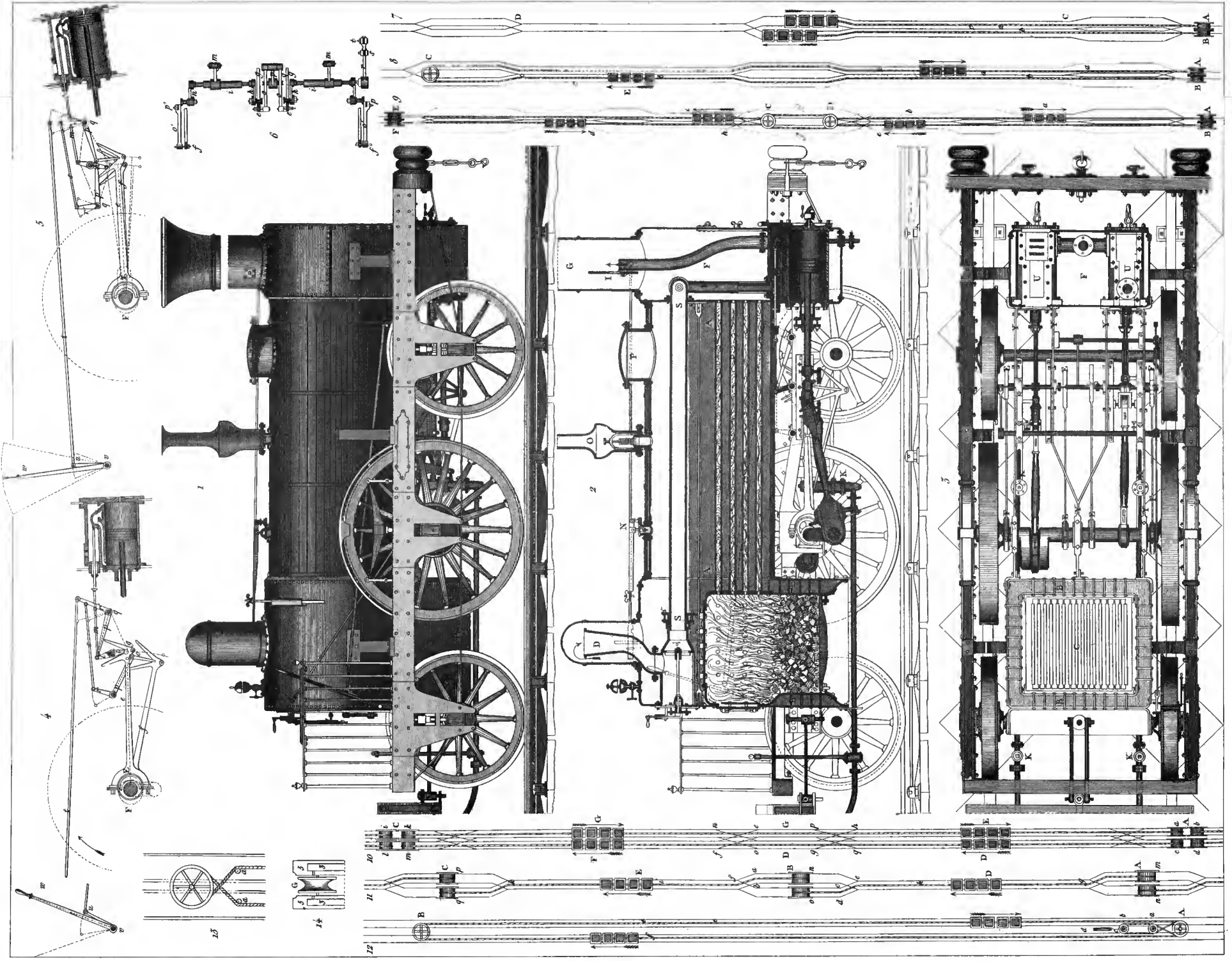
NEW YORK: 1851.
PUBLISHED BY RUDOLPH GARRIGUE,
2 BARCLAY STREET (ASTOR HOUSE).











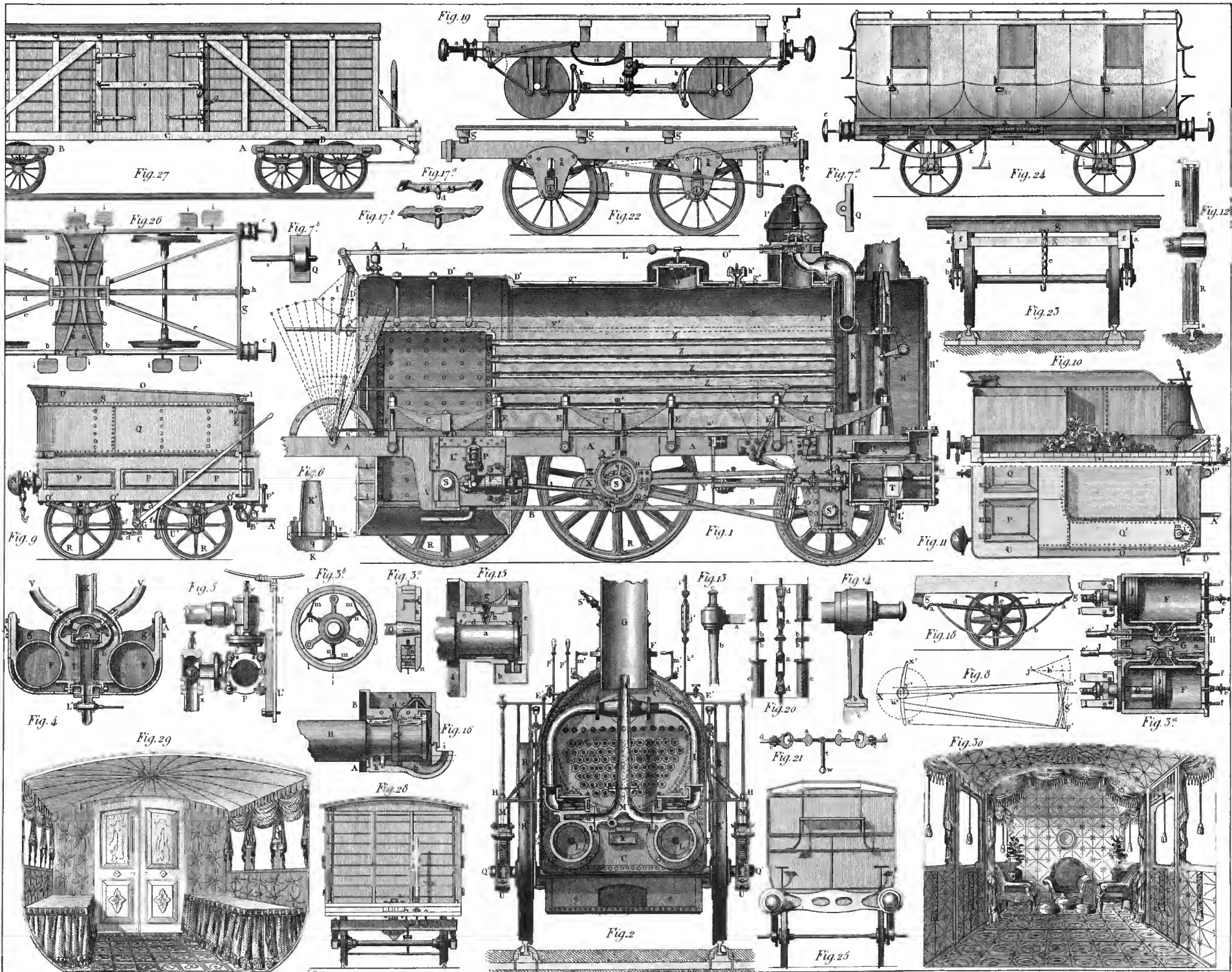


Fig. 27

Fig. 19

Fig. 7^a

Fig. 24

Fig. 20

Fig. 17^a

Fig. 22

Fig. 12

Fig. 7^b

Fig. 23

Fig. 10

Fig. 9

Fig. 6

Fig. 1

Fig. 11

Fig. 4

Fig. 5

Fig. 3^b

Fig. 3^c

Fig. 15

Fig. 13

Fig. 4

Fig. 18

Fig. 5^c

Fig. 29

Fig. 16

Fig. 8

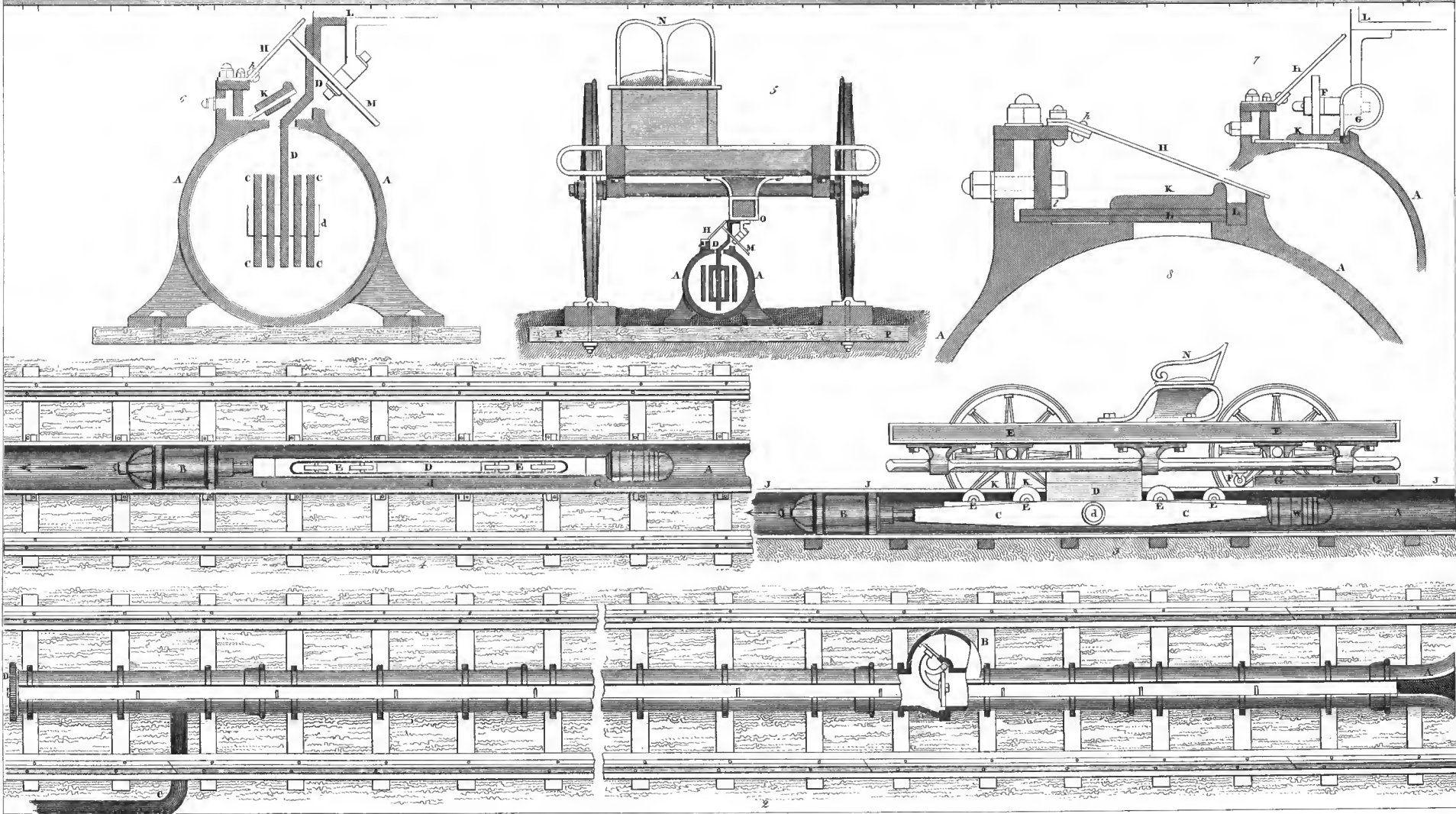
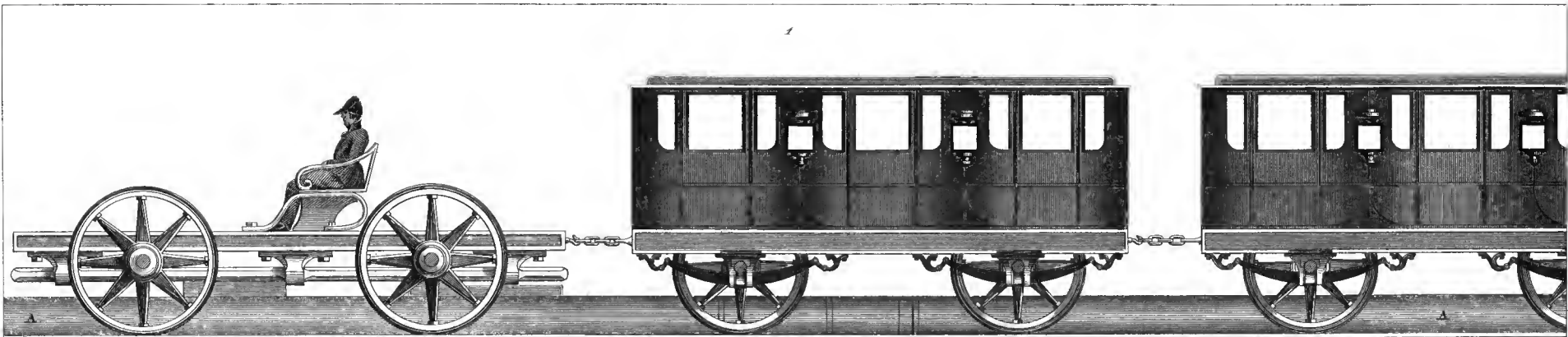
Fig. 28

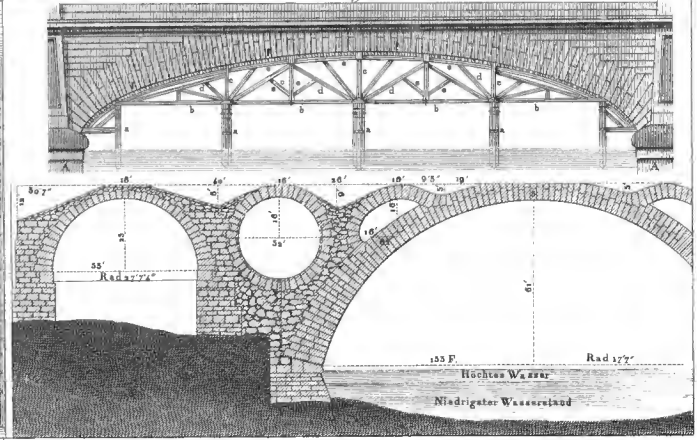
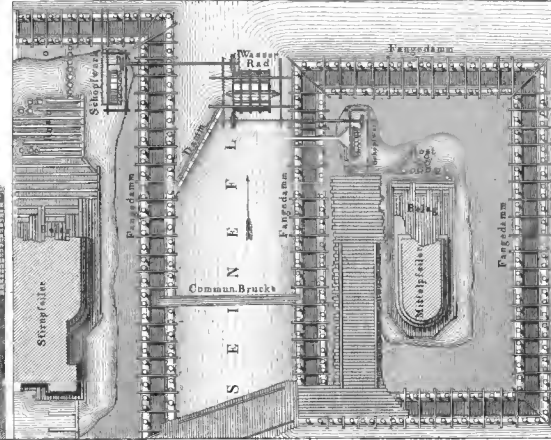
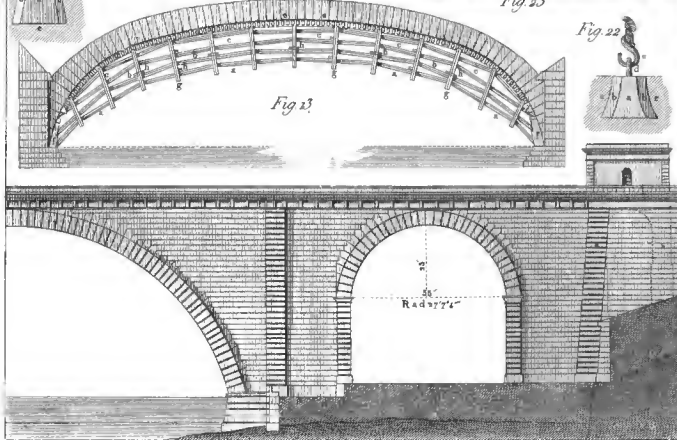
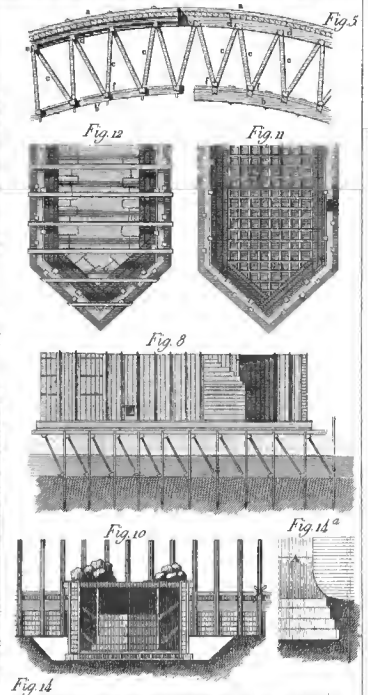
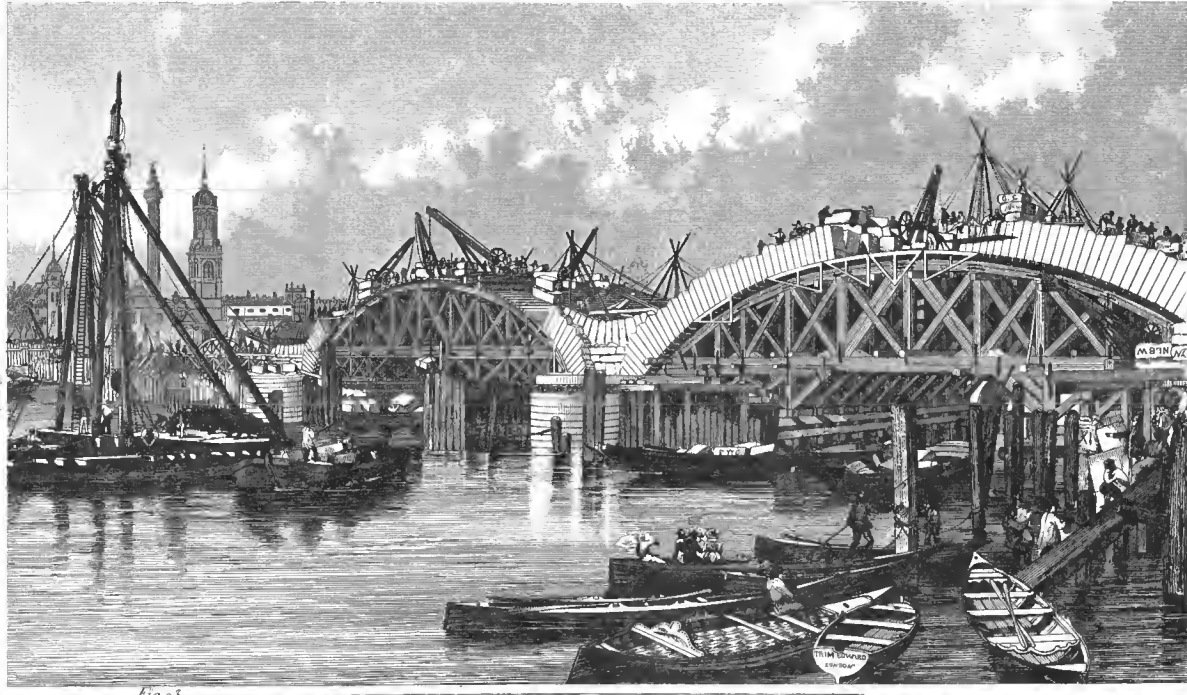
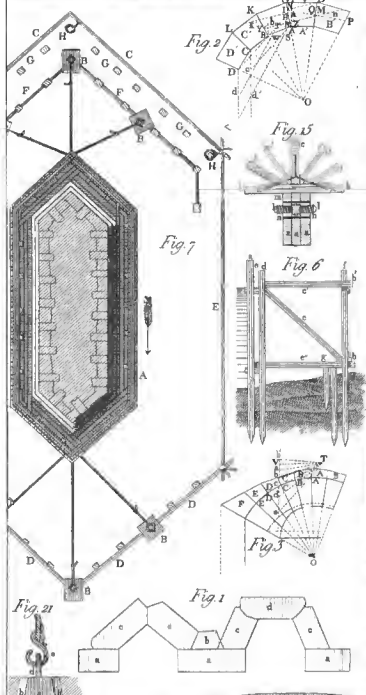
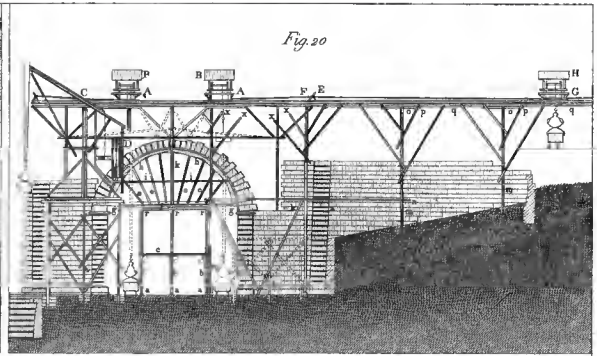
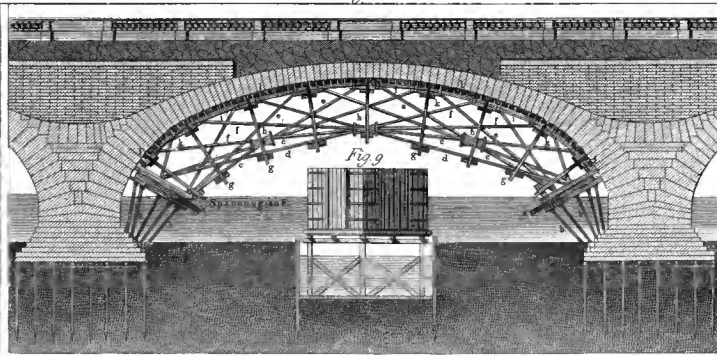
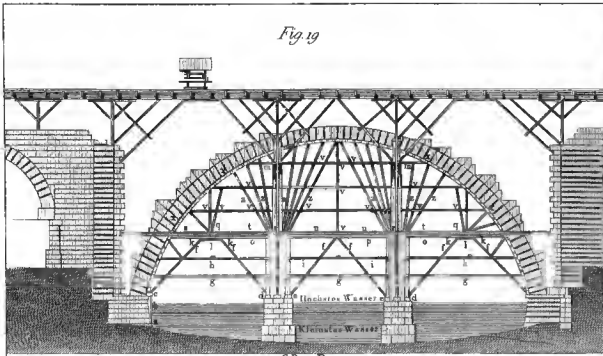
Fig. 2

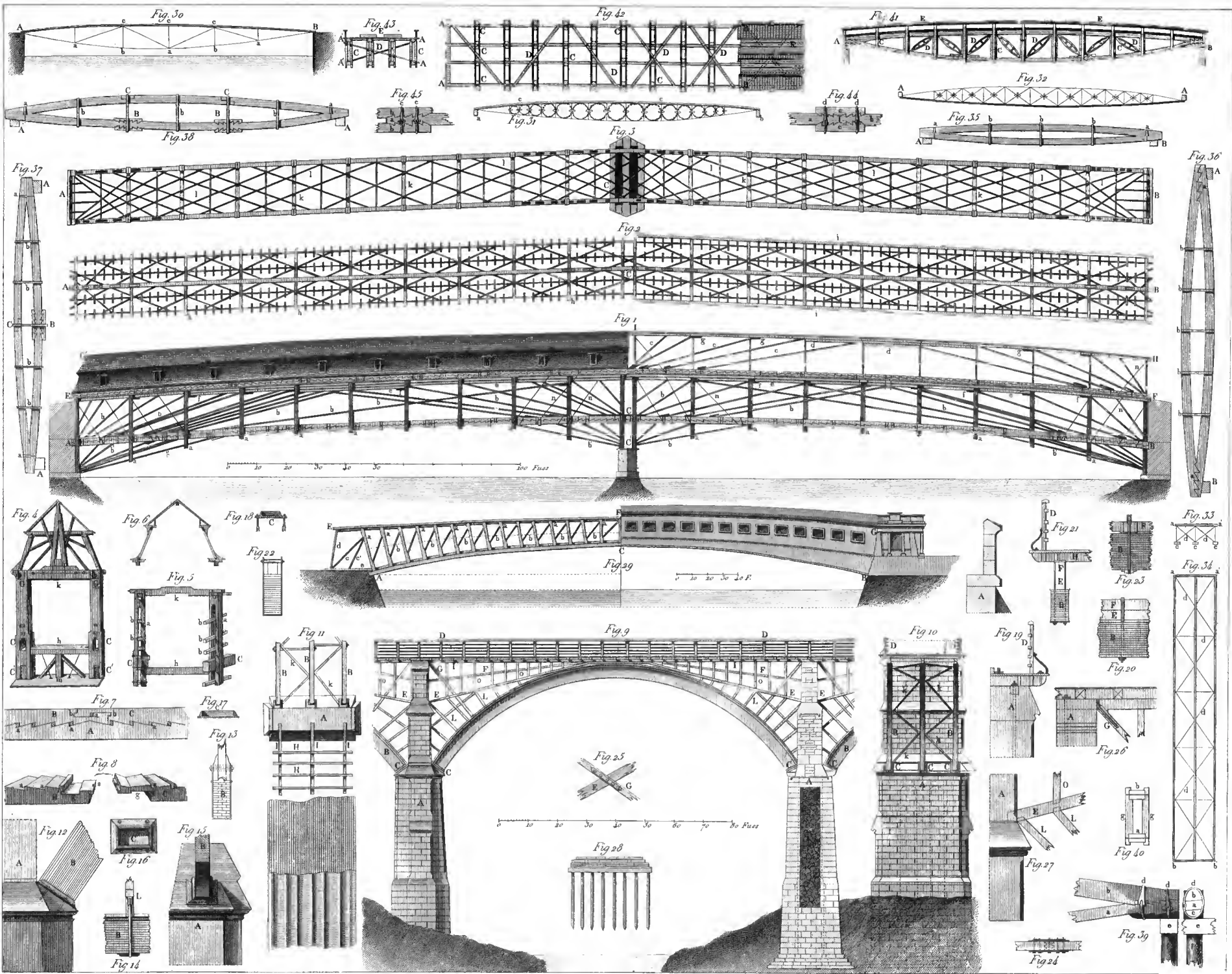
Fig. 21

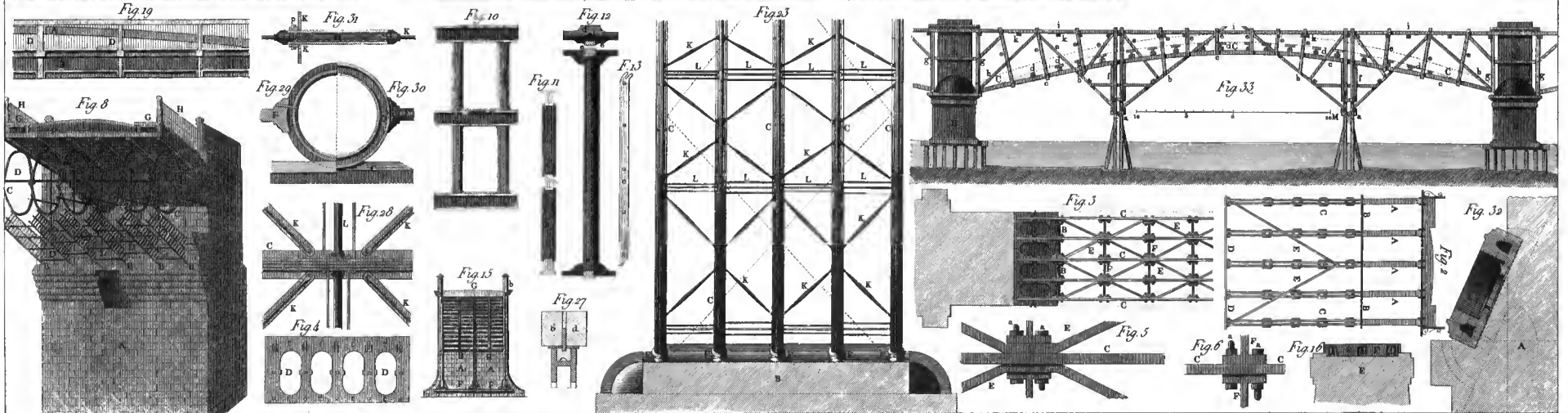
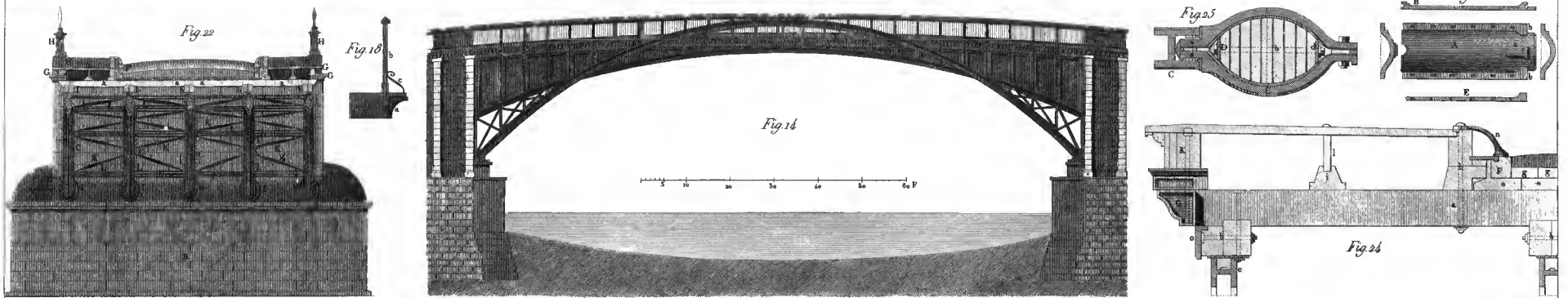
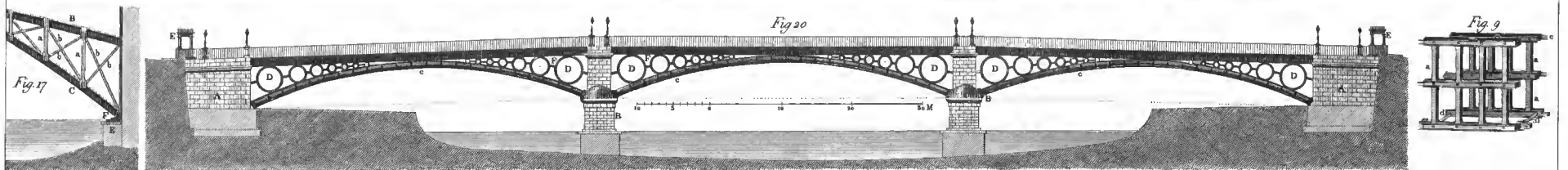
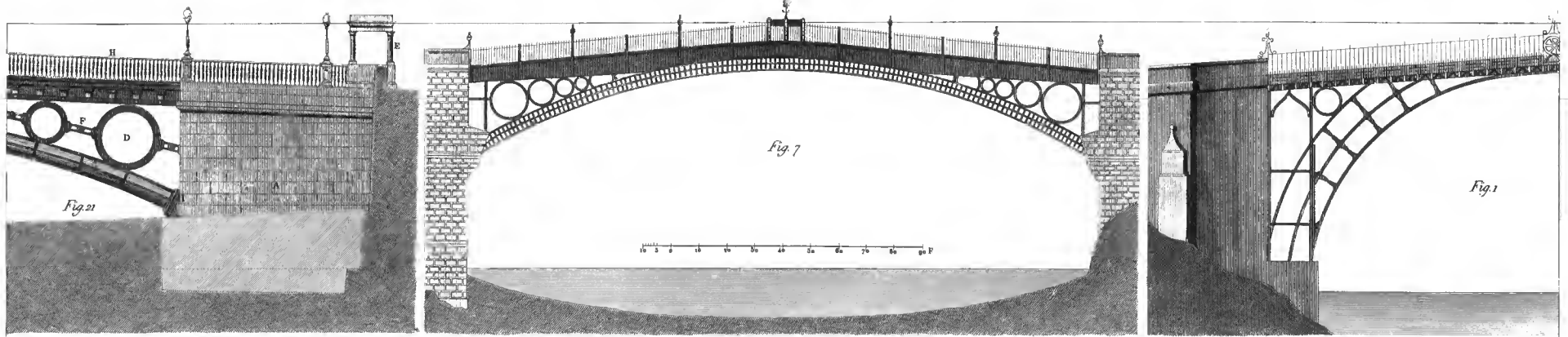
Fig. 25

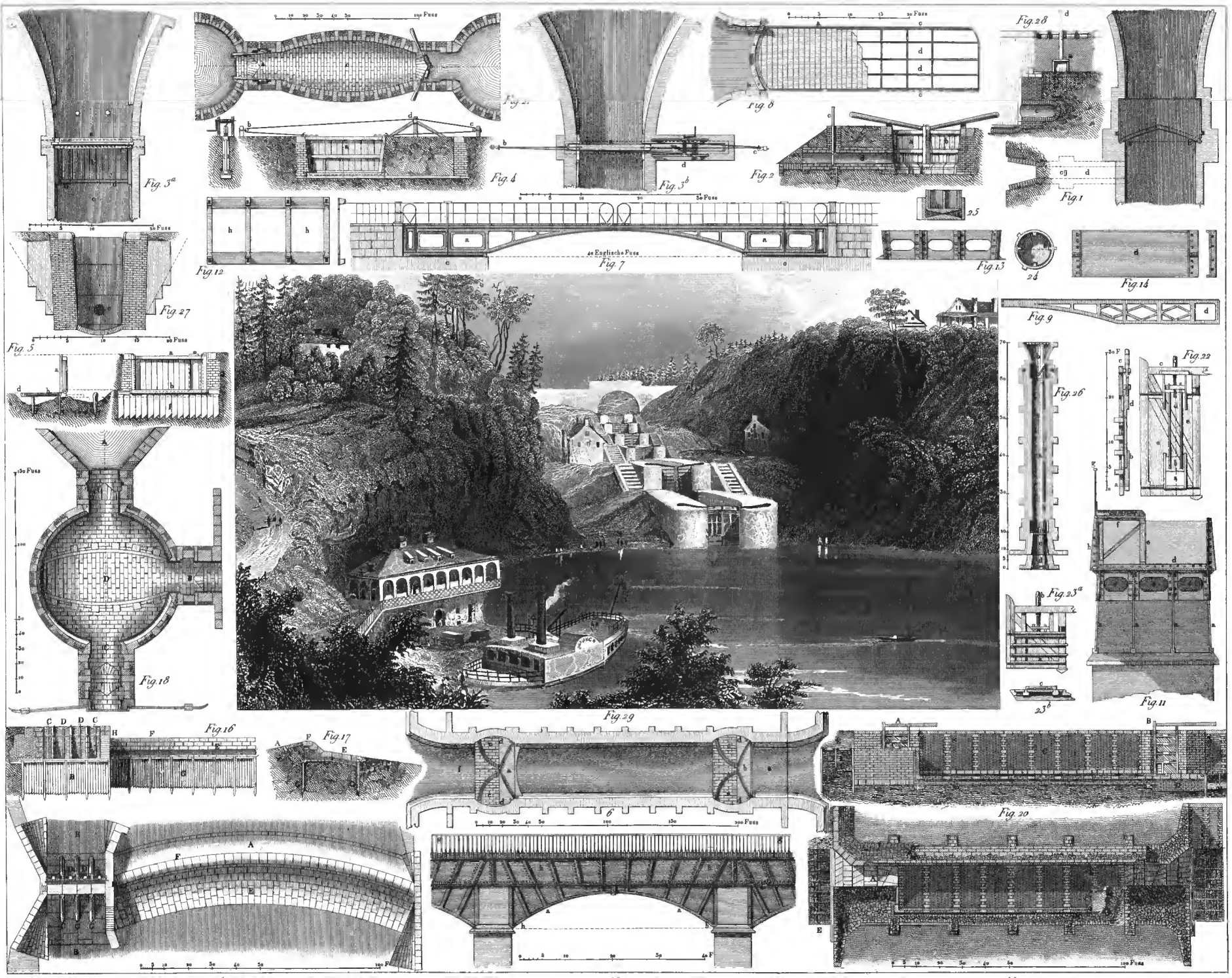
Fig. 30

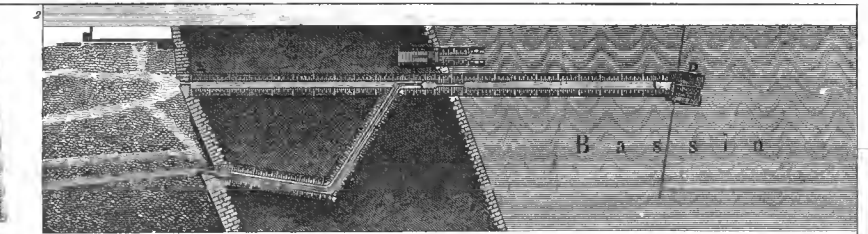
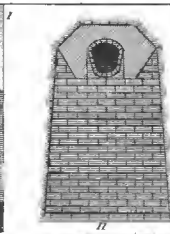
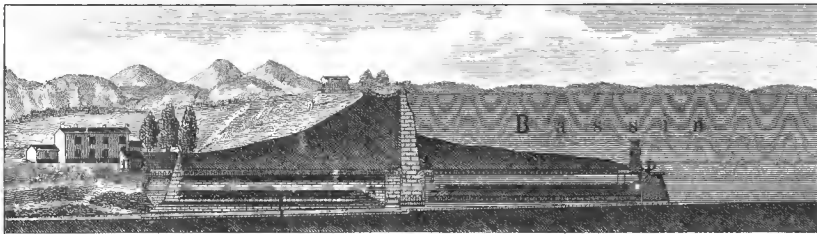




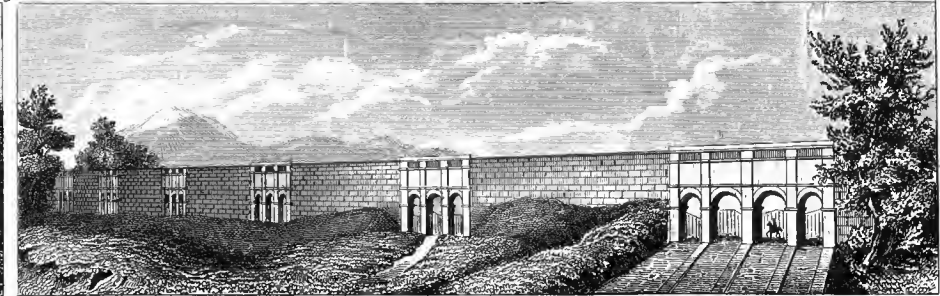
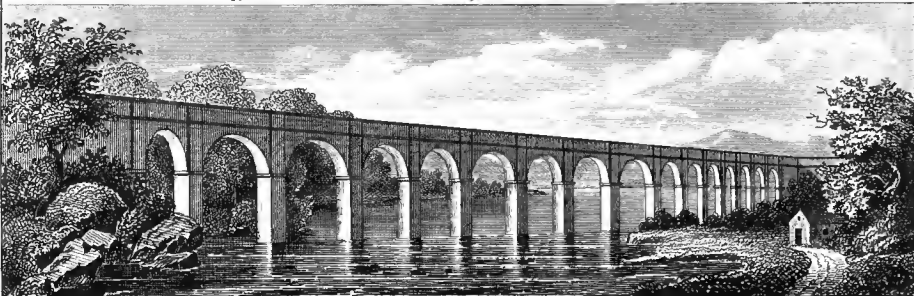
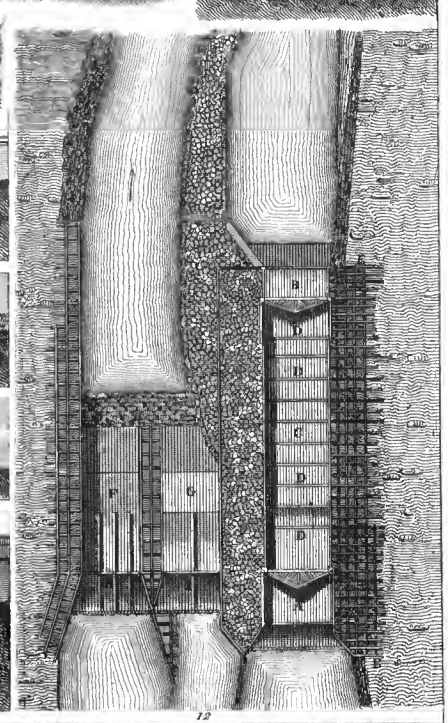
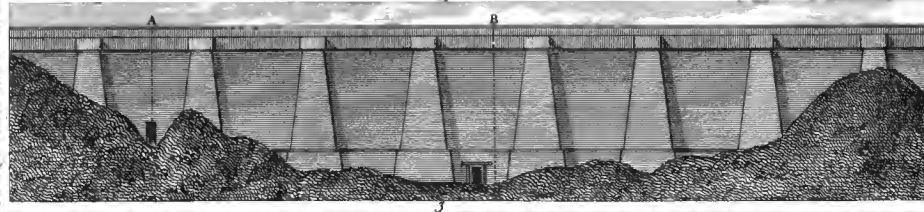
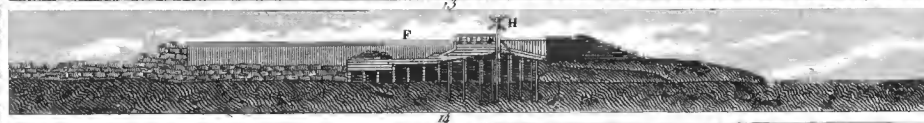
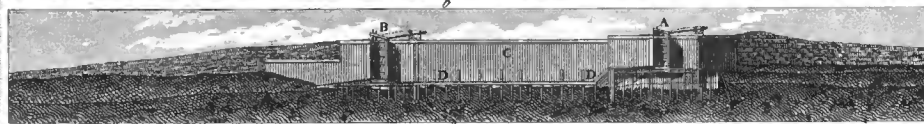
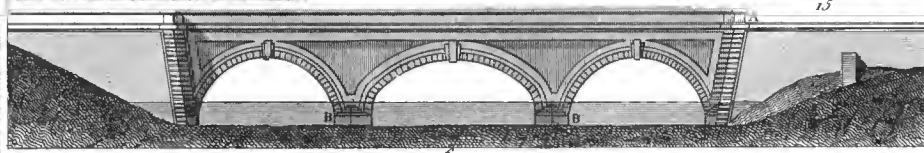
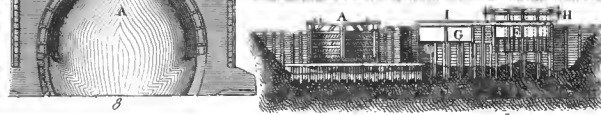
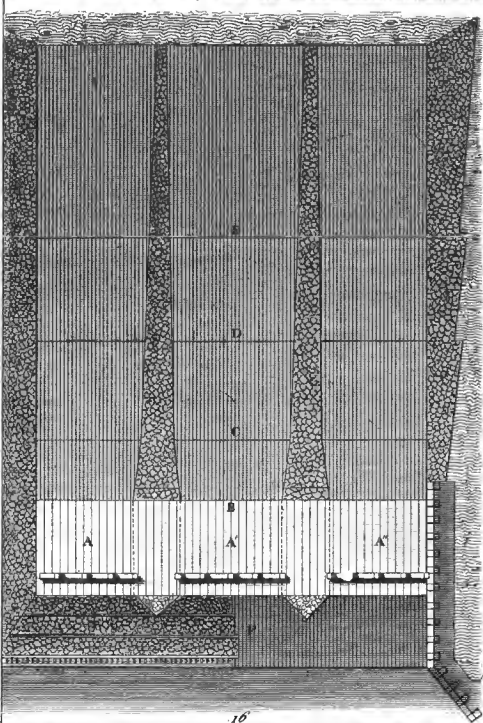
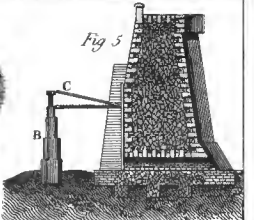
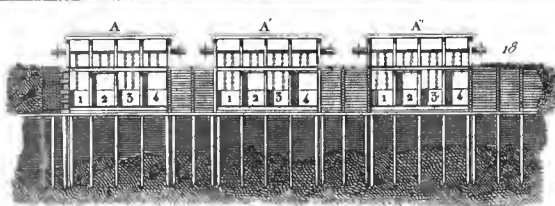
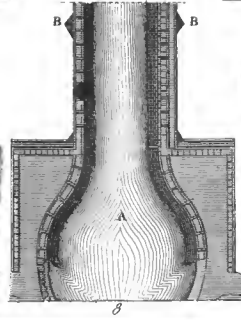
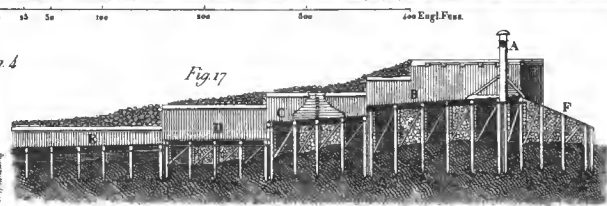
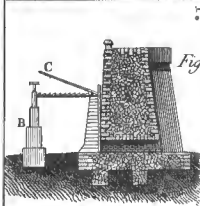








0 15 50 100 500 200 Engl. Fuss.



Maasstab für Figur 13 bis 15.

Maasstab für Figur 3, 4 u. 5.

Maasstab für Figur 16, 17 u. 18.

Feldweg sculp.

0 10 20 30 40 50 60 70 80 90 100 150 Fuss.

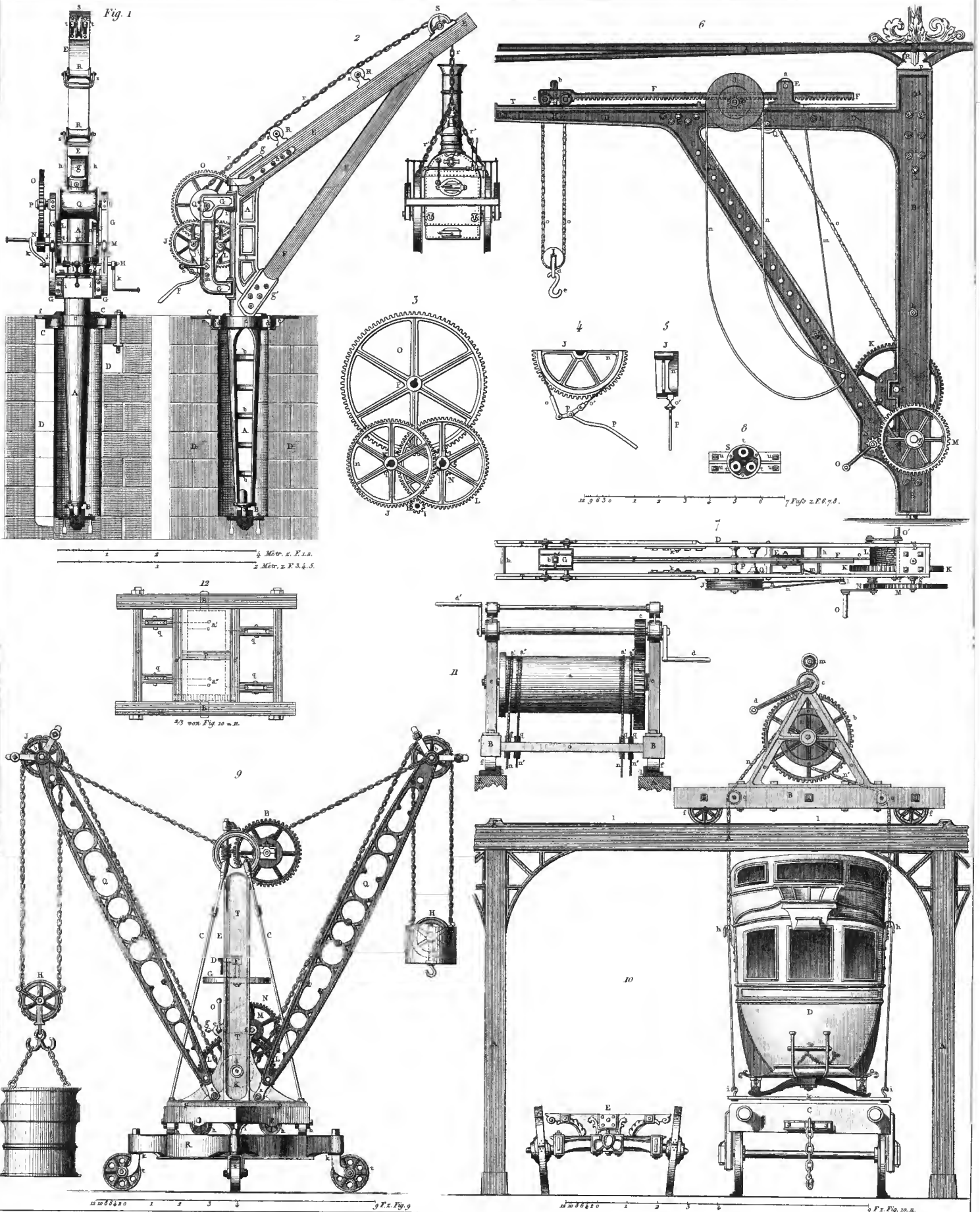


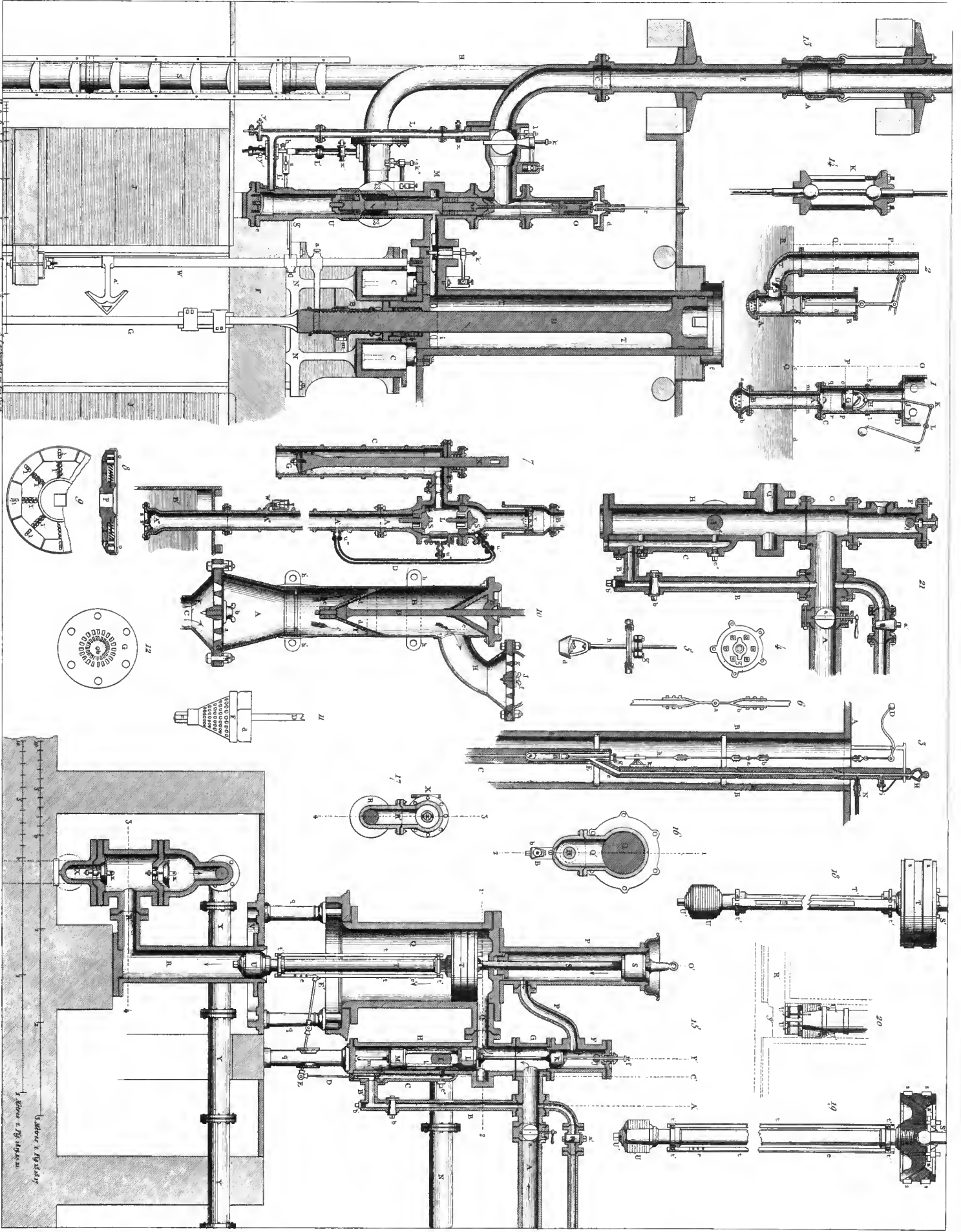
Fig. 1

1/2 Meter = 1 P. L. S.
2 Meter = P. S. 4. S.

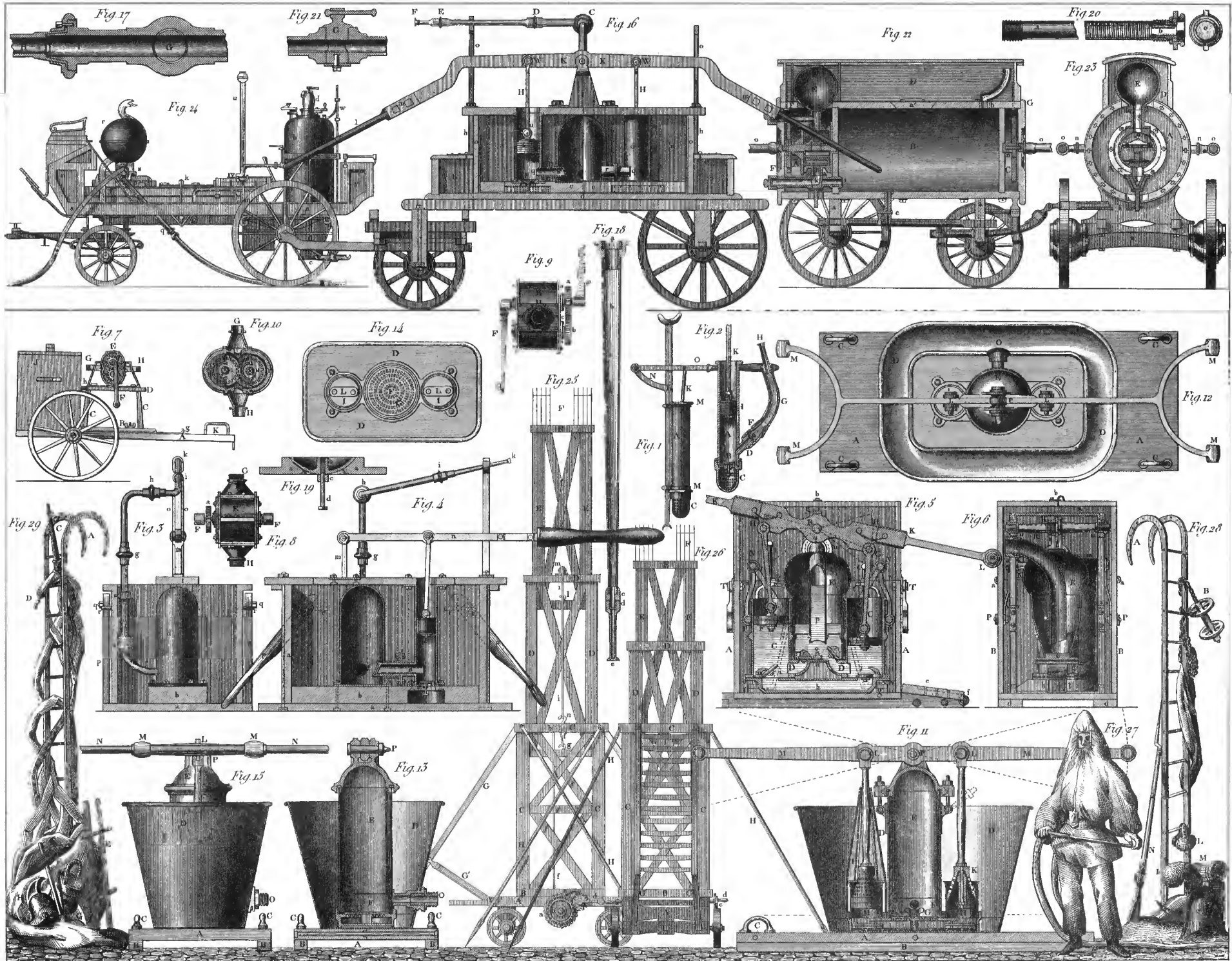
2/3 von Fig. 10 u. n.

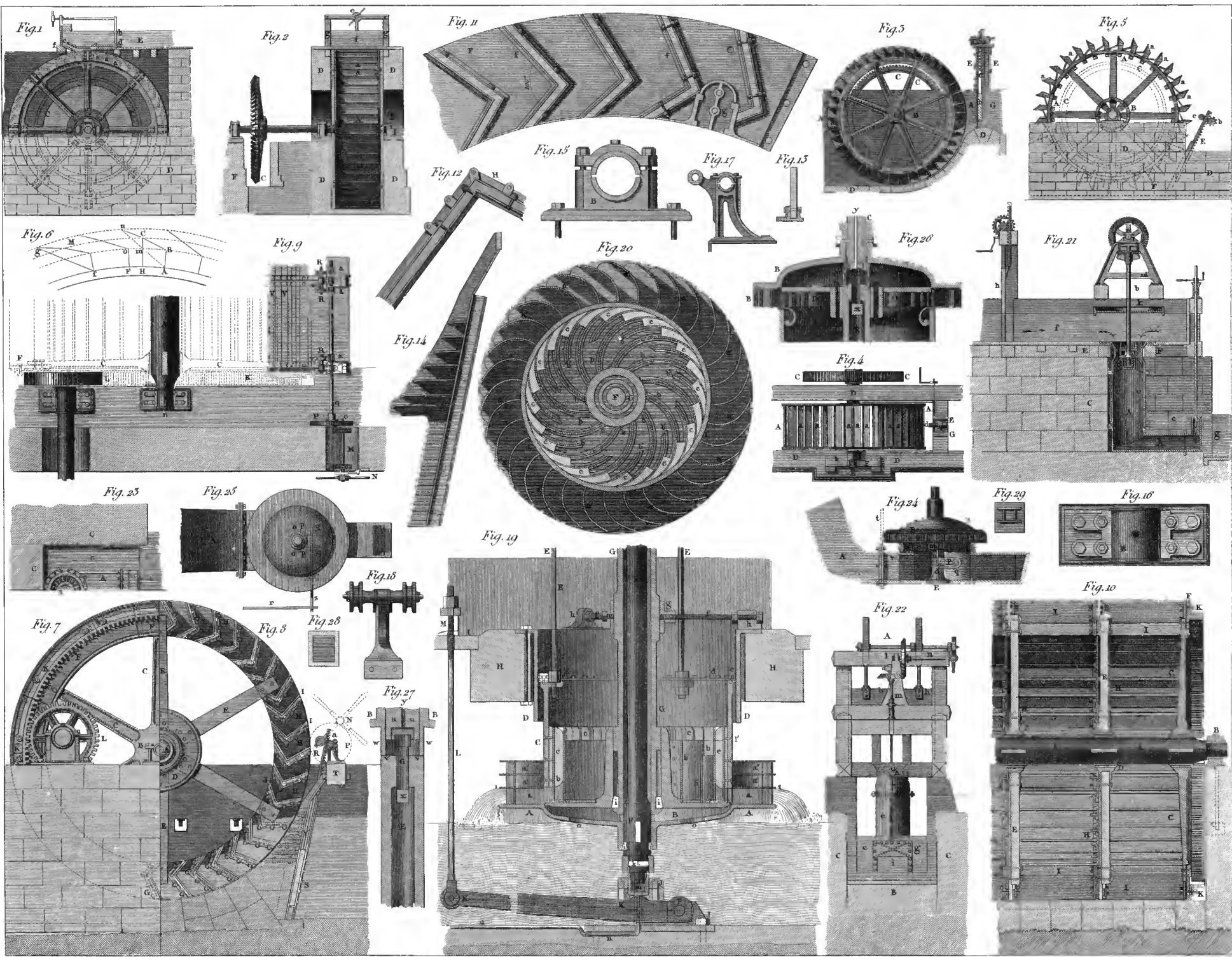
1/2 Meter = 1 P. L. S.
2 Meter = P. S. 4. S.

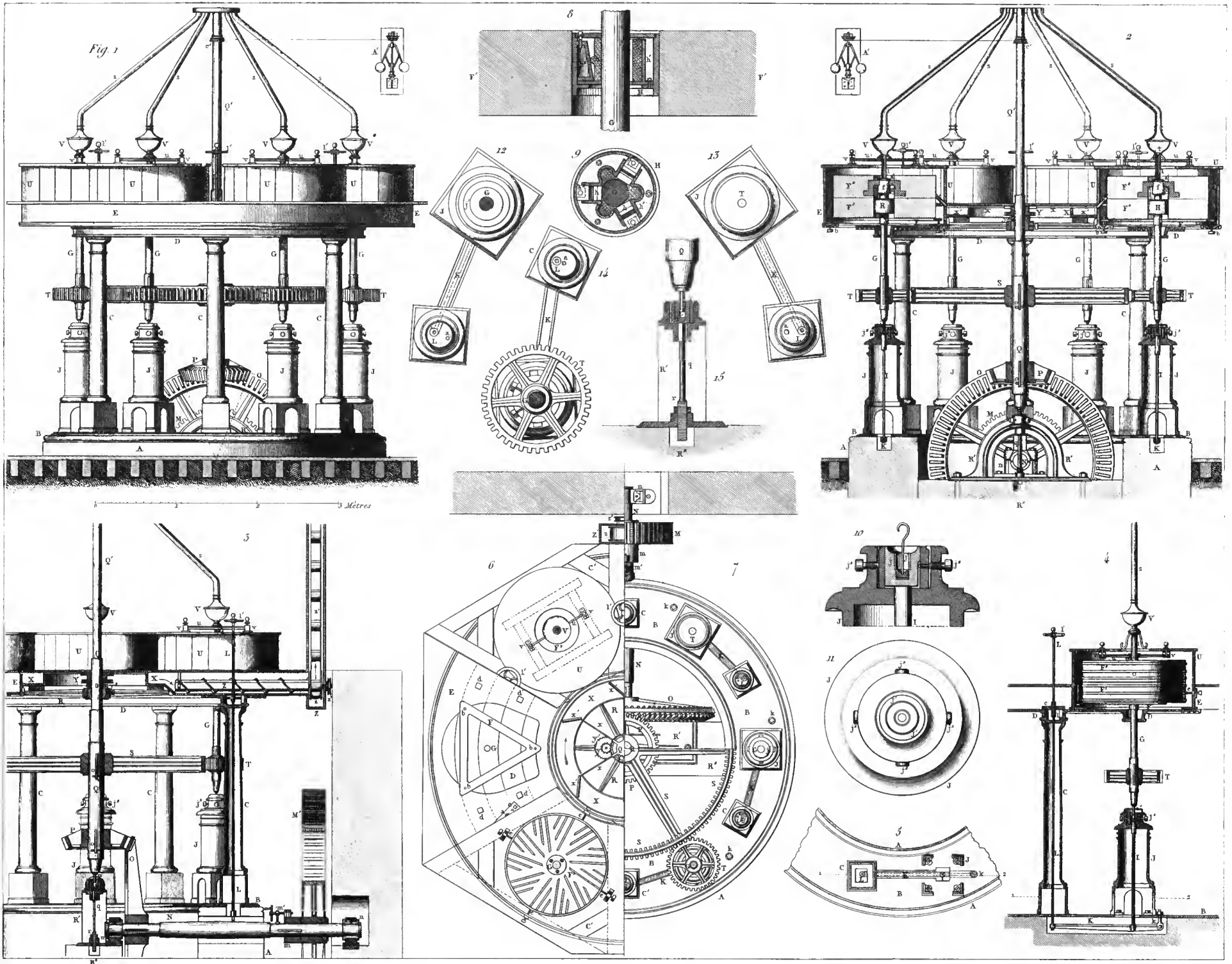
1/2 Meter = 1 P. L. S.
2 Meter = P. S. 4. S.

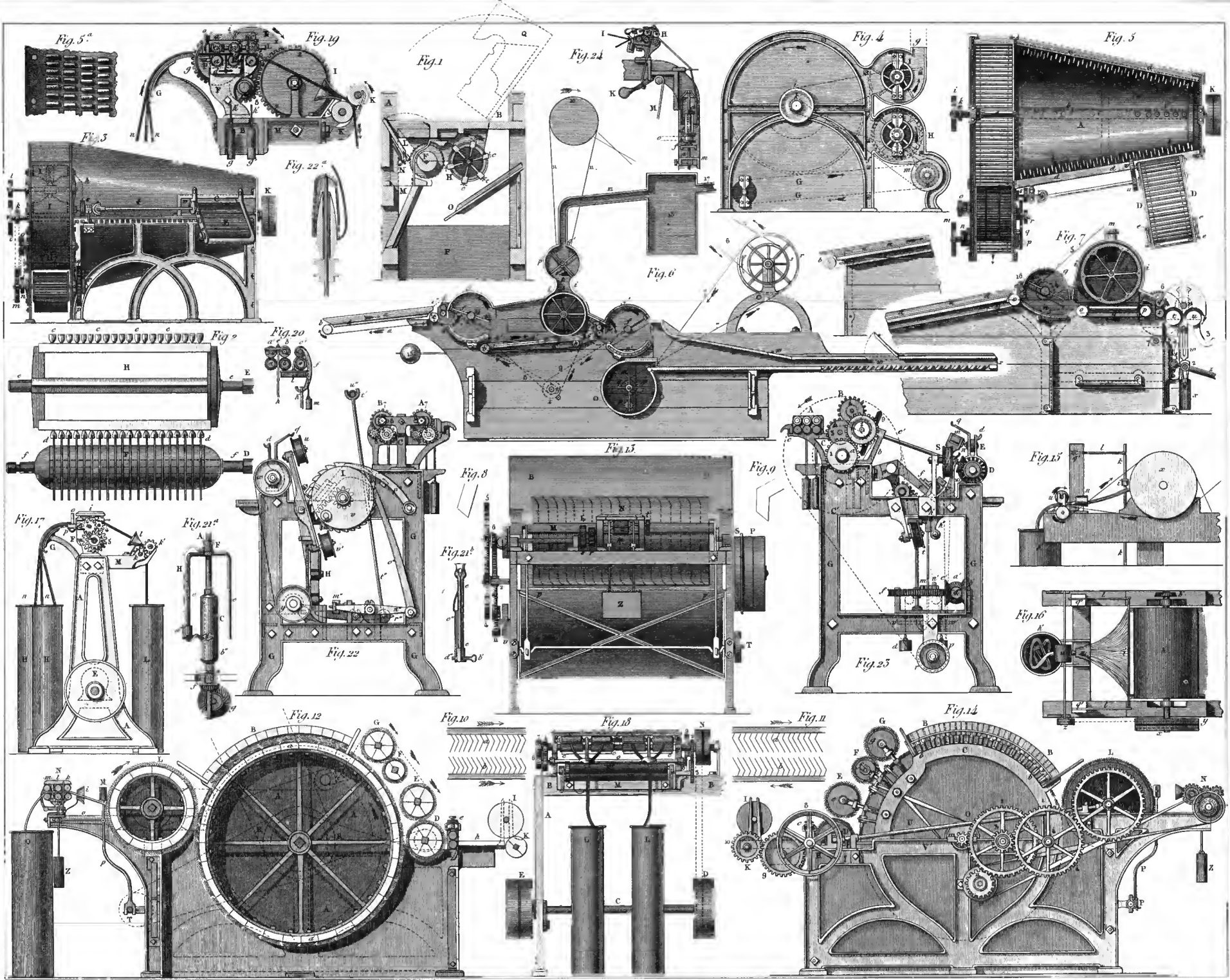


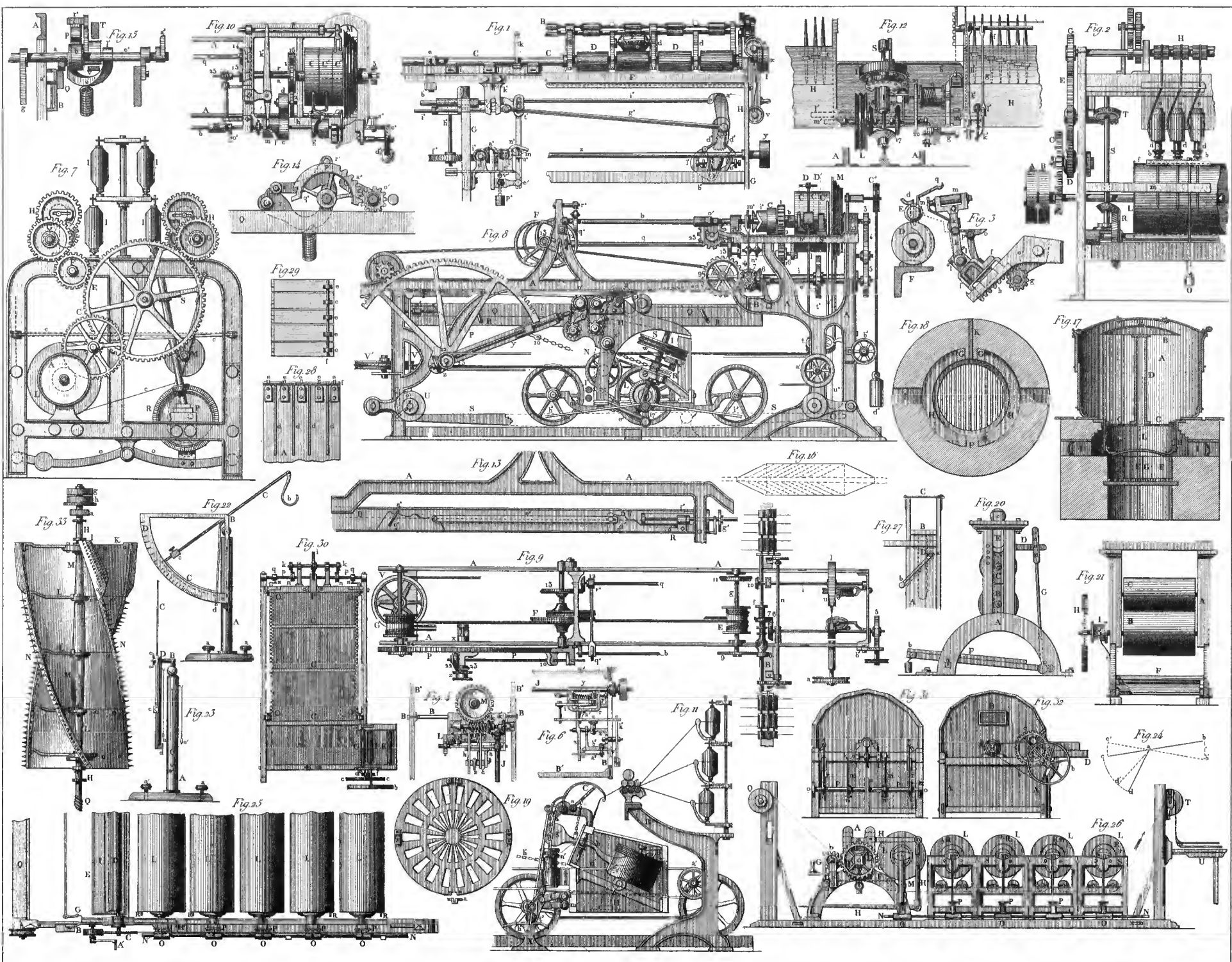
U. S. Patent Office
 1880
 1881
 1882
 1883
 1884
 1885
 1886
 1887
 1888
 1889
 1890
 1891
 1892
 1893
 1894
 1895
 1896
 1897
 1898
 1899
 1900

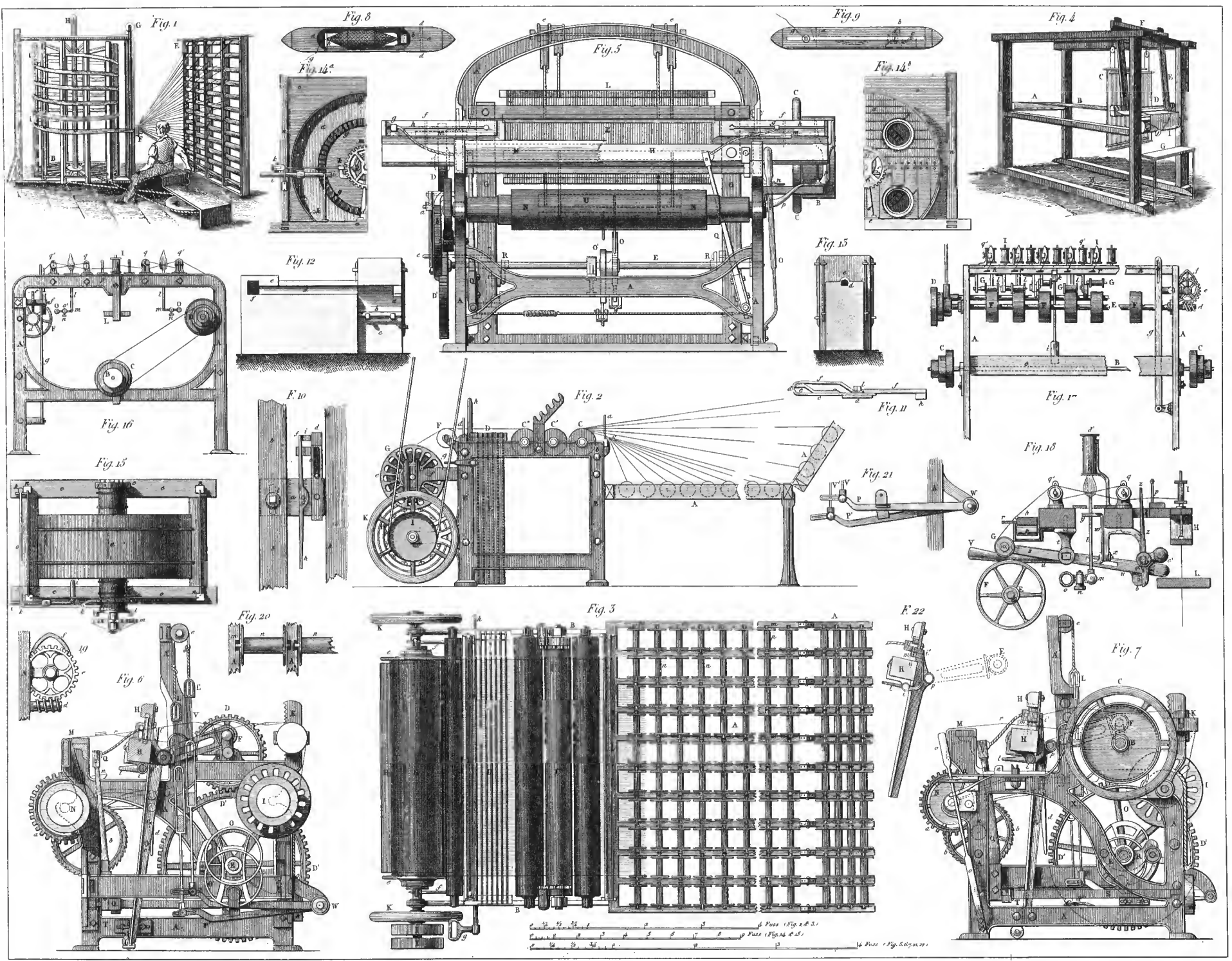


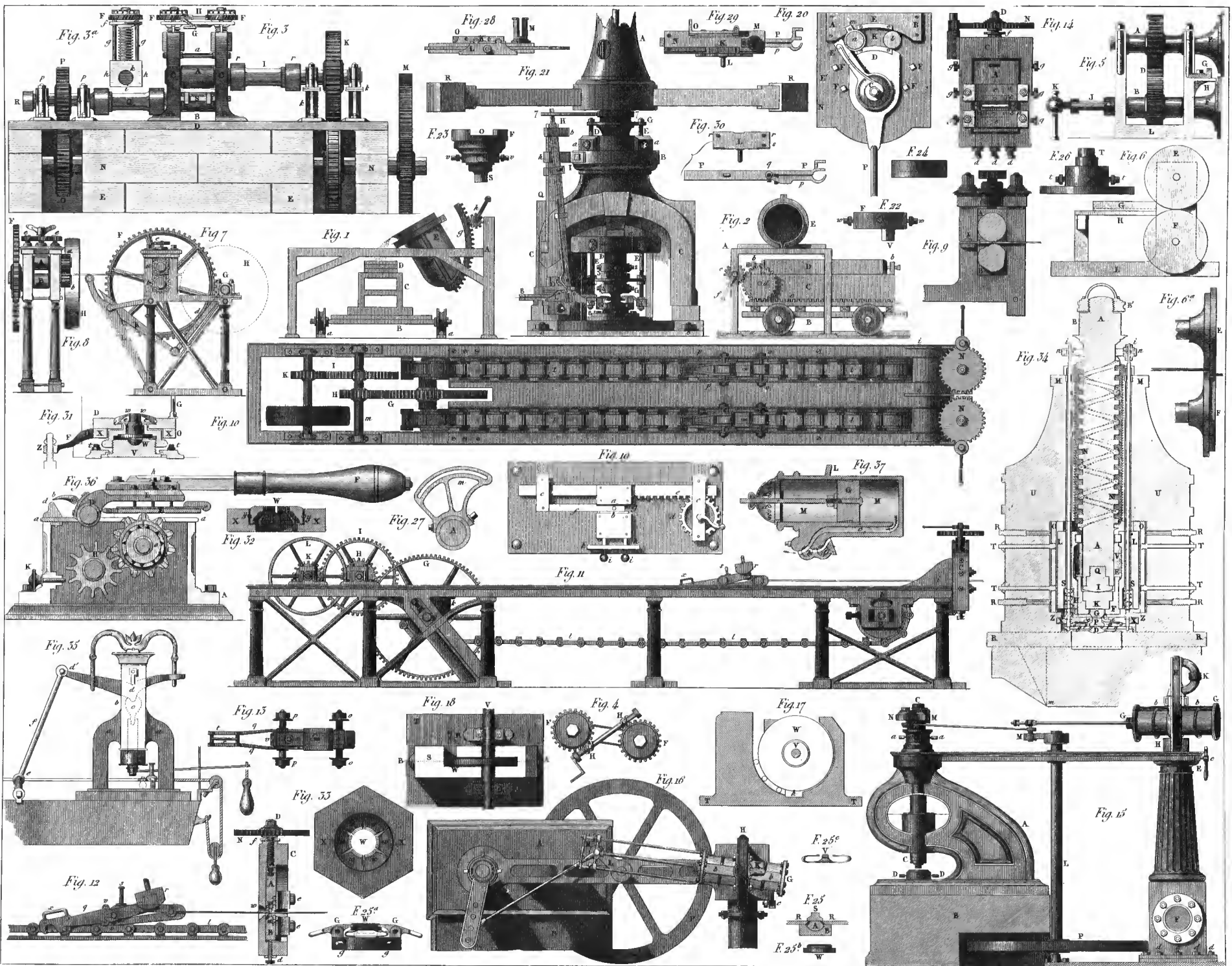












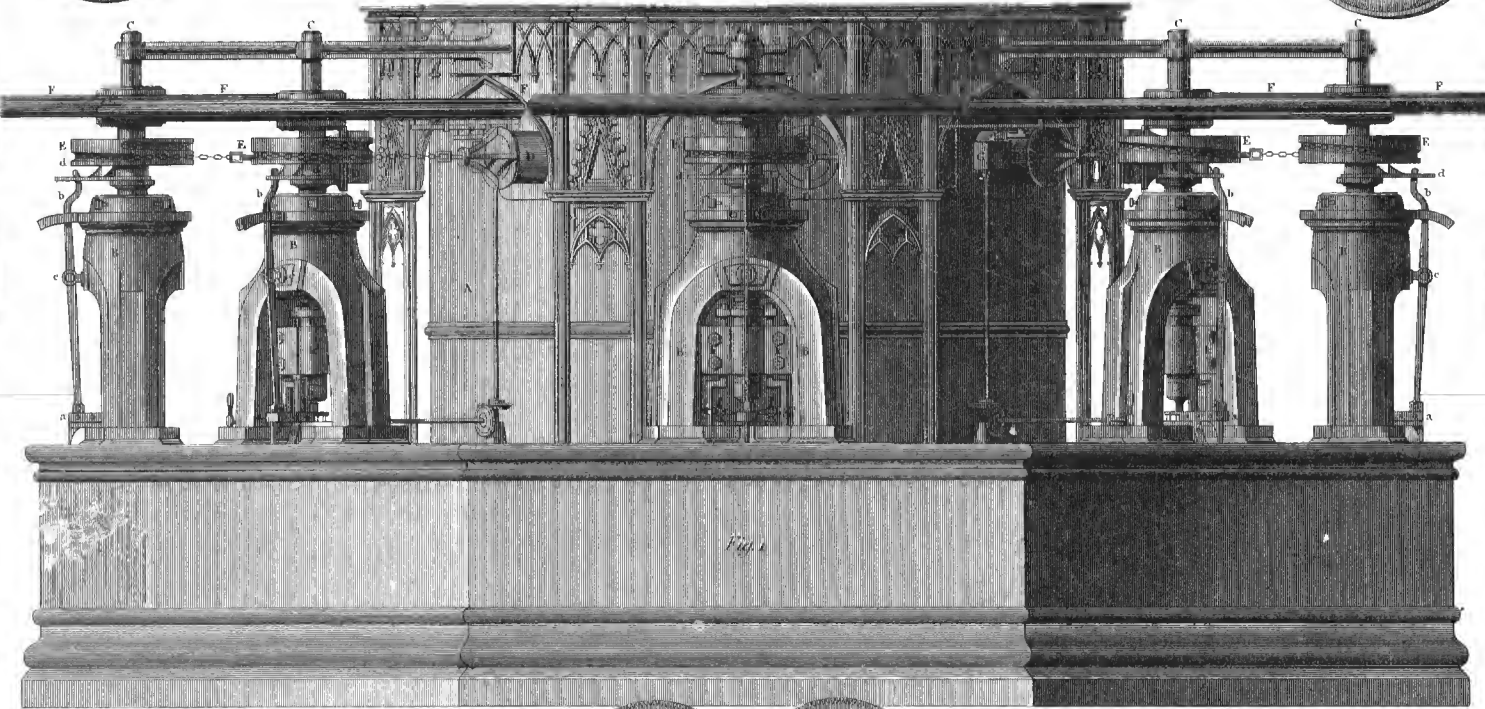


Fig. 11

Fig. 12

Fig. 1

Fig. 13

Fig. 15

Fig. 21

Fig. 19



